

# **TENDER DOCUMENT NO. T-362(R)-2026**

## **PROCUREMENT OF UNIFORM ITEMS WITH ACCESSORIES/ LIVERIES FOR KEY POINT INSTALLATION (PHASE-I)**

**(Single Stage Two Envelope Procedure)**

**(National Competitive Bidding)**



PREPARED BY:  
O/O CHIEF ENGINEER (AM) NORTH (NGC)  
NTDC HOUSE, LAHORE, PAKISTAN

**NATIONAL GRID COMPANY (NGC) OF  
PAKISTAN**

**April, 2026**

**BIDDING DOCUMENTS  
FOR  
CONTRACT NO. T-362(R)-2026**

---

**PROCUREMENT OF UNIFORM ITEMS WITH ACCESSORIES/  
LIVERIES FOR KEY POINT INSTALLATION (PHASE-I)**

**TABLE OF CONTENTS**

**SECTION I:** Invitation for bids

**SECTION II:** Instruction to bidders (ITB).....ITB-1 to ITB-40

**SECTION III:** Bid Data Sheet (BDS)..... BDS-1 to BDS-25

**SECTION IV:** Eligible Countries..... EC-1

**SECTION V:** Schedule of Requirements, Technical Specifications.....SP-1 to SP-15

**SECTION VI:** Standard Forms .....SF-1 to SF-46

**SECTION VII:** General Conditions of the Contract..... GCC-1 to GCC-15

**SECTION VIII:** Special Conditions of The Contract (SCC).....SCC-1 to SCC-18

**SECTION IX:** Bill of Quantities..... B-1 to B-2

**SECTION X:** Contract Forms ..... CF-1 to CF-8

# **VOLUME-I**

**PART-A**  
**BIDDING PROCEDURE & REQUIREMENTS**

## **SECTION I: INVITATION FOR BIDS**



# National Grid Company of Pakistan Limited (NGC)

(Formerly NTDC)

Ref No. CE/AMN/P&S/T-362(R)-2026/\_\_\_\_\_

Date: \_\_\_\_/04/2026

**Asset Management North**

**Chief Engineer (AM) North Lahore**

## **INVITATION FOR BID**

1. National Grid Company (NGC) of Pakistan (formerly NTDC), "The Purchaser", is responsible for development and control of power transmission system in the country, invites electronic bids on E-PADS v2.0 for execution of below mentioned supply works through "Single Stage Two Envelope Procedure" (SSTE) on National Competitive Bidding (NCB) basis from eligible firms registered with Income Tax and Sales Tax Departments and who are on Active Tax payers List of the Federal Board of Revenue (detailed terms & conditions, types and quantities mentioned in the bidding document).

<b>Tender No.</b>	<b>NAME OF WORK</b>
<b>T-362(R)-2026</b>	Procurement of Uniform Items with Accessories/ Liveries for Key Point Installation (Phase-I)

2. Bidding Documents, containing detailed terms and conditions, etc. can be accessed through E-PAK Acquisition and Disposal System (E-PADS v2.0) at ([www.epads.gov.pk](http://www.epads.gov.pk)). Interested eligible bidders are requested to register themselves on E-PADS v2.0 and submit their bid on E-PADS before the date & time of submission of Bids. Manual bids shall not be accepted, in any case.
3. This advertisement is also available on PPRA and NGC websites ([www.ppra.org.pk](http://www.ppra.org.pk) & [www.ntdc.com.pk](http://www.ntdc.com.pk)). All eligible bidders need to prepare their bids according to the instructions given in Bidding Document and submit their bids electronically through E-PAK Acquisition and Disposal System (E-PADS v2.0) up to 18.05.2026 at 11:00 hrs. The bids will be opened on the same day at 11:30 hrs through E-PADS in the office of Chief Engineer (AM) North, NGC Lahore at below mentioned address.  
**Chief Engineer (AM) North NGC,  
34, Industrial Area, Gulberg-III, Lahore  
Telephone: 042-99263023**
4. Samples of all BoQ items must be provided to above mentioned office before the date & time of bid submission on E-PADS. Non-submission of samples may result in rejection of bids.
5. All Bids must be accompanied by a Bid Security in favor of "Chief Engineer (AM) North, NTDC Lahore", equal to an amount mentioned in bidding document, in the form of CDR/ Banker's Cheque or Pay Order from a Bank in Pakistan. The Bid Security must be submitted in original to above-mentioned office on or before the date and time of submission of bids on E-PADS.
6. The NGC reserves the right to reject all bids and to annul bidding process at any stage prior to contract award as defined in Clause 33(1) of Public Procurement Rules 2004.
6. The bidder should not be blacklisted from NGC, DISCO or any Government organization at the time of bidding.

**Chief Engineer (AM) North NGC,  
NTDC House Lahore.**

**C.C.**

1. General Manager (AM) North NGC, WAPDA House, Lahore.
2. Director (Media & Public Relations) NGC G-63, WAPDA House Lahore for publication in the leading newspapers as per Government policy.
3. Director (I.T) NGC, WAPDA House, Lahore with the request to upload the above tender notice on NGC website, please.
4. Dy. Manager (C/A) AM North NGC Lahore.

## **SECTION II: INSTRUCTIONS TO BIDDERS**

### A. INTRODUCTION

<b>1. Scope of Bid</b>	<b>1.1</b>	The Procuring Agency (PA), as indicated in the <b>Bid Data Sheet (BDS)</b> invites Bids for the provision of Goods as specified in the BDS and <b>Section V - Technical Specifications &amp; Schedule of Requirements</b> . The successful Bidders will be expected to deliver the goods within the specified period and timeline(s) as stated in the <b>BDS</b> .
<b>2. Source of Funds</b>	<b>2.1</b>	Source of funds will be arranged on NGC Own Resources.
<b>3. Eligible Bidders</b>	<b>3.1</b>	A Bidder may be natural person, company or firm or public or semi-public agency of Pakistan or any foreign country, or any combination of them with a formal existing agreement (on Judicial Papers) in the form of a joint venture, consortium, or association. In the case of a joint venture, consortium, or association, all members shall be jointly and severally liable for the execution of the Contract in accordance with the terms and conditions of the Contract. The joint venture, consortium, or association shall nominate a Lead Member as nominated in the BDS, who shall have the authority to conduct all business for and on behalf of any and all the members of the joint venture, consortium, or association during the Bidding process, and in case of award of contract, during the execution of contract. <i>(The limit on the number of members of JV or Consortium or Association may be prescribed in BDS, in accordance with the guidelines issued by the PPRA).</i>
	<b>3.2</b>	The appointment of Lead Member in the joint venture, consortium, or association shall be confirmed by submission of a valid Power of Attorney to the Procuring Agency.
	<b>3.3</b>	Verifiable copy of the agreement that forms a joint venture, consortium or association shall be required to be submitted as part of the Bid.
	<b>3.4</b>	Any bid submitted by the joint venture, consortium or association shall indicate the part of proposed contract to be performed by each party and each party shall be evaluated (or post qualified if required) with respect to its contribution only, and the responsibilities of each party shall not be substantially altered without prior written approval of the Procuring Agency and in line with any instructions issued by the Authority.
	<b>3.5</b>	The invitation for Bids is open to all prospective supplier, manufacturers or authorized agents/dealers subject to any provisions of incorporation or licensing by the respective

		national incorporating agency or statutory body established for that particular trade or business.
	<b>3.6 .</b>	Foreign Bidders must be locally registered with the appropriate national incorporating body or the statutory body, before participating in the national/international competitive tendering with the exception of such procurements made by the foreign missions of Pakistan. For such purpose the bidder must have to initiate the registration process before the bid submission and the necessary evidence shall be submitted to the procuring agency along with their bid, however, the final award will be subject to the complete registration process. (Not Applicable)
	<b>3.7</b>	<p>A Bidder shall not have a conflict of interest. All Bidders found to have a conflict of interest shall be disqualified. A Bidders may be considered to have a conflict of interest with one or more parties in this Bidding process, if they:</p> <ul style="list-style-type: none"> <li>a) are associated or have been associated in the past, directly or indirectly with a firm or any of its affiliates which have been engaged by the Procuring Agency to provide consulting services for the preparation of the design, specifications and other documents to be used for the procurement of the goods to be purchased under this Invitation for Bids.</li> <li>b) have controlling shareholders in common; or</li> <li>c) receive or have received any direct or indirect subsidy from any of them; or</li> <li>d) have the same legal representative for purposes of this Bid; or</li> <li>e) have a relationship with each other, directly or through common third parties, that puts them in a position to have access to information about or influence on the Bid of another Bidder, or influence the decisions of the Procuring Agency regarding this Bidding process; or</li> <li>f) Submit more than one Bid in this Bidding process.</li> </ul>
	<b>3.8</b>	<p>A Bidder may be ineligible if –</p> <ul style="list-style-type: none"> <li>(a) he is declared bankrupt or, in the case of company or firm, insolvent;</li> <li>(b) payments in favor of the Bidder is suspended in accordance with the judgment of a court of law other than a judgment declaring bankruptcy and resulting (in accordance with the national laws) in the total or partial loss of the right to administer and dispose of its property;</li> <li>(c) legal proceedings are instituted against such Bidder involving an order suspending payments and which may</li> </ul>

		<p>result, in accordance with the national laws, in a declaration of bankruptcy or in any other situation entailing the total or partial loss of the right to administer and dispose of the property;</p> <p>(d) the Bidder is convicted, by a final judgment, of any offence involving professional conduct;</p> <p>(e) the Bidder is blacklisted and hence debarred due to involvement in corrupt and fraudulent practices, or performance failure or due to breach of bid securing declaration.</p> <p>(f) The firm, supplier and contractor is blacklisted or debarred by a foreign country, international organization, or other foreign institutions for the period defined by them.</p>
	<b>3.9</b>	Bidders shall provide to the Procuring Agency evidence of their eligibility, proof of compliance with the necessary legal requirements to carry out the contract effectively.
	<b>3.10</b>	Bidders shall provide such evidence of their continued eligibility to the satisfaction of the Procuring Agency, as the Procuring Agency shall reasonably request.
	<b>3.11</b>	Bidders shall submit proposals relating to the nature, conditions and modalities of sub-contracting wherever the sub-contracting of any elements of the contract amounting to the more than ten (10) percent of the Bid price is envisaged.
<b>4. Eligible Goods and Related Services</b>	<b>4.1</b>	All goods and related services to be supplied under the contract shall have their origin in eligible source countries, and all expenditures made under the contract will be limited to such goods and services. For purpose of this Bid, ineligible countries are stated in the section-4 titled as “Eligible Countries”.
	<b>4.2</b>	For purposes of this Clause, “origin” means the place where the goods are mined, grown, cultivated, produced, manufactured, or processed, or through manufacture, procession, or assembly, another commercially recognized article results that differs substantially in its basic characteristics from its imported components or the place from where the related services are/to be supplied.
	<b>4.3</b>	The nationality of the supplier that supplies, assembles, distributes, or sells the goods and services shall not determine the origin of the goods.
	<b>4.4</b>	To establish the eligibility of the Goods and the related services, Bidders shall fill the country of origin declarations included in the Form of Bid.
	<b>4.5</b>	If so required in the <b>BDS</b> , the Bidder shall demonstrate that it has been duly authorized by the manufacturer of the goods to deliver in Pakistan (or in respective country in case of

		procurement by the Pakistani Missions abroad), the goods indicated in its Bid.
<b>5. One Bid per Bidder</b>	<b>5.1</b>	A bidder shall upload only one Bid on E-PADS, in the same bidding process, either individually as a Bidder or as a member in a joint venture or any similar arrangement.
	<b>5.2</b>	No bidder can be a sub-contractor while submitting a Bid individually or as a member of a joint venture in the same Bidding process.
	<b>5.3</b>	A person or a firm cannot be a sub-contractor with more than one bidder in the same bidding process.
<b>6. Cost of Bidding</b>	<b>6.1</b>	The Bidder shall bear all costs associated with the preparation and submission/ uploading of its Bid, and the Procuring Agency shall in no case be responsible or liable for those costs, regardless of the conduct or outcome of the bidding process.

**B. BIDDING DOCUMENTS**

<b>7. Contents of Bidding Documents</b>	<b>7.1</b>	<p>The goods required, bidding procedures, and terms and conditions of the contract are prescribed in the Bidding Documents. In addition to the Invitation to Bids, the Bidding Documents which should be read in conjunction with any addenda issued in accordance with ITB 9.2 include:</p> <p><b>Section I</b> -Invitation for Bids  <b>Section II</b>-Instructions to Bidders (ITBs)  <b>Section III</b>-Bid Data Sheet (BDS)  <b>Section IV</b>-Eligible Countries  <b>Section V</b>- Technical Specifications &amp; Schedule of Requirements.  <b>Section VI</b>- Standard Forms  <b>Section VII</b>-General Conditions of Contract (GCC)  <b>Section VIII</b>-Special Conditions of Contract (SCC)  <b>Section IX</b>-Contract Forms</p>
	<b>7.2</b>	The number of copies to be completed and returned with the Bid is specified in the <b>BDS</b> . (Not Applicable)
	<b>7.3</b>	The Invitation for Bids (Section-I) issued by the Procuring Agency is not part of the Bidding Documents. In case of discrepancies between the Invitation for Bid and the Bidding Documents listed in ITB 7.1 above, said Bidding Documents will take precedence & will be uploaded/ available on E-PADS.
	<b>7.4</b>	The Procuring Agency is not responsible for the completeness of the Bidding Documents and their addenda, if they were not directly downloaded from the Procuring Agency's website/ E-PADS. However, Procuring Agency shall place both the pdf and same editable version to facilitate the bidder for filling the forms.
	<b>7.5</b>	The Bidder is expected to examine all instructions, forms, terms and specifications in the Bidding Documents. Failure to furnish all the information required in the Bidding Documents will be at the Bidder's risk and may result in the rejection of his Bid.
<b>8. Clarification of Bidding Documents</b>	<b>8.1</b>	A prospective Bidder requiring any clarification of the Bidding Documents may notify the Procuring Agency in writing or in electronic form that provides record of the content of communication at the Procuring Agency's address indicated in the <b>BDS</b> .
	<b>8.2</b>	The Procuring Agency will within three (3) working days after receiving the request for clarification, respond in writing or in electronic form to any request for clarification provided that such request is received not later than three (03) days prior to the deadline for the submission of Bids as prescribed in <b>ITB</b>

		<b>23.1.</b> However, this clause shall not apply in case of alternate methods of Procurement.
	<b>8.3</b>	Copies of the Procuring Agency's response will be forwarded to all identified Prospective Bidders through an identified source of communication, including a description of the inquiry, but without identifying its source. In case of downloading of the Bidding Documents from the website of PA, the response of all such queries will also be available on the same link available at the website.
	<b>8.4</b>	Should the Procuring Agency deem it necessary to amend the Bidding Documents as a result of a clarification, it shall do so following the procedure under <b>ITB 9</b> .
	<b>8.5</b>	If indicated <b>in the BDS</b> , the Bidder's designated representative is invited at the Bidder's cost to attend a pre-Bid meeting at the place, date and time mentioned <b>in the BDS</b> . During this pre-Bid meeting, prospective Bidders may request clarification of the schedule of requirement, the Evaluation Criteria or any other aspects of the Bidding Documents.
	<b>8.6</b>	Minutes of the pre-Bid meeting, if applicable, including the text of the questions asked by Bidders, including those during the meeting (without identifying the source) and the responses given, together with any responses prepared after the meeting will be transmitted promptly to all prospective Bidders who have obtained the Bidding Documents. Any modification to the Bidding Documents that may become necessary as a result of the pre-Bid meeting shall be made by the Procuring Agency exclusively through the use of an Addendum pursuant to ITB 9. Non-attendance at the pre-Bid meeting will not be a cause for disqualification of a Bidder.
<b>9. Amendment of Bidding Documents</b>	<b>9.1</b>	Before the deadline for submission of Bids, the Procuring Agency for any reason, whether at its own initiative or in response to a clarification requested by a prospective Bidder or pre-Bid meeting may modify the Bidding Documents by issuing addenda.
	<b>9.2</b>	Any addendum issued including the notice of any extension of the deadline shall be part of the Bidding Documents pursuant to <b>ITB 7.1</b> and shall be communicated in writing or in any identified electronic form that provide record of the content of communication to all the bidders who have obtained the Bidding Documents from the Procuring Agency. The Procuring Agency shall promptly publish the Addendum at the Procuring Agency's web page identified in the BDS: Provided that the bidder who had either already submitted their bid on E-PADS prior to the issuance of any such addendum shall

		have the right to withdraw his already filed bid and submit the revised bid through E-PADS prior to the original or extended bid submission deadline. (As per provision of E-PADS)
	<b>9.3</b>	To give prospective Bidders reasonable time in which to take an addendum/corrigendum into account in preparing their Bids, the Procuring Agency may, at its discretion, extend the deadline for the submission of Bids:  Provided that the Procuring Agency shall extend the deadline for submission of Bid, if such an addendum is issued within last three (03) days of the Bid submission deadline.

### C. PREPARATION OF BIDS

<b>10. Language of Bid</b>	<b>10.1</b>	The Bid prepared by the Bidder, as well as all correspondence and documents relating to the Bid exchanged by the Bidder and the Procuring Agency shall be written in the English language unless specified in the <b>BDS</b> . Supporting documents and printed literature furnished by the Bidder may be in another language provided they are accompanied by an accurate translation of the relevant pages in the English language unless specified in the <b>BDS</b> , in which case, for purposes of interpretation of the Bidder, the translation shall govern.
<b>11. Documents and Sample(s) Constituting the Bid</b>	<b>11.1</b>	The Bid prepared by the Bidder shall constitute the following components: -  a) Form of Technical & Financial Bids and Bid Prices completed in accordance with ITB 14 and 15; b) Details of the Sample(s) where applicable and requested in the BDS. c) Documentary evidence established in accordance with ITB 13 that the Bidder is eligible and/or qualified for the subject bidding process; d) Documentary evidence established in accordance with ITB 13.3(a) that the Bidder has been authorized by the manufacturer to deliver the goods into Pakistan, where required and where the supplier is not the manufacturer of those goods; e) Documentary evidence established in accordance with ITB 12 that the goods and related services to be supplied by the Bidder are eligible goods and services, and conform to the Bidding Documents; f) Bid security or Bid Securing Declaration furnished in accordance with ITB 18;

		<p>g) Duly Notarized Power of Attorney authorizing the signatory of the Bidder to submit the bid; and</p> <p>h) Any other document required in the BDS.</p>
	<b>11.2</b>	<p>Where a sample(s) is required by a procuring agency, the sample shall be:</p> <p>(a) submitted as part of the bid, in the quantities, dimensions and other details requested in the <b>BDS</b>;</p> <p>(b) carriage paid;</p> <p>(c) received on, or before, the closing time and date for the submission of bids on E-PADS; and</p> <p>(d) evaluated to determine compliance with all characteristics listed in the <b>BDS</b>.</p>
	<b>11.3</b>	<p>The Procuring Agency shall retain the sample(s) of the successful Bidder. A Procuring Agency shall reject the Bid if the sample(s)-</p> <p>(a) do(es) not conform to all characteristics prescribed in the bidding documents; and</p> <p>(b) is/are not submitted within the specified time clearly mentioned in the Bid Data Sheet.</p>
	<b>11.4</b>	<p>Where it is not possible to avoid using a propriety article as a sample, a Bidder shall make it clear that the propriety article is displayed only as an example of the type or quality of the goods being Bided for, and that competition shall not thereby be limited to the extent of that article only.</p>
	<b>11.5</b>	<p>Samples made up from materials supplied by a Procuring Agency shall not be returned to a Bidder nor shall a Procuring Agency be liable for the cost of making them.</p>
	<b>11.6</b>	<p>All samples produced from materials belonging to an unsuccessful Bidder shall be kept by the Procuring Agency till thirty (30) days from the date of award of contract or exhaust of all the grievance forums (including those pending at Authority's Level or in some Court of Law).</p>
<b>12. Documents Establishing Eligibility of Goods and Related Services and Conformity to Bidding Documents</b>	<b>12.1</b>	<p>Pursuant to ITB 11, the Bidder shall furnish, as part of its Bid, all those documents establishing the eligibility in conformity to the terms and conditions specified in the Bidding Documents for all goods and related services which the Bidder proposes to deliver.</p>
	<b>12.2</b>	<p>The documentary evidence of the eligibility of the goods and related services shall consist of a statement in the Price Schedule of the country of origin of the goods and related services offered which shall be confirmed by a certificate of origin issued at the time of shipment.</p>

	<b>12.3</b>	<p>The documentary evidence of conformity of the goods and related services to the Bidding Documents may be in the form of literature, drawings, and data, and shall consist of:</p> <ul style="list-style-type: none"> <li>a) a detailed description of the essential technical specifications and performance characteristics of the Goods;</li> <li>b) an item-by-item commentary on the Procuring Agency’s Technical Specifications demonstrating substantial responsiveness of the Goods and Services to those specifications, or a statement of deviations and exceptions to the provisions of the Technical Specifications;</li> <li>c) any other procurement specific documentation requirement as stated in the <b>BDS</b>.</li> </ul>
	<b>12.4</b>	<p>The Bidder shall also furnish a list giving full particulars, including available sources and current prices of goods, spare parts, special tools, etc., necessary for the proper and continuing functioning of the Goods during the period <b>specified in the BDS</b> following commencement of the use of the goods by the Procuring Agency.</p>
	<b>12.5</b>	<p>For purposes of the commentary to be furnished pursuant to <b>ITB 12.3(c)</b> above, the Bidder shall note that standards for workmanship, material, and equipment, as well as references to brand names or catalogue numbers designated by the Procuring Agency in its Technical Specifications, are intended to be descriptive only and not restrictive. The Bidder may substitute alternative standards, brand names, and/or catalogue numbers in its Bid, provided that it demonstrates to the Procuring Agency’s satisfaction that the substitutions ensure substantial equivalence to those designated in the Technical Specifications.</p>
	<b>12.6</b>	<p>The required documents and other accompanying documents must be in English. In case any other language than English is used the pertinent translation into English shall be attached to the original version.</p>
<b>13. Documents Establishing Eligibility and Qualification of the Bidder</b>	<b>13.1</b>	<p>Pursuant to ITB 11, the Bidder shall furnish, as part of its Bid, all those documents establishing the Bidder’s eligibility to participate in the bidding process and/or its qualification to perform the contract if its Bid is accepted.</p>
	<b>13.2</b>	<p>The documentary evidence of the Bidder’s eligibility to Bid shall establish to the satisfaction of the <b>Procuring Agency</b> that the Bidder, at the time of submission of its bid, is from an eligible country as defined in Section-4 titled as “Eligible Countries”.</p>

	<b>13.3</b>	<p>The documentary evidence of the Bidder's qualifications to perform the contract if its Bid is accepted shall establish to the satisfaction of Procuring Agency that:</p> <p>a) in the case of a Bidder offering to deliver goods under the contract which the Bidder did not manufacture or otherwise produce, the Bidder has been duly authorized by the goods' Manufacturer or producer to deliver the goods in Pakistan;</p> <p>b) the Bidder has the financial, technical, and supply/production capability necessary to perform the Contract, meets the qualification criteria specified in BDS.</p> <p>c) in the case of a Bidder not doing business within Pakistan, the Bidder is or will be (if awarded the contract) represented by an Agent in Pakistan equipped, and able to carry out the Supplier's maintenance, repair, and spare parts-stocking obligations prescribed in the Conditions of Contract and/or Technical Specifications.</p> <p>d) that the Bidder meets the qualification criteria listed in the Bid Data Sheet.</p>
<b>14. Form of Bid</b>	<b>14.1</b>	<b>The Bidder shall fill the Form of Bid furnished in the Bidding Documents.</b> The Bid Form must be completed without any alterations to its format and no substitute shall be accepted.
<b>15. Bid Prices</b>	<b>15.1</b>	The Bid Prices and discounts quoted by the Bidder in the Form of Bid and in the Price Schedules shall conform to the requirements specified below in ITB Clause 15 or exclusively mentioned hereafter in the bidding documents.
	<b>15.2</b>	All items in the Statement of Work must be listed and priced separately in the Price Schedule(s). If a Price Schedule shows items listed but not priced, their prices shall be construed to be included in the prices of other items.
	<b>15.3</b>	<p>Items not listed in the Price Schedule shall be assumed not to be included in the Bid, and provided that the Bid is still substantially responsive in their absence or due to their nominal nature, the corresponding average price of the respective item(s) of the remaining substantially responsive bidder(s) shall be construed to be the price of those missing item(s):</p> <p>Provided that:</p> <p>a) where there is only one (substantially) responsive bidder, or</p> <p>b) where there is provision for alternate proposals and the respective items are not listed in the other bids,</p> <p>the procuring agency may fix the price of missing items in accordance with market survey, and the same shall be considered as final price.</p>

	<b>15.4</b>	The Bid price to be quoted in the Form of Bid in accordance with <b>ITB 15.1</b> shall be the total price of the Bid, excluding any discounts offered.
	<b>15.5</b>	The Bidder shall indicate on the appropriate Price Schedule, the unit prices (where applicable) and total Bid price of the goods it proposes to deliver under the contract.
	<b>15.6</b>	<p>Prices indicated on the Price Schedule shall be entered separately in the following manner: (Not Applicable)</p> <p>a) For goods manufactured from within Pakistan (or within the country where procurement is being done in case of foreign missions abroad):</p> <p>i) the price of the goods quoted EXW (ex-works, ex-factory, ex-warehouse, ex-showroom, or off-the-shelf, as applicable), including all customs duties and sales and other taxes already paid or payable:</p> <p style="padding-left: 40px;">A. on the components and raw material used in the manufacturing or assembly of goods quoted ex-works or ex-factory;</p> <p style="padding-left: 40px;">or</p> <p style="padding-left: 40px;">B. on the previously imported goods of foreign origin quoted ex-warehouse, ex-showroom, or off-the-shelf.</p> <p>ii) all applicable taxes which will be payable on the goods if the contract is awarded.</p> <p>iii) the price for inland transportation, insurance, and other local costs incidental to delivery of the goods to their final destination, if specified in the BDS.</p> <p>iv) the price of other (incidental or allied) services, if any, listed in the BDS.</p> <p>b) For goods offered from abroad: : (Not Applicable)</p> <p>i) the price of the goods shall be quoted CIF named port of destination, or CIP border point, or CIP named place of destination, in the Procuring Agency's country, as specified in the BDS. In quoting the price, the Bidder shall be free to use transportation through carriers registered in</p>

		<p>any eligible countries. Similarly, the Bidder may obtain insurance services from any eligible source country. or</p> <p>ii) the price of the goods quoted FOB port of shipment (or FCA, as the case may be), if specified in the BDS. or</p> <p>iii) the price of goods quoted CFR port of destination (or CPT as the case may be), if specified in the BDS.</p> <p>iv) the price for inland transportation, insurance, and other local costs incidental to delivery of the goods from the port of entry to their final destination, if specified in the BDS.</p> <p>v) the price of (incidental) services, if any, listed in the BDS.</p>
	<b>15.7</b>	<p>Prices proposed on the Price Schedule for goods and related services shall be disaggregated, where appropriate as indicated in this Clause. This desegregation shall be solely for the purpose of facilitating the comparison of Bids by the Procuring Agency. This, shall not in any way limit the Procuring Agency's right to contract on any of the terms and conditions offered:</p> <p><b>a) For Goods: -</b></p> <p>i) the price of the Goods, quoted as per applicable INCOTERMS as specified in the <b>BDS</b>.</p> <p>ii) all customs duties, sales tax, and other taxes applicable on goods or on the components and raw materials used in their manufacture or assembly, if the contract is awarded to the Bidder, and</p> <p><b>b) For Related Services</b></p> <p>The price of the related services, and</p> <p>ii) All customs duties, sales tax and other taxes applicable in Pakistan, paid or payable, on the related services, if the contract is awarded to the Bidder.</p>
	<b>15.8</b>	<p>Prices quoted by the Bidder shall be fixed during the Bidder's performance of the contract and not subject to variation on any account. A Bid submitted with an adjustable price will be treated as non-responsive and shall be rejected, pursuant to ITB 28.</p>
	<b>15.9</b>	<p>If so indicated in the Invitation to Bids and Instructions to Bidders, that Bids are being invited for individual contracts (Lots) or for any combination of contracts (packages), Bidders wishing to offer any price reduction for the award of more than one contract shall specify in their Bid the price reductions applicable to each package, or alternatively, to individual contracts (Lots) within a package.</p>

<b>16. Bid Currencies</b>	<b>16.1</b>	<p>Prices shall be quoted in the following currencies:</p> <p>a) For goods and services that the Bidder will deliver from within Pakistan or outside Pakistan, the prices shall be quoted only in Pakistani Rupees, unless otherwise specified in the <b>BDS</b>.</p> <p>b) For goods and related services that the Bidder will deliver from outside Pakistan, or for imported parts or components of goods and related services originating outside Pakistan, the Bid prices shall be quoted in any freely convertible currency of another country. If the Bidder wishes to be paid in a combination of amounts in different currencies, it may quote its price accordingly but use no more than three foreign currencies. (Not Applicable)</p>
	<b>16.2</b>	<p>For the purposes of comparison of bids quoted in different currencies, the price shall be converted into a single currency specified in the bidding documents. The rate of exchange shall be the selling rate, prevailing on the date of opening of (financial part of) bids specified in the bidding documents, as notified by the State Bank of Pakistan on that day. (Not Applicable)</p>
	<b>16.3</b>	<p>Bidders shall indicate details of their expected foreign currency requirements in the Bid. (Not Applicable)</p>
	<b>16.4</b>	<p>Bidders may be required by the Procuring Agency to clarify their foreign currency requirements and to substantiate that the amounts included in Lump Sum and in the <b>SCC</b> are reasonable and responsive to <b>ITB 16.1</b>. (Not Applicable)</p>
<b>17. Bid Validity Period</b>	17.1	<p>Bids shall remain valid for the period specified in the <b>BDS</b> after the Bid submission deadline prescribed by the Procuring Agency. A Bid valid for a shorter period shall be rejected by the Procuring Agency as non-responsive. The period of Bid validity will be determined from the complementary bid securing instrument i.e. the expiry period of bid security or bid securing declaration as the case may be.</p>
	17.2	<p>Under exceptional circumstances, prior to the expiration of the initial Bid validity period, the Procuring Agency may request the Bidders' consent to an extension of the period of validity of their Bids only once, for the period not more than the period of initial bid validity. The request and the Bidders responses shall be made in writing or in electronic forms that provide record of the content of communication. The Bid Security provided under <b>ITB 18</b> shall also be suitably extended. A Bidder may refuse the request without forfeiting its Bid security or causing to be executed its Bid Securing Declaration. A Bidder agreeing to the request will</p>

		not be required nor permitted to modify its Bid, but will be required to extend the validity of its Bid Security or Bid Securing Declaration for the period of the extension, and in compliance with <b>ITB 18</b> in all respects.
	17.3	If the award is delayed by a period exceeding sixty (60) days beyond the expiry of the initial Bid validity period, the contract price may be adjusted by a factor specified in the request for extension. However, the Bid evaluation shall be based on the already quoted Bid Price without taking into consideration on the above correction.
<b>18. Bid Security or Bid Securing Declaration</b>	<b>18.1</b>	Pursuant to <b>ITB 11</b> , unless otherwise specified in the <b>BDS</b> , the Bidder shall furnish as part of its Bid, a Bid Security in form of fixed amount not exceeding five percent of the estimated value of procurement determined by the procuring agency and in the amount and currency specified in the <b>BDS</b> or Bid Securing Declaration as specified in the <b>BDS</b> in the format provided in <b>Section VI (Standard Forms)</b> .
	<b>18.2</b>	The Bid Security or Bid Securing Declaration is required to protect the Procuring Agency against the risk of Bidder's conduct which would warrant the security's forfeiture, pursuant to <b>ITB 18.9</b> .
	<b>18.3</b>	The Bid Security shall be denominated in the local currency, and it shall be in the form specified in the <b>BDS</b> which shall be in any of the following: <ul style="list-style-type: none"> <li>a) a bank guarantee, an irrevocable letter of credit issued by a Scheduled bank in the form provided in the Bidding Documents or another form acceptable to the Procuring Agency and valid for twenty-eight (28) days beyond the end of the validity of the Bid. This shall also apply if the period for Bid Validity is extended. In either case, the form must include the complete name of the Bidder;</li> <li>b) a cashier's or certified cheque; or</li> <li>c) another security if indicated in the <b>BDS</b></li> </ul>
	<b>18.4</b>	The Bid Security or Bid Securing Declaration shall be in accordance with the Form of the Bid Security or Bid Securing Declaration included in <b>Section VI (Standard Forms)</b> or another form approved by the Procuring Agency prior to the Bid submission.
	<b>18.5</b>	The Bid Security shall be payable promptly upon written demand by the Procuring Agency in case any of the conditions listed in <b>ITB 18.9</b> are invoked.

	<b>18.6</b>	Any Bid not accompanied by a Bid Security or Bid Securing Declaration in accordance with <b>ITB 18.1 or 18.3</b> shall be rejected by the Procuring Agency as non-responsive, pursuant to <b>ITB 28</b> .
	<b>18.7</b>	<p>Unsuccessful Bidders' Bid Security will be discharged or returned as promptly as possible, however in no case later than thirty (30) days after the expiration of the period of Bid Validity prescribed by the Procuring Agency pursuant to <b>ITB 17</b>. The Procuring Agency shall make no claim to the amount of the Bid Security, and shall promptly return the Bid Security document, after whichever of the following that occurs earliest:</p> <ul style="list-style-type: none"> <li>(a) the expiry of the Bid Security;</li> <li>(b) the entry into force of a procurement contract and the provision of a performance security (or guarantee), for the performance of the contract if such a security (or guarantee), is required by the Bidding documents;</li> <li>(c) the rejection by the Procuring Agency of all Bids;</li> <li>(d) the withdrawal of the Bid prior to the deadline for the submission of Bids, unless the Bidding documents stipulate that no such withdrawal is permitted.</li> </ul>
	<b>18.8</b>	The successful Bidder's Bid Security will be discharged upon the Bidder signing the contract pursuant to <b>ITB 41</b> , or furnishing the performance security (or guarantee), pursuant to <b>ITB 42</b> .
	<b>18.9</b>	<p>The Bid Security may be forfeited or the Bid Securing Declaration executed:</p> <ul style="list-style-type: none"> <li>a) if a Bidder: <ul style="list-style-type: none"> <li>i) withdraws its Bid during the period of Bid Validity as specified by the Procuring Agency, and referred by the bidder on the Form of Bid except as provided for in <b>ITB 17.2</b>; or</li> <li>ii) does not accept the correction of errors pursuant to <b>ITB 30.3</b>; or</li> </ul> </li> <li>b) in the case of a successful Bidder, if the Bidder fails: <ul style="list-style-type: none"> <li>i) to sign the contract in accordance with <b>ITB 41</b>; or</li> </ul> </li> </ul>

		ii) to furnish performance security (or guarantee) in accordance with <b>ITB 42</b> .
<b>19. Alternative Bids by Bidders</b>	<b>19.1</b>	Bidders shall submit offers that comply with the requirements of the Bidding Documents, including the basic Bidder's technical design as indicated in the specifications and Schedule of Requirements. Alternatives will not be considered, unless specifically allowed for in the <b>BDS</b> . If so allowed, <b>ITB 19.2</b> shall prevail.
	<b>19.2</b>	When alternative schedule for delivery of goods is explicitly invited, a statement of that effect will be included in the <b>BDS</b> as will the method for evaluating different schedule for delivery of goods.
	<b>19.3</b>	If so allowed in the <b>BDS</b> , Bidders wishing to offer technical alternatives to the requirements of the Bidding Documents must also submit a Bid that complies with the requirements of the Bidding Documents, including the basic technical design as indicated in the specifications. In addition to submitting the basic Bid, the Bidder shall provide all information necessary for a complete evaluation of the alternative by the Procuring Agency, including technical specifications, breakdown of prices, and other relevant details. Only the technical alternatives, if any, of the Most Advantageous Bidder conforming to the basic technical requirements (without altering the bid price) shall be considered by the Procuring Agency.
<b>20. Withdrawal, Substitution, and Modification of Bids</b>	<b>20.1</b>	Before bid submission deadline, any bidder may withdraw, substitute, or modify its Bid after it has been submitted by sending a written notice, duly signed by an authorized representative, and the corresponding substitution or modification must accompany the respective written notice. (as per provisions of E-PADS)
	<b>20.2</b>	Bids requested to be withdrawn in accordance with ITB 20.1 shall be returned unopened to the Bidders. (as per provisions of E-PADS)
<b>21. Format and Signing of Bid</b>	<b>21.1</b>	The scanned form of "ORIGINAL" Signed Bid will be uploaded by each Bidder on E-PADS. Each page of the Bid, except for un-amended printed literature, must be signed and stamped by the Bidder or a person or persons duly authorized to sign on behalf of the Bidder bid before uploading on E-PADS.
	<b>21.2</b>	This authorization shall consist of a written confirmation as specified in the <b>BDS</b> and shall be attached to the Bid. The name and position held by each person signing the authorization must be typed or printed below the signature.
	<b>21.3</b>	Any interlineations, erasures, or overwriting shall be valid only if they are signed by the person or persons signing the Bidder.

**D. SUBMISSION OF BIDS**

<b>22. Sealing and Marking of Bids</b>	<b>22.1</b>	<p>In case of Single Stage One Envelope Procedure, the Bidder shall seal the original and each copy of the Bid in separate envelopes, duly marking the envelopes as “ORIGINAL” and “COPY.” The envelopes shall then be sealed in an outer envelope securely sealed in such a manner that opening and resealing cannot be achieved undetected. (as per provisions of E-PADS)</p> <p>In case of Single Stage Two Envelope Procedure, the technical &amp; financial bids must be uploaded by respective bidder on E-PADS in respective section, before the closing date &amp; time of bid submission.</p> <p><b>Note:</b> <i>The envelopes shall be sealed and marked in accordance with the bidding procedure adopted as referred in Rule-36 of PPR-2004. (Not Applicable)</i></p>
	<b>22.2</b>	<p>The inner and outer envelopes shall: (Not Applicable)</p> <p>a) be addressed to the Procuring Agency at the address given in the <b>BDS</b>; and</p> <p>b) bear the title of the subject procurement or Project name, as the case may be as indicated in the <b>BDS</b>, the Invitation to Bids (ITB) title and number indicated in the <b>BDS</b>, and a statement: “DO NOT OPEN BEFORE,” to be completed with the time and the date specified in the <b>BDS</b>, pursuant to <b>ITB 23.1</b>.</p>
	<b>22.3</b>	<p>In case of Single Stage Two Envelope Procedure, The Bid shall comprise two parts submitted simultaneously on E-PADS, one called the Technical Proposal and the other Financial Proposal. Each Bidder shall submit his bid as under:</p> <p>a) Bidder shall prepare his <b>TECHNICAL PROPOSAL</b> and <b>FINANCIAL PROPOSAL</b> which will be separately uploaded on E-PADS before closing date &amp; time of bid submission.</p> <p>b) <b>ORIGINAL</b> and each copy of the Bid shall be separately sealed and put in separate envelopes and marked as such. (Not Applicable)</p> <p>c) The envelopes containing the <b>ORIGINAL</b> and copies will be put in one sealed envelope and addressed / identified as given in Sub- Clause 21.2. (Not Applicable)</p>
	<b>22.4</b>	<p>The inner and outer envelopes shall: (Not Applicable)</p>

		<p>a) be addressed to the Procuring Agency at the address provided in the Bidding Data;</p> <p>b) bear the name and identification number of the contract as defined in the Bidding Data; and provide a warning not to open before the time and date for bid opening, as specified in the Bidding Data. pursuant to <b>ITB 23.1</b>.</p> <p>c) In addition to the identification required in Sub- Clause 21.2 hereof, the inner envelope shall indicate the name and address of the bidder to enable the bid to be returned unopened in case it is declared “late” pursuant to Clause IB.24</p>
		If all envelopes are not sealed and marked as required by <b>ITB 22.2, ITB 22.3</b> and <b>ITB 22.4</b> or incorrectly marked, the Procuring Agency will assume no responsibility for the misplacement or premature opening of Bid. (Not Applicable)
<b>23. Deadline for Submission of Bids</b>	<b>23.1</b>	Bids shall be received through E-PADS by the Procuring Agency no later than the date and time specified in the <b>BDS</b> . The scanned form of complete technical & financial bid to be uploaded on E-PADS before the closing date and time of submission of bids.
	<b>23.2</b>	The Procuring Agency may, in exceptional circumstances and at its discretion, extend the deadline for the submission of Bids by amending the Bidding Documents in accordance with <b>ITB 9</b> , in which case all rights and obligations of the Procuring Agency and Bidders previously subject to the deadline will thereafter be subject to the new deadline.
<b>24. Late Bids</b>	<b>24.1</b>	The Procuring Agency shall not consider for evaluation any Bid that arrives after the deadline for submission of Bids, in accordance with <b>ITB 23</b> .
	<b>24.2</b>	Any Bid received by the Procuring Agency after the deadline for submission of Bids shall be declared late, recorded, rejected and returned unopened to the Bidder.
<b>25. Withdrawal of Bids</b>	<b>25.1</b>	A Bidder may withdraw its Bid after it has been submitted, provided that written notice of the withdrawal of the Bid, is received by the Procuring Agency prior to the deadline for submission of Bids. (as per provisions of E-PADS)
	<b>25.2</b>	Revised bid may be submitted after the withdrawal of the original bid in accordance with the provisions referred in <b>ITB 22</b> . (as per provisions of E-PADS)

### E. OPENING AND EVALUATION OF BIDS

<b>26. Opening of Bids</b>	<b>26.1</b>	The Procuring Agency will open all Bids on E-PADS only, in public, in the presence of Bidders’ or their representatives who
----------------------------	-------------	---

		choose to attend, and other parties with a legitimate interest in the Bid proceedings at the place, on the date and at the time, specified in the <b>BDS</b> . The Bidders' representatives present shall sign a register as proof of their attendance.
	<b>26.2</b>	First, envelopes marked "WITHDRAWAL" shall be opened and read out and the envelope with the corresponding bid shall not be opened, but returned to the Bidder. No bid withdrawal shall be permitted unless the corresponding Withdrawal Notice contains a valid authorization to request the withdrawal and is read out at bid opening. (as per provisions of E-PADS)
	<b>26.3</b>	Second, outer envelopes marked "SUBSTITUTION" shall be opened. The inner envelopes containing the Substitution Bid shall be exchanged for the corresponding Original Bid being substituted, which is to be returned to the Bidder unopened. No envelope shall be substituted unless the corresponding Substitution Notice contains a valid authorization to request the substitution and is read out and recorded at bid opening. (as per provisions of E-PADS)
	<b>26.4</b>	Next, outer envelopes marked "MODIFICATION" shall be opened. No Technical Proposal and/or Financial Proposal shall be modified unless the corresponding Modification Notice contains a valid authorization to request the modification and is read out and recorded at the opening of the Bids. Any Modification shall be read out along with the Original Bid except in case of Single Stage Two Envelope Procedure where only the Technical Proposal, both Original as well as Modification, are to be opened, read out, and recorded at the opening. Financial Proposal, both Original and Modification, will remain unopened till the prescribed financial bid opening date. (as per provisions of E-PADS)
	<b>26.5</b>	In case of Single Stage One Envelope Procedure, the Bidders names, the Bid prices, the total amount of each Bid and of any alternative Bid (if alternatives have been requested or permitted), any discounts, the presence or absence of Bid Security, Bid Securing Declaration and such other details as the Procuring Agency may consider appropriate, will be announced by the Procurement Evaluation Committee.
	<b>26.6</b>	In case of Single Stage Two Envelope Procedure, the Procuring Agency will open the Technical Proposals on E-PADS in public at the address, date and time specified in the <b>BDS</b> in the presence of Bidders' designated representatives who choose to attend and other parties with a legitimate interest in the Bid proceedings. The Financial Proposals will remain unopened and will be

		retained on E-PADS by the Procuring Agency until the specified time of their opening.
	<b>26.7</b>	The Technical Proposals on E-PADS shall be opened one at a time, and the following read out and recorded: (a) the name of the Bidder; (b) the presence of a Bid Security, if required; and (c) Any other details as the Procuring Agency may consider appropriate.
	<b>26.8</b>	Bids not opened and not read out at the Bid opening shall not be considered further for evaluation, irrespective of the circumstances. In particular, any discount offered by a Bidder which is not read out at Bid opening shall not be considered further.
	<b>26.9</b>	Bidders are advised to send in a representative with the knowledge of the content of the Bid who shall verify the information read out from the submitted documents. Failure to send a representative or to point out any un-read information by the sent Bidder's representative shall indemnify the Procuring Agency against any claim or failure to read out the correct information contained in the Bidder's Bid.
	<b>26.10</b>	No Bid will be rejected at the time of Bid opening except for late Bids which will be returned unopened to the Bidder, pursuant to <b>ITB 24</b> .
	<b>26.11</b>	The Procuring Agency shall prepare minutes of the Bid opening. The record of the Bid opening shall include, as a minimum: the name of the Bidder, the Bid price if applicable, including any discounts and alternative offers and the presence or absence of a Bid Security or Bid Securing Declaration.
	<b>26.12</b>	The Bidders' representatives who are present shall be requested to sign on the attendance sheet. The omission of a Bidder's signature on the record shall not invalidate the contents and affect the record. A copy of the record shall be distributed to all the Bidders.
	<b>26.13</b>	A copy of the minutes of the Bid opening shall be furnished to individual Bidders upon request.
	<b>26.14</b>	In case of Single Stage Two Envelop Bidding Procedure, after the evaluation and approval of technical proposal the procuring agency, shall at a time within the bid validity period, publically open the financial proposals of the technically accepted bids only, on E-PADS. The financial proposal of bids found technically non-responsive will not be opened in any case, subject to redress of the grievances from all tiers of grievances.
<b>27. Confidentiality</b>	<b>27.1</b>	Information relating to the examination, clarification, evaluation and comparison of Bids and recommendation of contract award shall not be disclosed to Bidders or any other

		persons not officially concerned with such process until the time of the announcement of the respective evaluation report.
	<b>27.2</b>	Any effort by a Bidder to influence the Procuring Agency processing of Bids or award decisions may result in the rejection of its Bid.
	<b>27.3</b>	Notwithstanding <b>ITB 27.2</b> from the time of Bid opening to the time of contract award, if any Bidder wishes to contact the Procuring Agency on any matter related to the Bidding process, it should do so in writing or in electronic forms that provides record of the content of communication.
<b>28. Clarification of Bids</b>	<b>28.1</b>	To assist in the examination, evaluation and comparison of Bids (and post-qualification if applicable) of the Bidders, the Procuring Agency may, ask any Bidder for a clarification of its Bid including breakdown of prices. Any clarification submitted by a Bidder that is not in response to a request by the Procuring Agency shall not be considered.
	<b>28.2</b>	The request for clarification and the response shall be in writing or in electronic forms that provide record of the content of communication. In case of Single Stage Two Envelope Procedure, no change in the prices or substance of the Bid shall be sought, offered, or permitted, whereas in case of Single Stage One Envelope Procedure, only the correction of arithmetic errors discovered by the Procuring Agency in the evaluation of Bids should be sought in accordance with <b>ITB 31</b> .
	<b>28.3</b>	The alteration or modification in THE BID which in any affect the following parameters will be considered as a change in the substance of a bid: <ul style="list-style-type: none"> <li>a) evaluation &amp; qualification criteria;</li> <li>b) required scope of work or specifications;</li> <li>c) all securities requirements;</li> <li>d) tax requirements;</li> <li>e) terms and conditions of bidding documents.</li> <li>f) change in the ranking of the bidder</li> </ul>
	<b>28.4</b>	From the time of Bid opening to the time of Contract award if any Bidder wishes to contact the Procuring Agency on any matter related to the Bid it should do so in writing or in electronic forms that provide record of the content of communication.
<b>29. Preliminary Examination of Bids</b>	<b>29.1</b>	Prior to the detailed evaluation of Bids, the Procuring Agency will determine whether each Bid: <ul style="list-style-type: none"> <li>a) meets the eligibility criteria defined in <b>ITB 3</b> and <b>ITB 4</b>;</li> </ul>

		<ul style="list-style-type: none"> <li>b) has been prepared as per the format and contents defined by the Procuring Agency in the Bidding Documents;</li> <li>c) has been properly signed;</li> <li>d) is accompanied by the required securities; and</li> <li>e) is substantially responsive to the requirements of the Bidding Documents.</li> </ul> <p>The Procuring Agency's determination of a Bid's responsiveness will be based on the contents of the Bid itself.</p>
	<b>29.2</b>	<p>A substantially responsive Bid is one which conforms to all the terms, conditions, and specifications of the Bidding Documents, without material deviation or reservation. A material deviation or reservation is one that: -</p> <ul style="list-style-type: none"> <li>a) affects in any substantial way the scope, quality, or performance of the Services;</li> <li>b) limits in any substantial way, inconsistent with the Bidding Documents, the Procuring Agency's rights or the Bidders obligations under the Contract; or</li> <li>c) if rectified, would affect unfairly the competitive position of other Bidders presenting substantially responsive Bids.</li> </ul>
	<b>29.3</b>	<p>The Procuring Agency will confirm that the documents and information specified under <b>ITB 11, 12 and 13</b> have been provided in the Bid. If any of these documents or information is missing, or is not provided in accordance with the Instructions to Bidders, the Bid shall be rejected.</p>
	<b>29.4</b>	<p>The Procuring Agency may waive off any minor informality, nonconformity, or irregularity in a Bid which does not constitute a material deviation, provided such waiver does not prejudice or affect the relative ranking of any Bidder.</p> <p><b><i>Explanation:</i></b> <i>A minor informality, non-conformity or irregularity is one that is merely a matter of form and not of substance. It also pertains to some immaterial defect in a Bid or variation of a bid from the exact requirements of the invitation that can be corrected or waived without being prejudicial to other bidders. The defect or variation is immaterial when the effect on quantity, quality, or delivery is negligible when contrasted with the total cost or scope of the supplies or services being acquired. The Procuring Agency either shall give the bidder an opportunity to cure any deficiency resulting from a minor informality or irregularity in a bid or waive the deficiency, whichever is advantageous to the Procuring Agency.</i></p>

		<p><i>Examples of minor informalities or irregularities include failure of a bidder to –</i></p> <p>(a) <i>Submit the number of copies of signed bids required by the invitation;</i></p> <p>(b) <i>Furnish required information concerning the number of its employees;</i></p> <p>(c) <i>the firm submitting a bid has formally adopted or authorized, before the date set for opening of bids, the execution of documents by typewritten, printed, or stamped signature and submits evidence of such authorization and the bid carries such a signature.</i></p>
	<b>29.5</b>	<p>Provided that a Technical Bid is substantially responsive, the Procuring Agency may request the Bidder to submit the necessary information or documentation, within a reasonable period of time, to rectify nonmaterial nonconformities or omissions in the Technical Bid related to documentation requirements. Requesting information or documentation on such nonconformities shall not be related to any such aspect of the technical Proposal linked with the ranking of the bidders. Failure of the Bidder to comply with the request may result in the rejection of its Bid.</p>
	<b>29.6</b>	<p>Provided that a Technical Bid is substantially responsive, the Procuring Agency shall rectify quantifiable nonmaterial nonconformities or omissions related to the Financial Proposal. To this effect, the Bid Price shall be adjusted, for comparison purposes only, to reflect the price of the missing or nonconforming item or component.</p>
	<b>29.7</b>	<p>If a Bid is not substantially responsive, it will be rejected by the Procuring Agency and may not subsequently be evaluated for complete technical responsiveness.</p>
<b>30. Examination of Terms and Conditions; Technical Evaluation</b>	<b>30.1</b>	<p>The Procuring Agency shall examine the Bid to confirm that all terms and conditions specified in the <b>GCC</b> and the <b>SCC</b> have been accepted by the Bidder without any material deviation or reservation.</p>
	<b>30.2</b>	<p>The Procuring Agency shall evaluate the technical aspects of the Bid submitted in accordance with <b>ITB 22</b>, to confirm that all requirements specified in <b>Section V – Schedule of Requirements, Technical Specifications of</b> the Bidding Documents have been met without material deviation or reservation.</p>
	<b>30.3</b>	<p>If after the examination of the terms and conditions and the technical evaluation, the Procuring Agency determines that the</p>

		Bid is not substantially responsive in accordance with <b>ITB 29</b> , it shall reject the Bid.
<b>31. Correction of Errors</b>	<b>31.1</b>	<p>Bids determined to be substantially responsive will be checked for any arithmetic errors. Errors will be corrected as follows: -</p> <ul style="list-style-type: none"> <li>a) if there is a discrepancy between unit prices and the total price that is obtained by multiplying the unit price and quantity, the unit price shall prevail, and the total price shall be corrected, unless in the opinion of the Procuring Agency there is an obvious misplacement of the decimal point in the unit price, in which the total price as quoted shall govern and the unit price shall be corrected;</li> <li>b) if there is an error in a total corresponding to the addition or subtraction of sub-totals, the sub-totals shall prevail and the total shall be corrected; and</li> <li>c) where there is a discrepancy between the amounts in figures and in words, the amount in words will govern.</li> <li>d) Where there is discrepancy between grand total of price schedule and amount mentioned on the Form of Bid, the amount referred in Price Schedule shall be treated as correct subject to elimination of other errors.</li> </ul>
	<b>31.2</b>	The amount stated in the Bid will, be adjusted by the Procuring Agency in accordance with the above procedure for the correction of errors and, with, the concurrence of the Bidder, shall be considered as binding upon the Bidder. If the Bidder does not accept the corrected amount, its Bid will then be rejected, and the Bid Security may be forfeited or the Bid Securing Declaration may be executed in accordance with <b>ITB 18.9</b> .
<b>32. Conversion to Single Currency</b>	<b>32.1</b>	To facilitate evaluation and comparison, the Procuring Agency will convert all Bid prices expressed in the amounts in various currencies in which the Bid prices are payable. For the purposes of comparison of bids quoted in different currencies, the price shall be converted into a single currency specified in the bidding documents. The rate of exchange shall be the selling rate, prevailing on the date of opening of (financial part of) bids specified in the bidding documents, as notified by the State Bank of Pakistan on that day. (Not Applicable)
	<b>32.2</b>	The currency selected for converting Bid prices to a common base for the purpose of evaluation, along with the source and date of the exchange rate, are specified in the <b>BDS</b> . (Not Applicable)

<b>33. Evaluation of Bids</b>	<b>33.1</b>	The Procuring Agency shall evaluate and compare only the Bids determined to be substantially responsive, pursuant to <b>ITB 29</b> .
	<b>33.2</b>	In evaluating the Technical Proposal of each Bid, the Procuring Agency shall use the criteria and methodologies listed in the BDS and in terms of Statement of Requirements and Technical Specifications. No other evaluation criteria or methodologies shall be permitted.
	<b>33.3</b>	<p>The Procuring Agency's evaluation of a Bid will take into account:</p> <ul style="list-style-type: none"> <li>a) in the case of goods manufactured in Pakistan or goods of foreign origin already imported in Pakistan, Income Tax, General Sales Tax and other similar/applicable taxes, which will be payable on the goods if a contract is awarded to the Bidder;</li> <li>b) in the case of goods of foreign origin offered from abroad, customs duties and other similar import taxes which will be payable on the goods if the contract is awarded to the Bidder. (Not Applicable)</li> </ul>
	<b>33.4</b>	The comparison shall be between the EXW price of the goods offered from within Pakistan, such price to include all costs, as well as duties and taxes paid or payable on components and raw material incorporated or to be incorporated in the goods, and named port of destination, border point, or named place of destination) in accordance with applicable INCOTERM in the price of the goods offered from outside Pakistan. (Not Applicable)
	<b>33.5</b>	<p>In evaluating the Bidders, the evaluation committee will, in addition to the Bid price quoted in accordance with ITB 15.1, take account of one or more of the following factors as specified in the <b>BDS</b>, and quantified in ITB 32.5:</p> <ul style="list-style-type: none"> <li>a) Cost of inland transportation, insurance, and other costs within the Pakistan incidental to delivery of the goods to their final destination. (Not Applicable)</li> <li>b) delivery schedule offered in the Bid;</li> <li>c) deviations in payment schedule from that specified in the Special Conditions of Contract;</li> <li>d) the cost of components, mandatory spare parts, and service;</li> </ul>

		<ul style="list-style-type: none"> <li>e) the availability (in Pakistan) of spare parts and after-sales services for the equipment offered in the Bid;</li> <li>f) the projected operating and maintenance costs during the life of the equipment;</li> <li>g) the performance and productivity of the equipment offered; and/or</li> <li>h) other specific criteria indicated in the <b>TBS</b> and/or in the Technical Specifications.</li> </ul>
	<p><b>33.5</b></p>	<p>For factors retained in <b>BDS</b>, pursuant to ITB 33.4 one or more of the following quantification methods will be applied, as detailed in the <b>BDS</b>:</p> <p><i>(a) Inland transportation from EXW/port of entry/border point, Insurance and incidentals.</i></p> <p>Inland transportation, insurance, and other incidental costs for delivery of the goods from EXW/port of entry/border point to Project Site named in the <b>BDS</b> will be computed for each Bid by the PA on the basis of published tariffs by the rail or road transport agencies, insurance companies, and/or other appropriate sources. To facilitate such computation, Bidder shall furnish in its Bid the estimated dimensions and shipping weight and the approximate EXW or as per applicable INCOTERM value of each package. The above cost will be added by the Procuring Agency to EXW or as per applicable INCOTERM price. (Not Applicable)</p> <p><i>(b) Delivery schedule.</i></p> <ul style="list-style-type: none"> <li>i) The Procuring Agency requires that the goods under the Invitation for Bids shall be delivered (shipped) at the time specified in the Schedule of Requirements. The estimated time of arrival of the goods at the Project Site will be calculated for each Bid after allowing for reasonable international and inland transportation time. Treating the Bid resulting in such time of arrival as the base, a delivery “adjustment” will be calculated for other Bids by applying a percentage, specified in the <b>BDS</b>, of the EXW or as per applicable INCOTERM price for each week of delay beyond the base, and this will be added to the</li> </ul>

		<p>Bid price for evaluation. No credit shall be given to early delivery. (Not Applicable)</p> <p style="text-align: center;"><b>Or</b></p> <p>ii) The goods covered under this invitation are required to be delivered (shipped) within an acceptable range of weeks specified in the Schedule of Requirement. <b>No credit will be given to earlier deliveries, and Bids offering delivery beyond this range will be treated as non-responsive.</b> Within this acceptable range, an adjustment per week, as specified in the <b>BDS</b>, will be added for evaluation to the Bid price of Bids offering deliveries later than the earliest delivery period specified in the Schedule of Requirements. (Not Applicable)</p> <p style="text-align: center;"><b>Or</b></p> <p>(iii) The goods covered under this invitation are required to be delivered (shipped) in partial shipments, as specified in the Schedule of Requirements. Bids offering deliveries earlier or later than the specified deliveries will be adjusted in the evaluation by adding to the Bid price a factor equal to a percentage, specified in the <b>BDS</b>, of EXW or as per applicable INCOTERM price per week of variation from the specified delivery schedule. (Not Applicable)</p> <p>(c) <i>Deviation in payment schedule.</i></p> <p>i) Bidders shall state their Bid price for the payment schedule outlined in the <b>SCC</b>. Bids will be evaluated on the basis of this base price. Bidders are, however, permitted to state an alternative payment schedule and indicate the reduction in Bid price they wish to offer for such alternative payment schedule. The Procuring Agency may consider the alternative payment schedule offered by the selected Bidder. (Not Applicable)</p> <p style="text-align: center;"><b>Or</b></p>
--	--	--

		<p>ii) The <b>SCC</b> stipulates the payment schedule offered by the Procuring Agency. If a Bid deviates from the schedule and if such deviation is considered acceptable to the Procuring Agency, the Bid will be evaluated by calculating interest earned for any earlier payments involved in the terms outlined in the Bid as compared with those stipulated in this invitation, at the rate per annum specified in the <b>BDS</b>. (Not Applicable)</p> <p><i>(d) Cost of spare parts</i></p> <p>i) The list of items and quantities of major assemblies, components, and selected spare parts, likely to be required during the initial period of operation specified in the <b>BDS</b>, is annexed to the Technical Specifications. The total cost of these items, at the unit prices quoted in each Bid, will be added to the Bid price. (Not Applicable)</p> <p style="text-align: center;"><b>Or</b></p> <p>ii) The Procuring Agency will draw up a list of high-usage and high-value items of components and spare parts, along with estimated quantities of usage in the initial period of operation specified in the <b>BDS</b>. The total cost of these items and quantities will be computed from spare parts unit prices submitted by the Bidder and added to the Bid price. (Not Applicable)</p> <p style="text-align: center;"><b>Or</b></p> <p>iii) The Procuring Agency will estimate the cost of spare parts usage in the initial period of operation specified in the <b>BDS</b>, based on information furnished by each Bidder, as well as on past experience of the Procuring Agency or other Procuring Agency's in similar situations. Such costs shall be added to the Bid price for evaluation. (Not Applicable)</p> <p><i>(e) Spare parts and after sales service facilities in Pakistan</i></p>
--	--	--

		<p>The cost to the Procuring Agency of establishing the minimum service facilities and parts inventories, as outlined in the <b>BDS</b> or elsewhere in the Bidding Documents, if quoted separately, shall be added to the Bid price. (Not Applicable)</p> <p><i>(f) Operating and maintenance costs</i></p> <p>Since the operating and maintenance costs of the goods under procurement form a major part of the life cycle cost of the equipment, these costs will be evaluated in accordance with the criteria specified in the <b>BDS</b> or in the Technical Specifications. (Not Applicable)</p> <p><i>(g) Performance and productivity of the equipment.</i></p> <p>(i) Bidders shall state the guaranteed performance or efficiency in response to the Technical Specification. For each drop in the performance or efficiency below the norm of 100, an adjustment for an amount specified in the <b>BDS</b> will be added to the Bid Price, representing the capitalized cost of additional operating costs over the life of the plant, using the methodology specified in the <b>BDS</b> or in the Technical Specifications. (Not Applicable)</p> <p style="text-align: center;">Or</p> <p>(ii) Goods offered shall have a minimum productivity specified under the relevant provision in the Technical Specifications to be considered responsive. Evaluation shall be based on the cost per unit of the actual productivity of goods offered in the Bid, and adjustment will be added to the Bid price using the methodology specified in the <b>BDS</b> or in the Technical Specifications. (Not Applicable)</p> <p><i>(h) Specific additional criteria.</i></p> <p>Other specific additional criteria to be considered in the evaluation and the evaluation method shall be detailed in the <b>BDS</b> and/or the Technical Specifications. (Not Applicable)</p>
	<b>33.6</b>	If these Bidding Documents allow Bidders to quote separate prices for different Lots, and the award to a single Bidder of

		multiple Lots, the methodology of evaluation to determine the lowest evaluated Lot combinations, including any discounts offered in the Form of Bid, is specified in the <b>BDS</b> . (Not Applicable)
<b>34. Domestic Preference</b>	<b>34.1</b>	If the <b>BDS</b> so specifies, the Procuring Agency will grant a margin of preference to certain goods in line with the rules, regulations, regulatory guides or instructions issued by the Authority from time to time. (Not Applicable)
<b>35. Determination of Most Advantageous Bid</b>	<b>35.1</b>	In case where the Procuring Agency adopts the Cost Based Evaluation Technique and, the Bid with the lowest evaluated price from amongst those which are eligible, compliant and substantially responsive shall be the Most Advantageous Bid.
	<b>35.2</b>	<p>The Procuring Agency may adopt the Quality &amp; Cost Based Selection Technique due to the following two reasons:</p> <ol style="list-style-type: none"> <li>i. Where the Procuring Agency knows about the main features, usage and output of the products; however not clear about the complete features, technical specifications and functionalities of the goods to be procured and requires the bidders to submit their proposals defining those features, specifications and functionalities; or</li> <li>ii. Where the Procuring Agency, in addition to the mandatory requirements and mandatory technical specifications, requires parameters <b>specified in Evaluation Criteria</b> to be evaluated while determining the quality of the goods:</li> </ol> <p>In such cases, the Procuring Agency may allocate certain weightage to these factors as a part of Evaluation Criteria, and may determine the ranking of the bidders on the basis of combined evaluation in accordance with provisions of Rule 2(1)(h) of PPR-2004.</p>
<b>36. Post-qualification of Bidder and/or Abnormally Low Financial Proposal</b>	<b>36.1</b>	<p>After determining the Most Advantageous Bid, if neither the pre-qualification was undertaken separately nor any qualification parameters were undertaken as part of determining the Most Advantageous Bid, the Procuring Agency shall carry out the post-qualification of the Bidder using only the requirements specified in the <b>BDS</b>.</p> <p>In case of International Tendering, the parameters for incorporation or licensing within Pakistan may be fulfilled as part of post qualification. (Not Applicable)</p>
	<b>36.2</b>	Where the Bid price is considered to be abnormally low, the Procuring Agency shall perform price analysis either during

	<p>determination of Most Advantageous Bid or as a part of the post-qualification process. The following process shall apply:</p> <p>(a) The Procuring Agency may reject a Bid if the Procuring Agency has determined that the price in combination with other constituent elements of the Bid is abnormally low in relation to the subject matter of the procurement (i.e. scope of the procurement or ancillary services) and raises concerns as to the capability and capacity of the respective Bidder to perform that contract;</p> <p>(b) Before rejecting an abnormally low Bid the Procuring Agency shall request the Bidder an explanation of the Bid or of those parts which it considers contribute to the Bid being abnormally low; take account of the evidence provided in response to a request in writing; and subsequently verify the Bid or parts of the Bid being abnormally low;</p> <p>(c) The decision of the Procuring Agency to reject a Bid and reasons for the decision shall be recorded in the procurement proceedings and promptly communicated to the Bidder concerned;</p> <p>(d) The Procuring Agency shall not incur any liability solely by rejecting abnormally Bid; and</p> <p>(e) An abnormally low Bid means, in the light of the Procuring Agency's estimate and of all the Bids submitted, the Bid appears to be abnormally low by not providing a margin for normal levels of profit.</p> <p>Guidance for Procuring Agency: In order to identify the Abnormally Low Bid (ALB) following approaches can be considered to minimize the scope of subjectivity:</p> <p>(i) Comparing the bid price with the cost estimate;</p> <p>(ii) Comparing the bid price with the bids offered by other bidders submitting substantially responsive bids; and</p> <p>(iii) Comparing the bid price with prices paid in similar contracts in the recent past either government- or development partner-funded.</p>
--	---

	<b>36.3</b>	The Procuring Agency will determine to its satisfaction whether the Bidder that is selected as having submitted the most advantageous Bid is qualified to perform the contract satisfactorily, in accordance with the criteria listed in ITB 13.3.
	<b>36.4</b>	The determination will take into account the Bidder's financial, technical, and production capabilities. It will be based upon an examination of the documentary evidence of the Bidder's qualifications submitted by the Bidder, pursuant to ITB 13.3, as well as such other information as the Procuring Agency deems necessary and appropriate. Factors not included in these Bidding Documents shall not be used in the evaluation of the Bidders' qualifications.
	<b>36.5</b>	Procuring Agency may seek "Certificate for Independent Price Determination" from the Bidder and the results of reference checks may be used in determining award of contract. Explanation: The Certificate shall be furnished by the bidder. The bidder shall certify that the price is determined keeping in view of all the essential aspects such as raw material, its processing, value addition, optimization of resources due to economy of scale, transportation, insurance and margin of profit etc.
	<b>36.6</b>	An affirmative determination will be a prerequisite for award of the contract to the Bidder. A negative determination will result in rejection of the Bidder's Bid, in which event the Procuring Agency will proceed to the next ranked bidder to make a similar determination of that Bidder's capabilities to perform satisfactorily.

**F. AWARD OF CONTRACT**

<b>37. Criteria of Award</b>	<b>37.1</b>	<p>Subject to ITB 36 and 38, the Procuring Agency will award the Contract to the Bidder whose Bid has been determined to be substantially responsive to the Bidding Documents and who has been declared as Most Advantageous Bidder, provided that such Bidder has been determined to be:</p> <p>a) eligible in accordance with the provisions of ITB 3;</p> <p>b) is determined to be qualified to perform the Contract satisfactorily; and</p> <p>c) Successful negotiations have been concluded, if any.</p>
<b>38. Negotiations</b>	<b>38.1</b>	<p>Negotiations may be undertaken with the Most Advantageous Bid relating to the following areas:</p> <p>(a) a minor alteration to the technical details of the statement of requirements;</p> <p>(b) reduction of quantities for budgetary reasons, where the reduction is in excess of any provided for in the Bidding documents;</p> <p>(c) a minor amendment to the special conditions of Contract;</p> <p>(d) finalizing payment arrangements;</p> <p>(e) delivery arrangements;</p> <p>(f) the methodology for provision of related services; or</p> <p>(g) clarifying details that were not apparent or could not be finalized at the time of Bidding;</p>
	<b>38.2</b>	<p>Where negotiation fails to result into an agreement, the Procuring Agency may invite the next ranked Bidder for negotiations. Where negotiations are commenced with the next ranked Bidder, the Procuring Agency shall not reopen earlier negotiations.</p>
<b>39. Procuring Agency's Right to reject All Bids</b>	<b>39.1</b>	<p>Notwithstanding <b>ITB 37</b>, the Procuring Agency reserves the right to reject all the bids, and to annul the Bidding process at any time prior to award of contract, without thereby incurring any liability to the affected Bidder or Bidders. However, the Authority (i.e. PPRA) may call from the Procuring Agency the justification of those grounds.</p>
	<b>39.2</b>	<p>Notice of the rejection of all Bids shall be given promptly to all Bidders that have submitted Bids.</p>

	<b>39.3</b>	The Procuring Agency shall upon request communicate to any Bidder the grounds for its rejection of its Bids, but is not required to justify those grounds.
<b>40. Procuring Agency's Right to Vary Quantities at the Time of Award</b>	<b>40.1</b>	The Procuring Agency reserves the right at the time of contract award to increase or decrease the quantity of goods or related services originally specified in these Bidding Documents (schedule of requirements) provided this does not exceed by the percentage indicated in the BDS, without any change in unit price or other terms and conditions of the Bid and Bidding Documents.
<b>41. Notification of Award</b>	<b>41.1</b>	Prior to the award of contract, the Procuring Agency shall issue a Final Evaluation Report giving justification for acceptance or rejection of the bids.
	<b>41.2</b>	Where no complaints have been lodged, the Bidder whose Bid has been accepted will be notified of the award by the Procuring Agency prior to expiration of the Bid Validity period in writing or electronic forms that provide record of the content of communication. The Letter of Acceptance will state the sum that the Procuring Agency will pay the successful Bidder in consideration for the execution of the scope of works as prescribed by the Contract (hereinafter and in the Contract called the "Contract Price).
	<b>41.3</b>	The notification of award will constitute the formation of the Contract, subject to the Bidder furnishing the Performance Security (or guarantee) in accordance with <b>ITB 43</b> and signing of the contract in accordance with <b>ITB 42.2</b> .
	<b>41.4</b>	Upon the successful Bidder's furnishing of the performance security (or guarantee) pursuant to <b>ITB 43</b> , the Procuring Agency will promptly notify each unsuccessful Bidder, the name of the successful Bidder and the Contract amount and will discharge the Bid Security or Bid Securing Declaration of the Bidders pursuant to <b>ITB 18.7</b> .
<b>42. Signing of Contract</b>	<b>42.1</b>	Promptly after notification of award, Procuring Agency shall send the successful Bidder the draft agreement, incorporating all terms and conditions as agreed by the parties to the contract.
	<b>42.2</b>	Immediately after the Redressal of grievance by the GRC, and <b>after fulfillment of all conditions precedent</b> of the Contract Form, the successful Bidder and the Procuring Agency shall sign the contract.

	<b>42.3</b>	Where no formal signing of a contract is required, purchase order issued to the bidder shall be construed to be the contract.
<b>43. Performance Security (or Guarantee)</b>	<b>43.1</b>	After the receipt of the Letter of Acceptance, the successful Bidder, within the specified time, shall deliver to the Procuring Agency a Performance Security (or Guarantee) in the amount and in the form stipulated in the <b>BDS and SCC</b> , denominated in the type and proportions of currencies in the Letter of Acceptance and in accordance with the Conditions of Contract.
	<b>43.2</b>	<p>If the Performance Security (or Guarantee) is provided by the successful Bidder and it shall be in the form specified in the <b>BDS</b> which shall be in any of the following:</p> <ul style="list-style-type: none"> <li>a) A bank guarantee,</li> <li>b) an irrevocable letter of credit issued by a reputable bank, or in the form provided in the Bidding Documents or another form acceptable to the Procuring Agency; or</li> <li>c) A cash deposit receipt issued by any reputable scheduled bank of Pakistan.</li> <li>d) Performance Guarantee in the form of Insurance Guarantee issued by an Insurance firm having AA rating</li> </ul> <p>The cost of complying with the requirements of this Sub-Clause shall be borne by the Supplier.</p> <p>The Performance Guarantee must be submitted in favor of the following:</p> <p><b>Chief Engineer (AM) North, NTDC Lahore</b>  <b>34-Industrial Area Gulberg-III, Lahore.</b></p>
	<b>43.3</b>	Failure of the successful Bidder to comply with the requirement of <b>ITB 43.1</b> shall constitute sufficient grounds for the annulment of the award and forfeiture of the Bid Security, in which event the Procuring Agency may make the award to the next ranked Bidder or call for new Bids.
<b>44. Advance Payment</b>	<b>44.1</b>	The advance payment will not be provided in normal circumstances. However, in case where international incoterms are involved, the same will be dealt with standard international practices and in the manner as prescribed in ITB 44.2. (Not Applicable)
	<b>44.2</b>	The Procuring Agency will provide an Advance Payment as stipulated in the Conditions of Contract, subject to a maximum

		amount, as stated in the <b>BDS</b> . The Advance Payment request shall be accompanied by an Advance Payment Security (Guarantee) in the form provided in Section IX. For the purpose of receiving the Advance Payment, the Bidder shall make and estimate of, and include in its Bid, the expenses that will be incurred in order to commence Delivery of Goods. These expenses will relate to the purchase of equipment, machinery, materials, and on the engagement of labor during the first month beginning with the date of the Procuring Agency's "Notice to Commence" as specified in the <b>SCC</b> . (Not Applicable)
<b>45. Arbitrator</b>	<b>45.1</b>	The Arbitrator shall be appointed by mutual consent of the both parties as per the provisions specified in the <b>SCC</b> .
<b>46. Corrupt &amp; Fraudulent Practices</b>	<b>46.1</b>	Procuring Agencies (including beneficiaries of Government funded projects and procurement) as well as Bidders/Suppliers/Contractors under Government financed contracts, observe the highest standard of ethics during the procurement and execution of such contracts, and will avoid to engage in any corrupt and fraudulent practices.

#### **F. GRIEVANCE REDRESSAL & COMPLAINT REVIEW MECHANISM**

<b>47. Constitution of Grievance Redressal</b>	<b>47.1</b>	Procuring agency shall constitute a Grievance Redressal Committee (GRC) comprising of odd number of person with proper power and authorization to address the complaint. The GRC shall not have any of the members of Procurement Evaluation Committee. The committee must have one subject specialist depending the nature of the procurement. (As per provisions of E-PADS)
<b>48. GRC Procedure</b>	<b>48.1</b>	Any party can file its written complaint against the eligibility parameters or any other terms and conditions prescribed in the prequalification or bidding documents found contrary to provision of Procurement Regulatory Framework, and the same shall be addressed by the GRC well before the bid submission deadline. (As per provisions of E-PADS)

	<b>48.2</b>	Any Bidder feeling aggrieved by any act of the procuring agency after the submission of his bid may lodge a written complaint concerning his grievances not later than seven days of the announcement of technical evaluation report and five days after issuance of final evaluation report. (As per provisions of E-PADS)
	<b>48.3</b>	In case, the complaint is filed against the technical evaluation report, the GRC shall suspend the procurement proceedings.
	<b>48.4</b>	In case, the complaint is filed after the issuance of the final evaluation report, the complainant cannot raise any objection on technical evaluation of the report:  Provided that the complainant may raise the objection on any part of the final evaluation report in case where single stage one envelop bidding procedure is adopted.
	<b>48.5</b>	The GRC, in both the cases shall investigate and decide upon the complaint within ten days of its receipt.
	<b>48.6</b>	Any bidder or the procuring agency not satisfied with the decision of the GRC may file Appeal before the Appellate Committee of the Authority on prescribed format after depositing the Prescribed fee.
	<b>48.7</b>	The Committee, upon receipt of the Appeal against the decision of the GRC complete in all respect shall serve notices in writing upon all the parties to Appeal.
	<b>48.8</b>	The committee shall call the record from the concerned procuring agency or the GRC as the case may be, and the same shall be provided within prescribed time.
	<b>48.9</b>	The committee may after examination of the relevant record and hearing all the concerned parties, shall decide the complaint within fifteen (15) days of receipt of the Appeal.
	<b>48.10</b>	The decision of the Committee shall be in writing and shall be signed by the Head and each Member of the Committee. The decision of the committee shall be final.

**G. MECHANISM OF BLACKLISTING**

<b>49. Mechanism of Blacklisting</b>	<b>49.1</b>	<p>The Procuring Agency shall bar for not more than the time prescribed in Rule-19 of the Public Procurement Rules, 2004, from participating in their respective procurement proceedings, bidder or contractor who either:</p> <ul style="list-style-type: none"> <li>i. Involved in corrupt and fraudulent practices as defined in Rule-2 of Public Procurement Rules;</li> <li>ii. Fails to perform his contractual obligations; and</li> <li>iii. Fails to abide by the bid securing declaration;</li> </ul>
	<b>49.2</b>	<p>The show cause notice shall contain: (a) precise allegation, against the bidder or contractor; (b) the maximum period for which the Procuring Agency proposes to debar the bidder or contractor from participating in any public procurement of the Procuring Agency; and (c) the statement, if needed, about the intention of the Procuring Agency to make a request to the Authority for debarring the bidder or contractor from participating in public procurements of all the procuring agencies.</p>

	<b>49.3</b>	The procuring agency shall give minimum of seven days to the bidder or contractor for submission of written reply of the show cause notice
	<b>49.4</b>	In case, the bidder or contractor fails to submit written reply within the requisite time, the Procuring Agency may issue notice for personal hearing to the bidder or contractor/ authorize representative of the bidder or contractor and the procuring agency shall decide the matter on the basis of available record and personal hearing, if availed.
	<b>49.5</b>	In case the bidder or contractor submits written reply of the show cause notice, the Procuring Agency may decide to file the matter or direct issuance of a notice to the bidder or contractor for personal hearing.
	<b>49.6</b>	The Procuring Agency shall give minimum of seven days to the bidder or contractor for appearance before the specified officer of the Procuring Agency for personal hearing. The specified officer shall decide the matter on the basis of the available record and personal hearing of the bidder or contractor, if availed
	<b>49.7</b>	The procuring Agency shall decide the matter within fifteen days from the date of personal hearing unless the personal hearing is adjourned to a next date and in such an eventuality, the period of personal hearing shall be reckoned from the last date of personal hearing.
	<b>49.8</b>	The Procuring Agency shall communicate to the bidder or contractor the order of debaring the bidder or contractor from participating in any public procurement with a statement that the bidder or contractor may, within thirty days, prefer a representation against the order before the Authority.
	<b>49.9</b>	Such blacklisting or barring action shall be communicated by the procuring agency to the Authority and respective bidder or bidders in the form of decision containing the grounds for such action. The same shall be publicized by the Authority after examining the record whether the procedure defined in blacklisting and debarment mechanism has been adhered to by the procuring agency.

	<b>49.10</b>	The bidder may file the review petition before the Review Petition Committee Authority within thirty days of communication of such blacklisting or barring action after depositing the prescribed fee and in accordance with “Procedure of filing and disposal of review petition under Rule-19(3) Regulations, 2021”. The Committee shall evaluate the case and decide within ninety days of filing of review petition
	<b>49.11</b>	The committee shall serve a notice in writing upon all respondent of the review petition. The notices shall be accompanied by the copies of review petition and all attached documents of the review petition including the decision of the procuring agency. The parties may file written statements along with essential documents in support of their contentions. The Committee may pass such order on the representation may deem fit.
	<b>49.12</b>	The Authority on the basis of decision made by the committee either may debar a bidder or contractor from participating in any public procurement process of all or some of the procuring agencies for such period as the deemed appropriate or acquit the bidder from the allegations. The decision of the Authority shall be final.

## **SECTION III: BID DATA SHEET**

***Bid Data Sheet (BDS)***

The following specific data for the goods to be procured shall complement, supplement, or amend the provisions in the Instructions to Bidders (ITBs). Whenever there is a conflict, the provisions herein shall prevail over those in ITBs.

<b>BDS Clause Number</b>	<b>ITB Number</b>	<b>Amendments of, and Supplements to, Clauses in the Instruction to Bidders</b>						
<b>A. Introduction</b>								
<b>1.</b>	<b>1.1</b>	<p><b>Name of Procuring Agency:</b> National Grid Company of Pakistan Limited (NGC)</p> <p><b>Address:</b> Chief Engineer (AM) North, NGC, NTDC House, 34-Industrial Area Gulberg-III, Lahore-Pakistan Telephone No. 92-42-99263023 Email: <a href="mailto:ce.amnl@ntdc.com.pk">ce.amnl@ntdc.com.pk</a></p> <p><b>THE SUBJECT OF PROCUREMENT IS:</b> PROCUREMENT OF UNIFORM ITEMS WITH ACCESSORIES/ LIVERIES FOR KEY POINT INSTALLATION (PHASE-I)</p> <table border="1"> <thead> <tr> <th><b>Sr. No.</b></th> <th><b>Description</b></th> <th><b>Qty (Nos.)</b></th> </tr> </thead> <tbody> <tr> <td>1.</td> <td>Procurement of Uniform Items with Accessories/ Liveries for Key Point Installation (Phase-I)</td> <td>As mentioned in BoQ</td> </tr> </tbody> </table> <p><b>Delivery Period:</b> 90 days</p> <p><b>Commencement date for delivery of Goods:</b> 14 days from issuance of Notification of Award or Date of Signing/ Acceptance of NOA whichever is earlier.</p> <p><i>Note: In case of delay in signing of the contract agreement due to late submission of Performance Guarantee or contract form, the delay shall be deductible from the period of delivery of goods. The Procuring Agency shall notify such delay while issuing commencement date of delivery.</i></p>	<b>Sr. No.</b>	<b>Description</b>	<b>Qty (Nos.)</b>	1.	Procurement of Uniform Items with Accessories/ Liveries for Key Point Installation (Phase-I)	As mentioned in BoQ
<b>Sr. No.</b>	<b>Description</b>	<b>Qty (Nos.)</b>						
1.	Procurement of Uniform Items with Accessories/ Liveries for Key Point Installation (Phase-I)	As mentioned in BoQ						
<b>2.</b>	<b>1.2</b>	<p>Add the following new sub-clause after Clause-1.1:</p> <p>i. Bidders shall submit a bid for complete scope of supply of as per Schedule of Prices.</p>						

		<p>ii. The Procuring Agency (PA) will award the Contract to the Bidder whose Bid is held the lowest evaluated substantially responsive Bid.</p> <p>iii. Bids for partial scope of supply shall be liable to rejection.</p> <p>iv. Transportation of Material:</p> <p>a. Goods supplied under this Contract will be transported by the Contractor from Ex-Works Pakistan to NGC designated warehouse/site at Contractor's own cost.</p>
3.	1.3	<p>Add the following new sub-clause after Clause-1.2:</p> <p>The Bidding is open on National Competitive Bidding (NCB) through Single Stage Two Envelope (1S2E) procedure.</p>
4.	2.1	<p><b>Financial year for the operations of the Procuring Agency:</b> 2025-26</p> <p><b>Name of Project:</b> PROCUREMENT OF UNIFORM ITEMS WITH ACCESSORIES/ LIVERIES FOR KEY POINT INSTALLATION (PHASE-I)</p> <p><b>Name of financing institution:</b> NGC Own Resources.</p> <p><b>Name and identification number of the Contract:</b> T-362(R)-2026.</p>
5.	3.1	<p>“any foreign country” may be replaced as “any foreign eligible country as stated in Section-IV of this Bidding Document.”</p> <p>Maximum number of members in the joint venture, consortium or association shall be: <b>Not more than 03 (Three).</b></p>
6.	3.2	<p>Add the following line at the end of Clause-3.2</p> <p>The Power of Attorney is to be signed by legally authorized signatories of all the joint venture partners.</p> <p>The partner-in-charge shall always be duly authorized to deal with the Procuring Agency regarding all matters related with and/or incidental to the supply of Goods as per the terms and Conditions of Contract and in this regard to incur any and all liabilities, receive instructions, give binding undertakings and receive payments on behalf of the joint venture.</p> <p>All partners of the joint venture shall at all times and under all circumstances be liable jointly and severally for the execution of the Contract in accordance with the Contract terms and a statement to this effect shall be included in the authorization mentioned above as well as in the Form of Bid and in the Form of Contract Agreement (in case of a successful bid).</p>

		<p>Written Power of Attorney, duly notarized, authorizing the signatory of the bid to act for and on behalf of the Bidder in the following manner:</p> <p>a) For foreign firm/bidder, board resolution and power of attorney (<b>duly attested by Consulate General of Pakistan/Pakistan Embassy</b>) are required. (Not Applicable)</p> <p>b) For local firm, board resolution and/or power of attorney provided on stamp paper worth Rs. 1000 or as per governing law, whichever is higher, are required.</p> <p>In case of non-submission or non-compliance of a valid power of Attorney, post bid clarification can be sought to submit same within fourteen (14) calendar days of receiving of such request and its failure may lead to rejection of the bid.</p>
7.	3.3	<p>Replace clause 3.3 with the following:</p> <p>The copy of the agreement entered into by the joint venture partners shall be submitted with the bid stating the conditions under which it will function, its period of duration, the persons authorized to represent and obligate it and which persons will be directly responsible for due performance of the Contract and can give valid receipts on behalf of the joint venture, the proportionate participation of the several firms forming the joint venture, and any other information necessary to permit a full appraisal of its functioning. No amendments / modifications whatsoever in the joint venture agreement shall be agreed to between the joint venture partners without prior written consent of the Procuring Agency.</p>

8.	3.5	<p>The following shall be added at the end of Clause-3.5:</p> <ul style="list-style-type: none"> <li>a) This Invitation for Bids is open to all Bidders having the nationality of Pakistan.</li> <li>b) The Bidder shall be manufacturer or Supplier legally registered for at least five (05) years. A copy of legal registration certificate shall be submitted along with the Bid.</li> <li>c) The local Bidder shall be registered with Income Tax and Sales Tax Departments and shall be on Active Taxpayers List of the Federal Board of Revenue.</li> <li>d) The Bidder/manufacturer shall not be blacklisted by NGC/WAPDA/DISCOs/any Government/Public department/Donor Agencies at the time of submission of bids. The Bidder/manufacturer should provide details of previous black listing, if any. An affidavit is to be provided by the Bidder/manufacturer that the Bidder/manufacturer is not black listed by NGC/WAPDA/DISCOs/any Government/Public department/Donor Agencies at the time of submission of bids.</li> <li>e) The bidder shall submit an unconditional “Comfort Letter” along with their bid as per Form-14R from a Scheduled Bank (the “Bank”) in Pakistan.</li> </ul>
9.	3.6	Not Applicable.
10.	3.11	Not Applicable.
11.	4.1	Ineligible Country stated in the Section-4 titled as “Eligible Countries”.
12.	4.2	<p>Add the following at the end of Clause-4.2</p> <p>For purposes of this Clause, the term “Goods” includes commodities, raw material, machinery, equipment, Tools &amp; Plant, and industrial plants.</p>
13.	4.5	Demonstration of authorization by manufacturer: <b>required.</b>

**B. Bidding Documents**

14.	7.1	<p>Following paragraph shall be added</p> <p>Volume-II</p> <ol style="list-style-type: none"> <li>1. NGC's SOP for Blacklisting of Contractors</li> <li>2. Specifications of Uniform Items/ Liveries</li> </ol>
15.	7.2	<p><b>The scanned copy of original bid (signed &amp; stamped) to be uploaded by bidder on E-PADS v2.0 before closing date &amp; time of bid submission.</b></p> <p>After the Award of Contract, the Supplier/Contractor will provide copies of 02 Nos. of Contract Agreement complete in all respect within ten (10) days from the signing of Contract Agreement.</p>
16.	8.1	<p>The address for clarification of Bidding Documents is:-</p> <p>Chief Engineer (AM) North, NGC, NTDC House, 34-Industrial Area Gulberg-III, Lahore-Pakistan Telephone No. 92-42-99263023 Email: <a href="mailto:ce.amnl@ntdc.com.pk">ce.amnl@ntdc.com.pk</a></p>
17.	8.2	<p>Replace the text of Clause-8.2 with the following:</p> <p>No request for clarification will be entertained which will be received later than 14 days prior to the date fixed for submission of Bids. The Procuring Agency's response will be made not later than 7 days prior to the date fixed for submission of Bids.</p> <p>Further, the mere request for clarification from the bidders shall not be a ground for seeking extension in the deadline for submission of Bids.</p>
18.	8.5	<p>There will be no Pre-Bid meeting, in any case.</p>

**C. Preparation of Bids**

19.	10.1	<p>The Language of all correspondences and documents related to the Bid is: English</p>
20.	11.1	<p>Delete the text of this Sub-Clause and substitute with the following:</p>

	<p>The Bid uploaded by the Bidder shall be prepared in two (02) parts, one including the “Technical Bid” and the other “Price Bid” comprising the following documents respectively. These parts are to be separately uploaded on E-PADS.</p> <p><b>i. “Technical Bid”</b></p> <p>Form 1A: Letter of Bid – Technical Proposal  Form 3: List of Related Services and Completion Schedule  Form 4: Delivery &amp; Completion Schedule  Form 5: Schedule of Shipping Weights &amp; Dimensions  Form 6: Manufacturer’s Authorization  Form 7: Specific Goods Data  Form 8: Deviations From Technical Provisions  Form 9: Deviations From Contractual Conditions  Form 10: Declaration of Local Agent  Form 11: List of Manufacturers/Subcontractors  Form 12: Foreign Currency Requirements (Not Used)  Form 13: Undertaking Of Acceptance of And Compliance with The Sop for Blacklisting of Contractors  Form 14A: Bidder Information Form  Form 14B: Bidder’s JV Members Information Form  Form 14C: General Information &amp; Evidence of Manufacturer’s Capability  Form 14D: Organization Chart  Form 14E: Manufacturer’s Experience of Supply Record  Form 14F: Performance Certificate-Summary of operational Experience  Form 14G: Current Contract Commitments  Form 14H: Financial Data  Form 14I: Annual Turnover Data  Form 14J: Bank Certificate  Form 14K: Financial Resources  Form 14L: Pending Litigation  Form 14M: Manufacturer’s Orders in Hand  Form 14N: Manufacturer’s Orders in Pipeline  Form 14O: Method of Assuring Quality of Goods  Form 14P: List of Quality Control/Laboratory Equipment  Form 14R: Comfort Letter  Form 16: Form of Bid Security</p> <p>In addition to the above forms, following documents/information shall be provided with the bid:</p>
--	---

		<p>ii. Written Power of Attorney, duly notarized, authorizing the signatory of the bid to act for and on behalf of the Bidder in the following manner:</p> <p>iii. For foreign firm/bidder, board resolution and power of attorney (<b>duly attested by Consulate General of Pakistan/Pakistan Embassy</b>) are required. (Not Applicable)</p> <p>iv. For local firm, board resolution and/or power of attorney provided on stamp paper worth Rs. 1000 or as per governing law, whichever is higher, are required.</p> <p>v. In case of non-submission or non-compliance of a valid power of Attorney, post bid clarification can be sought to submit same within fourteen (14) calendar days of receiving of such request and its failure may lead to rejection of the bid.</p> <p>vi. Legal Registration Certificate.</p> <p>vii. Copies of Documents defining the constitution or legal status, place of registration and principal place of business.</p> <p>viii. An affidavit that the Bidder has not been black listed by NGC/WAPDA/DISCOs/any Government/Public Department/Donor Agencies at the time of submission of bids.</p> <p>ix. Beneficial Ownership Declaration Performa dully filled by the Bidder as per S.R.O 592(I)/2022 available at <a href="https://www.ppra.org.pk/doc/sro592.pdf">https://www.ppra.org.pk/doc/sro592.pdf</a></p> <p>x. Quality confirmation certificate.</p> <p>xi. Electronic/Soft copy of complete Technical Bid in USB/Pen Drive containing an electronic version of the Bid in PDF format scanned from the original bid. The Scan form of Original Bid should be uploaded on E-PADS.</p> <p>ii. <b>“Price Bid”</b></p> <p>Form 1B: Letter/ Form of Bid – Financial Proposal</p> <p>Form 2A: Price Schedules for Goods and Related Services offered from Abroad (Not Applicable)</p> <p>Form 2B: Price Schedule: Goods Manufactured outside Pakistan, already imported</p> <p>Form 2C: Price Schedule for Domestic Goods Manufactured within Pakistan</p> <p>Form 14Q: Domestic Goods (Value added in Pakistan)</p>
--	--	--

		Further, Electronic/Soft copy of complete Financial Bid in USB/Pen Drive containing an electronic version of the Bid in PDF format scanned from the original bid. The soft copy should be uploaded on E-PADS.
21.	11.2	<b>Not Applicable.</b>
22.	11.3	<b>Not Applicable.</b>
23.	11.4	<b>Not Applicable.</b>
24.	11.5	<b>Not Applicable.</b>
25.	11.6	<b>Not Applicable.</b>
26.	12.3 (c)	Other procurement specific documentation requirements are: As per Section-V, Schedule of requirement, technical specifications.
27.	12.4	<b>Not Applicable.</b>
28.	13.3 (b) (i)	<p>Add the following Sub-clause in replacement of 13.3 (b)</p> <p>The qualification criteria required from Bidders in <b>ITB 13.3(b)</b> is modified as follows:</p> <p>To be qualified for award of a Lot, the Bidder shall meet the experience, capability and adequacy of resources as per criteria delineated herein below:</p> <ul style="list-style-type: none"> <li>• <b>Contract/Performance Requirements Experience</b></li> <li>• The Bidder must have successfully completed at least one (1) supply contract(s) regarding uniform items/ liveries/ similar material within the last ten (10) years having value of PKR 10 Million accumulatively. The Bidder shall submit with the bid evidence in this regard including interalia copies (with English translation) of the contract agreement(s) and completion certificate(s)/delivery document(s) (bills of lading, inspection certificates etc.) for the contract(s). In case of JV, all JV partners shall combinedly meet the said required experience.</li> <li>• The bidder shall have one (1) year of Operational Experience or accomplished period of 15 months after delivery of the similar (or higher rating) equipment/ material in case of NGC/DISCOs network whichever is less.</li> </ul> <p style="text-align: center;">(OR)</p>

		<ul style="list-style-type: none"> <li>• Three (3) years of operational experience for other networks. In this case, the bidder will have to furnish one operational certificate issued by the end user in favor of the manufacturer from outside its country.</li> <li>• The bidder shall also submit copies of contract agreements duly notarized (along with notarized translation in English if original is in different language) for these supplies. Further, the summary of operational experience shall be provided as per <b>Form 14F</b>.</li> <li>• <b>Supply Capacity</b></li> </ul> <p>The manufacturer shall provide the following information with the Bid to establish its capacity/capability to execute the order.</p> <ol style="list-style-type: none"> <li>a. Manufacturing Capacity</li> <li>b. Orders in hand</li> <li>c. Expected orders in pipe line</li> <li>d. Implementation schedule of the orders in hand</li> </ol> <p>The manufacturing capacity of the Bidder should be at least equal to orders in hand, expected orders in pipeline and this order (if placed on it).</p> <ul style="list-style-type: none"> <li>• <b>Type Testing</b></li> </ul> <p>The Goods offered by the Bidder shall be type tested in accordance with Section-V “Schedule of Requirements, Technical Specifications” of the Bidding Documents. In case of non-submission of type test reports with the Bid or not meeting the requirements given in Section-V “Schedule of Requirements, Technical Specifications” of the Bidding Documents the Bid shall be rejected by the Procuring Agency and bidder shall be declared as non-responsive. (Not Applicable)</p> <p>Note: This provision/requirement is required to be fulfilled by all manufacturers including local JV partners or local subsidiaries of international manufactures.</p>
--	--	--

		<ul style="list-style-type: none"> <li> <b>Financial Criteria</b> </li> </ul> <p>The Procuring Agency (PA) will take into account the following criteria to verify the financial qualification of the Bidder.</p> <ul style="list-style-type: none"> <li>                     The audited Financial “Standalone” Statements (Balance Sheet along with Notes, Profit &amp; Loss Accounts and Cash Flow Statement) audited by Chartered Accountant for the last three (03) years shall be submitted by the Bidder. The audited Financial Report issued for year 2024 and onwards should have UDIN as per ICAP letter circular No. 12/2024 dated 12.09.2024. The Bidder’s Financial Statements for the last one year of the audited accounts should show that it has positive “NET WORTH” calculated as a difference between total assets and total liabilities (<b>Information to be submitted in Form 14H</b>). In case of JV, each JV partner shall meet the aforementioned criteria.                 </li> <li>                     The Bidder’s Income &amp; Expenditure / Profit and Loss Accounts should show minimum average annual turnover for the best three years out of last five years not less than                     <table border="1" data-bbox="691 1187 1385 1476"> <thead> <tr> <th data-bbox="691 1187 770 1348">Sr. No.</th> <th data-bbox="770 1187 1217 1348">Description</th> <th data-bbox="1217 1187 1385 1348">Average Annual Turnover (PKR)</th> </tr> </thead> <tbody> <tr> <td data-bbox="691 1348 770 1476">1.</td> <td data-bbox="770 1348 1217 1476">Procurement of Uniform Items with Accessories/ Liveries for Key Point Installation (Phase-I)</td> <td data-bbox="1217 1348 1385 1476">13 million</td> </tr> </tbody> </table> </li> </ul> <p><b>(Information to be submitted in Form 14I. The audited statements for the last five years shall be appended with the bid.)</b></p> <p>In case of JV, all the JV partners shall combined/collectively meet the requisite criteria with the lead partner and other partner(s) meeting not less than 40% and 25% respectively of the said criteria.</p> <ul style="list-style-type: none"> <li>                     The Bidder must demonstrate access to, or availability of, financial resources such as liquid assets, lines of credit, and other financial means, net of current commitments, to meet the total cash flow requirements equaling following amounts for evaluation purpose:                 </li> </ul>	Sr. No.	Description	Average Annual Turnover (PKR)	1.	Procurement of Uniform Items with Accessories/ Liveries for Key Point Installation (Phase-I)	13 million
Sr. No.	Description	Average Annual Turnover (PKR)						
1.	Procurement of Uniform Items with Accessories/ Liveries for Key Point Installation (Phase-I)	13 million						

Sr. No.	Description	Financial Resources (PKR)
1.	Procurement of Uniform Items with Accessories/ Liveries for Key Point Installation (Phase-I)	6.5 million

**(Information to be submitted in Form 14J & 14K).**

In case of JV, all the JV partners shall combined/collectively meet the requisite criteria with the lead partner and other partner(s) meeting not less than 40% and 25% respectively of the said criteria.

**Note:**

- A new local subsidiary of an international manufacturer (Registered/pre-qualified as per NGC's Sop for placement of Educational Orders) can meet the Contract experience, operational experience and financial requirements on the basis of his parent Company's experience, bank statements, resources etc. subject to provision of an undertaking for support in execution of the order from parent Company. The parent company will further undertake that it will be responsible for execution of order in case of default of the local subsidiary.
- No credit line shall be acceptable after date of bid opening. Any withdrawal of the credit lines (if submitted) from the bidder's creditors during validity period will be considered a withdrawal of bid.

- **Litigation History**

Bidders are requested to submit details of all litigation, arbitration and other claims whether pending, threatened or resolved in the last five (05) years. The Procuring Agency (PA) may disqualify the Bidder in the event that the total amount of pending or threatened litigation, arbitration or other claims represents twenty-five percent (25%) of the Bidder's net worth. Details in this regard should be submitted in the prescribed format given in **Form 14L**.

The Bidder is required to include with its Bid, documentation from the manufacturer of the goods, that it has been duly

		authorized to deliver, in Pakistan, the goods indicated in its Bid.
		<p>The Qualification of the Bidders will be based on meeting the pass/fail criteria as demonstrated by the Bidders' responses in the respective Forms.</p> <p>The above stated requirements are the minimum and the Procuring Agency reserves the right to request for any additional information. The Procuring Agency also reserves the right to reject the proposal of any Bidder, if in the opinion of the Procuring Agency the qualification details are incomplete, ambiguous or the Bidder is found not qualified to satisfactorily perform the Contract.</p> <p>The above stated Forms should be completed as per prescribed format and submitted along with required attachments. The missing or incomplete information/documents may render the bid substantially non-responsive. In this regard, the Procuring Agency does not have an obligation to request any document/certificates.</p>
29.	13.3(c)	The Bidder shall submit Declaration of Local Agent, if any, as per <b>Form-10</b> .
30.	14.1	<p>Add the following at the end of Clause 14.1</p> <p>All blank spaces shall be filled in with the information requested.</p>
31.	15.6 (a))(ii)	Ex-works price shall inclusive of all taxes and duties except Sales Tax which will be dealt pursuant to SCC Clause-43 of Section-VIII: Special Conditions of Contract. (Not Applicable)
32.	15.7 (a) (iii), (iv) (optional)	Material against the Contract will be provided by the successful bidder on FCS Basis.
33.	15.7 (a) (i) & 15.6 (b) (i) (ii), (iii) (optional) (iv), (v) (optional)	<p>For goods offered by the supplier/ bidder, the price quoted shall be:</p> <p><b>FCS Basis, A-Type Store NKLP Lahore.</b></p>
34.	15.8	The price shall be fixed.
35.	16.1	Replace the text of Clause 16.1 with the following:

		<p>The Bidders shall quote the unit rates and prices in Pak Rupees. The Bidders shall be paid as per quoted currency (ies).</p> <p>Notwithstanding the above, the Pakistani Bidders expecting to incur portion of expenditures in foreign currency for import of raw materials for offering Goods from within the Procuring Agency's country on Ex-Works Pakistan basis may quote corresponding portion of its Bid Price in any freely convertible currency in the Schedule of Prices. However, Local Bidders are not allowed to quote on CIF/C&amp;F Karachi Basis. They shall quote only on Ex-works Basis. (Not Applicable)</p> <p>The payment to Pakistani Bidders, in the above case, will be made in equivalent Pak Rupees calculated by using exchange rate prevailing at the date of Bill of Entry of the imported raw materials for supplying Goods on Ex-Works Pakistan basis. The Bill of Entry of the imported raw material shall fall within the Scheduled Delivery Period. Moreover, Bill of Entry issued after Scheduled Delivery Period resulting depreciation in the currency will be on Contractor's part and NGC will recover the same from Contractor's Invoice. The prevalent exchange rate shall be Telegraphic Transfer and On Demand (TT&amp;OD) composite exchange rate (selling) published by National Bank of Pakistan. (Not Applicable)</p>						
<b>36.</b>	<b>16.2</b>	<p>Replace the text of Clause 16.2 with the following:</p> <p>For the purposes of comparison of bids quoted in different currencies, the price shall be converted into a single currency specified in the bidding documents. The rate of exchange shall be the selling rate, prevailing on the date of opening of bids specified in the bidding documents, as notified by National Bank of Pakistan on that day. (Not Applicable)</p>						
<b>37.</b>	<b>17.1</b>	The Bid Validity period shall be minimum <b>180 days</b> from the date of opening of bids through E-PADS.						
<b>38.</b>	<b>17.3</b>	Not Applicable						
<b>39.</b>	<b>18.1</b>	<p>The amount of Bid Security shall be</p> <table border="1"> <thead> <tr> <th><b>Sr. No.</b></th> <th><b>Description</b></th> <th><b>Bid Security (PKR)</b></th> </tr> </thead> <tbody> <tr> <td>1.</td> <td>Procurement of Uniform Items with Accessories/ Liveries for Key Point Installation (Phase-I)</td> <td>400,000/-</td> </tr> </tbody> </table>	<b>Sr. No.</b>	<b>Description</b>	<b>Bid Security (PKR)</b>	1.	Procurement of Uniform Items with Accessories/ Liveries for Key Point Installation (Phase-I)	400,000/-
<b>Sr. No.</b>	<b>Description</b>	<b>Bid Security (PKR)</b>						
1.	Procurement of Uniform Items with Accessories/ Liveries for Key Point Installation (Phase-I)	400,000/-						

		<p>The currency of the Bid Security shall be: PKR</p> <p><b>The Bid Security must be submitted in original, in favor of “Chief Engineer (AM) North, NTDC Lahore” in the office of Chief Engineer (AM) North, NGC Lahore, before the closing date and time of bid submission on E-PADS.</b></p> <p>The bid security amount in any other currency shall be converted to equivalent PKR using the Telegraphic Transfer and On Demand (TT&amp;OD) composite exchange rates (selling) published by National Bank of Pakistan prevailing on the date of the opening of Bids). (Not Applicable)</p>
40.	18.3	<p>The clause may be deleted and replaced as under:</p> <p>The Bid Security shall be, at the option of the Bidder, in the form of Deposit at Call (CDR, Pay Order or <b>Banker’s</b> Cheque) or in the form of <b>Bid Security</b> issued by a Scheduled Bank in Pakistan in favor of the below mentioned officer, on the prescribed Form annexed to these Documents valid for a period 28 days beyond the Bid Validity date.</p> <p><b>Chief Engineer (AM) North, NTDC Lahore 34-Industrial Area Gulberg-III, Lahore.</b></p> <p>The Bid Security of Joint Venture shall be in the name of Joint Venture submitting the Bid. JV may authorize any of its member to submit bid security. However, it will be clearly mentioned that Bid Security is submitted on behalf of JV.</p> <p>For avoidance of doubt, a Bid Security issued by a foreign bank but not counter guaranteed by a Scheduled Bank in Pakistan [<i>or a counter guarantee which impacts rights of Employer to encash the Guarantee on 1<sup>st</sup> written notice from Bank in Pakistan</i>] shall not be acceptable and rejected as non-responsive. (Not Applicable)</p> <p>[Any mode for submission of bid security apart from aforementioned like Swift Code or Crossed Cheque will not be acceptable]</p>
41.	18.9 (a) (iii)	<p>The following sub-clause is added after Clause 18.9 (a) (ii):</p> <p>The Bid Securities of the Bidder(s) found involved in corrupt and fraudulent practices, shall be forfeited.</p>
42.	18.10	<p>The following clause is added after Clause 18.9:</p>

		<p>A bid must be accompanied by an acceptable Bid Security that is unconditional, irrevocable and callable. If a bidder submits a Bid Security that has following discrepancies (to the extent mentioned against each), the Procuring Agency shall request the Bidder to submit a complaint bid security within fourteen (14) days of receiving such request. Failure to provide a complaint bid security within the prescribed period of receiving such a request shall cause the rejection of the bid. Any bid accompanied by bid security with deviation greater than the extent mentioned below shall be rejected:</p> <ul style="list-style-type: none"> <li>i. Bid Security amount is short within 10% of Bid Security amount; and/or</li> <li>ii. Bid Security validity period is short by a maximum of two days</li> <li>iii. Any changes with respect to format/text which does not hurt the right of employer for encashment of the guarantee and does not limit the obligation of the bidder as required in the Bidding Document/Bid Security Format.</li> </ul>
<b>43.</b>	<b>19.1</b>	Alternative Bids to the requirements of the Bidding Documents will not be permitted.
<b>44.</b>	<b>20.3</b>	<p>The following clause shall be added after 20.2</p> <ul style="list-style-type: none"> <li>i. The modification, substitution, or notice for withdrawal of any bid shall be prepared, sealed, marked and delivered in accordance with the provisions of Clause-22 of Section-II: Instruction to Bidders with the outer and inner envelopes additionally marked “MODIFICATION”, “SUBSTITUTION” or “WITHDRAWAL” as appropriate. (as per provision of E-PADS)</li> <li>ii. No bid may be modified by a Bidder after the deadline for submission of bids except in accordance with ITB Sub-Clauses 20.1 and 31.2. (as per provision of E-PADS)</li> <li>iii. Withdrawal of a bid during the interval between the deadline for submission of bids and the expiration of the period of bid validity specified in the Form of Bid may result in forfeiture of the Bid Security. (as per provision of E-PADS)</li> </ul>
<b>45.</b>	<b>21.1</b>	The Bidder shall upload Electronic/Soft copy of complete Technical Bid containing an electronic version of the Bid in PDF format scanned from the original signed bid. The scanned

		<p>form of this technical bid will be uploaded by bidder on E-PADS.</p> <p>The Bidder shall submit Electronic/Soft copy of complete Price Bid in USB/Pen Drive containing an electronic version of the Bid (Price Schedules) in MS Office (Excel) format. The scanned signed form of this financial bid will be uploaded by bidder on E-PADS.</p>
46.	21.2	<p>The authorization shall be in the form of written Power of Attorney and it will be duly notarized, authorizing the signatory(ies) of the bid to act for and on behalf of the Bidder in the following manner:</p> <ol style="list-style-type: none"> <li>a) For foreign firm/bidder, board resolution and power of attorney (duly attested by Consulate General of Pakistan/Pakistan Embassy) are required. (Not Applicable)</li> <li>b) For local firm, board resolution and/or power of attorney provided on stamp paper worth Rs. 1000 or as per governing law, whichever is higher, are required.</li> <li>c) In case of non-submission or non-compliance of a valid power of Attorney, post bid clarification can be sought to submit same within fourteen (14) calendar days of receiving of such request and its failure may lead to rejection of the bid.</li> </ol>

#### D. Submission of Bids

47.	22.2 (a)	<p>Bid (Technical &amp; Financial Proposals) shall be uploaded to E-PADS v2.0 in their respective sections before the closing date and time of bid submission. The bids will be opened through E-PADS only.</p> <p><b>Note:</b>  <b>The non-returnable samples of each uniform item/ accessory mentioned in BoQ must be provided by bidder to NGC, before the date &amp; time of submission of bids on E-PADS v2.0. The non-submission of samples may result in the rejection of respective bid.</b></p>
48.	22.2 (b)	<p>Title of the subject: PROCUREMENT OF UNIFORM ITEMS WITH ACCESSORIES/ LIVERIES FOR KEY POINT INSTALLATION (PHASE-I)</p> <p>ITB Title and No: T-362(R)-2026</p>

		Deadline for submission of Bids on E-PADS v2.0: <b>Date: 18.05.2026</b> <b>Time: 11:00 hrs</b>
49.	22.4 (b)	Replace 22.4 (b) with the following:  Bear the name and identification number of the contract as defined in the Bidding Data and the outer envelopes and the inner envelopes containing the Technical Bid shall bear a warning not to open before the time and date for the opening of Technical Bids, in accordance with ITB 23.1. The envelopes containing the Price Bid shall bear a warning not to open until advised by the Procuring Agency in accordance with ITB 26.6. (Not Applicable)
50.	23.1	The deadline for Bid uploading is <b>Date: 18.05.2026</b> <b>Time: 11:00 hrs</b>

#### E. Opening and Evaluation of Bids

51.	26.1	The Bid opening on E-PADS shall take place at:  Street address: <b>34-Industrial Area Gurumangat Road</b> Building/Plot No. <b>Office of Chief Engineer (AM) North, NTDC House Gulberg-III</b> Floor/Room No: <b>1<sup>st</sup> Floor</b> City/Town: <b>Lahore</b> Country: <b>Pakistan</b> <b>Day : Monday</b> <b>Date: 18.05.2026</b> <b>Time : 11:30 hrs</b>
52.	27.4	Add the following sub-clause after 27.3  Bidders and their respective agents, manufacturers/suppliers, representatives and anyone else on behalf of the Bidder will not unsolicited communicate or attempt to communicate directly or indirectly with the Procuring Agency including its employees, directors, officers or representatives during any part of the Competitive Bidding Process, except as expressly directed or permitted by the Procuring Agency.  Bidders will also not engage in any form of political or other lobbying whatsoever with respect to their Bids, or otherwise attempt to influence the outcome of the Competitive Bidding Process. In the event of any such communications or lobbying,

		<p>Procuring Agency may at any time reject the Bid submitted by that Bidder without further consideration.</p> <p>Further, Anonymous Communications will invariably be destroyed by their recipient and no action of any kind will be taken on them, nor any notice be taken of their contents.</p>
53..	28.5	<p>Add the following sub-clause after 28.4</p> <p>If a Bidder does not provide clarifications of its Bid by the date and time set in the Procuring Agency's request for clarification, its Bid may be rejected.</p>
54.	31.1	<p>Add the following after 31.1 (d)</p> <p>(e) If there is discrepancy between the quantities of item mentioned in the Bidding Document and quoted by the Supplier/Contractor in his bid, the quantity mentioned in the Bidding/Tender Document shall prevail and total price shall be corrected accordingly.</p>
55.	32.2	<p>The currency that shall be used for Bid evaluation and comparison purposes to convert all Bid prices expressed in various currencies is: <b>PKR</b></p>
56.	33.5	<p>The clause may be deleted and replaced as under:</p> <p>In evaluating the Bidders, the evaluation committee will, in addition to the Bid price quoted in accordance with BDS Clause-35, take account of one or more of the following factors and quantified hereunder:</p> <p>Following evaluation methods for price adjustments will be followed:</p> <ol style="list-style-type: none"> <li>i. Price Adjustment for Technical Compliance</li> <li>ii. Price Adjustment for Commercial Compliance.</li> <li>iii. Price Adjustment for Deviation in Terms of Payment.</li> <li>iv. Price Adjustment for deviation in delivery schedule.</li> <li>v. Price Adjustment for Capitalization of Transformer/Shunt Reactor/Capacitor Losses and Battery Types (whichever is applicable.)</li> </ol> <p><b>(i) Price Adjustment for Technical Compliance</b></p> <p>The cost of making good any deficiency resulting from technical non-compliance will be added to the Corrected Total Bid Price for comparison purposes only. The adjustments will be applied taking the highest price quoted by other Bidders</p>

		<p>being evaluated in detail in their original Bids for corresponding item. In case of non-availability of price from other Bidders, the price will be estimated.</p> <p><b>(ii) Price Adjustment for Commercial Compliance</b></p> <p>The cost of making good any deficiency resulting from any quantifiable variations and deviations from the Bid Schedules and Conditions of Contract, as determined will be added to the Corrected Total Bid Price for comparison purpose only. Adjustment for commercial compliance will be based on Corrected Total Bid Prices.</p> <p><b>(iii) Price Adjustment for Deviation in Terms of Payment</b></p> <p>If a bid deviates from the terms of payment/payment conditions as specified in the Conditions of Contract and if such deviation is considered acceptable to the Procuring Agency, mark-up earned for any earlier payments involved in the terms outlined in the Bid as compared to those stipulated in the Conditions of Contract shall be calculated at the following mark-up rates:</p> <ul style="list-style-type: none"><li>- for foreign currency component: 8% per annum (Not Applicable)</li><li>- for local currency component: KIBOR + 4.5% per annum</li></ul> <p>And shall be added to the Corrected Total Bid Price for comparison purposes only.</p> <p><b>(iv) Price adjustment for deviation in delivery schedule</b></p> <p>For Bids indicating delivery before specified days set out in Form-4 of Section-VI: Standard Forms, no credit will be given in this evaluation.</p> <p>Bids indicating delivery later than specified days set out in Form-4 of Section-VI: Standard Forms shall be adjusted in this evaluation by adding a factor of 0.05% of the Discounted Corrected Total Bid Price for each Calendar Day of the delivery later than the specified days. Bids indicating delivery beyond 30 days later than specified days set out in Form-4 of Section-VI: Standard Forms shall not be considered and rejected as non-responsive.</p>
--	--	--

		<p><b>(v) Price Adjustment for Capitalization of Transformer/Shunt Reactor/ Capacitor Losses and Battery Types (whichever is applicable)</b></p> <p>Price Adjustment for Capitalization of Transformer/Shunt Reactor/Capacitor Losses and Battery Types (whichever is applicable) will be made in accordance with the relevant <b>provisions of Specifications-Technical Provisions</b> or elsewhere of the Bidding Documents.</p>
57.	33.6	In case of award to a single Bidder of multiple lots; the methodology of evaluation to determine the lowest evaluated Lot combinations, including any discounts offered in the Form of Bid is <b>Cross Discount</b> .
58.	34.1	<p>In the comparison of evaluated Bids, Goods manufactured/produced in Pakistan shall be granted a margin of preference in accordance with the following procedure: (Not Applicable)</p> <p>1. Price preference for the Goods manufactured/produced in Pakistan shall be allowed as under: -</p> <p>(a) Having minimum of twenty percent (20%) value addition through indigenous manufacturing, price preference shall be fifteen percent (15%);</p> <p>(b) Having over twenty percent (20%) and up to thirty percent (30%) value addition through indigenous manufacturing, price preference shall be twenty percent (20%); and</p> <p>(c) Having over thirty percent (30%) value addition through indigenous manufacturing, price preference shall be twenty-five percent (25%).</p> <p>Bidders applying for the preference shall provide all evidence in Form-14Q to Bidding Data necessary to prove that the Goods offered by them are manufactured in Pakistan and the manufacturing cost of such Goods includes a value addition through indigenous manufacturing in accordance to the percentage as mentioned above of the FCS Bid price of the Goods. The bidder shall also present the certificate issued by Engineering Development Board (EDB) in this respect.</p>

		<p>2. For the purpose of granting of margin of domestic preference, all responsive Bids will first be classified into following three categories: -</p> <p>CATEGORY-I: Bids offering Goods manufactured in Pakistan which meet minimum of twenty percent (20%) value addition through indigenous manufacturing;</p> <p>CATEGORY-II: Bids offering Goods manufactured in Pakistan with value addition through indigenous manufacturing less than 20%; and</p> <p>CATEGORY-III: Bids offering imported Goods.</p> <p>The Procuring Agency will review each Bid to confirm the appropriateness of, or to modify as necessary, the category to which the Bid was assigned by the Bidder in preparing it.</p> <p>3. The lowest evaluated Bid of each category will then be determined by comparing all evaluated Bids in each Category among themselves without taking into account custom duties&amp; other import charges, sales tax and local body charges levied in connection with the sale or delivery, pursuant to the Bids, of the Goods.</p> <p>4. Such lowest evaluated Bids shall next be compared with each other. For this purpose, landed cost of the lowest evaluated Bids from each Category will be computed as per attached Annex-1 to Bidding Data using the Telegraphic Transfer and On Demand (TT&amp;OD) composite exchange rates (selling) published by National Bank of Pakistan prevailing on the date of the opening of Bids. The comparison of Bids shall then be made with respect to the landed cost of the Goods. If as a result of this comparison, a Bid from Category-I or Category-II is found to be the lowest, it will be selected for the award of Contract.</p> <p>5. If, however, as result of the comparison, under paragraph (4) above the lowest evaluated Bid is found to be from Category-III, its landed cost will be further compared with the landed cost of lowest evaluated Bid from Category-I by</p>
--	--	--

		<p>applying applicable price preference. For the purpose of this further comparison only, a downward price adjustment will be made to the lowest evaluated Bid price of Category-I by reducing its landed cost by applicable price preference i.e. 15%, 20% &amp; 25% of the landed cost of the lowest evaluated Bid from Category-III in Equivalent Pak Rupees. However, such price preference will be allowed provided that:</p> <p>a) Saving in foreign exchange is not less than amount of applicable price preference. This will be worked out as difference of foreign component of Bid Price of lowest evaluated Bid from Category III and foreign component of Bid Price of lowest evaluated Bid from Category I as per the total import requirements stated in Para b) here below.</p> <p>b) The total import requirements for locally manufacturing the Goods for which price preference had been applied, have been duly substantiated by the Bidder.</p> <p>If after such comparison, the Category-I Bid is determined to be the lowest, it will be selected for the award of Contract, if not, lowest evaluated Bid from Category-III will be selected for award.</p> <p>6. The above procedure for margin of preference including computation of Landed Cost is subject to change as per policy of the Federal Government as applicable on the date of Bid opening.</p>
59.	35.1	<p><b>Evaluation Techniques</b></p> <p><b>Least Cost Based Selection (LCBS)</b> After meeting the requirements of eligibility, qualification and substantial responsiveness, the bid in compliance with all the mandatory (technical) specifications/requirements and/or requisite quality threshold (if any), and having lowest evaluated cost (or financial proposal) shall be considered highest ranked bid.</p>
60.	35.2	Not Applicable

<b>F. Award of Contract</b>		
<b>61.</b>	<b>40.1</b>	Percentage of increase or decrease in the quantity of Goods shall not exceed 15%.  <b>This increase or decrease in quantity is different than Repeat Order which can be placed after award of contract.</b>
<b>62.</b>	<b>43.1</b>	The Performance Security (or guarantee) shall be <b>10 percent of the Contract Price.</b>
<b>63.</b>	<b>43.2</b>	Delete 43.2 (b), (c), (d) and replace it with the following:  The Supplier shall provide a Performance Security in the prescribed Form annexed to these Documents in the form of Guarantee from any Scheduled Bank in Pakistan The cost of complying with the requirements of this Sub-Clause shall be borne by the Supplier/ bidder.
<b>64.</b>	<b>44.1</b>	<b>Not Applicable.</b>
<b>65.</b>	<b>44.2</b>	<b>Not Applicable.</b>
<b>66.</b>	<b>44.3</b>	Add the following sub-clause after Clause-44.2  The Advance Payment Guarantee shall be progressively reduced by the amount paid by the Supplier as indicated in Interim Payment Certificates issued in accordance with this Clause. (Not Applicable)  The advance payment shall not be subject to retention.
<b>67.</b>	<b>45.1</b>	Arbitrator shall be appointed by mutual consent of the both parties.
<b>68.</b>	<b>46.1</b>	Add the following at the end of Clause 46.1  For the purposes of this provision, the term “Corrupt and Fraudulent Practices” includes the offering, giving, receiving, or soliciting of anything of value to influence the action of a public official or the supplier or contractor in the procurement process or in contract execution to the detriment of the procuring agencies; or misrepresentation of facts in order to influence a procurement process or the execution of a contract, collusive practices among bidders (prior to or after bid submission) designed to establish bid prices at artificial, non-competitive levels and to deprive the procuring agencies of the benefits of free and open competition and any request for, or solicitation of anything of value by any public official in the course of the exercise of his duty.

**G. Review of Procurement Decisions**

<b>69.</b>	<b>49.1</b>	The clause is augmented with the following text:- “ <i>iv. And submission of false (or) hiding information on Beneficial Ownership Declaration Performa required S.R.O. 152(I)/2022”</i>
<b>70</b>	<b>49.10</b>	The Address of PPRA to submit a <b>copy</b> of grievance:  Review Petition Committee Authority, Public Procurement Regulatory Authority 1 <sup>st</sup> Floor, G-5/2, Islamabad, Pakistan Tel: +92-51-9202254
<b>71.</b>	<b>49.13</b>	Following clause may be added: NGC blacklisting policy shall be applicable; however, in case of any conflict between NGC policy and PPRA procedure, the later shall prevail.

**Annex-1 to Bidding Data****Cost Components for Computing Landed Cost (N/A)****A. Imported Goods from Category-III**

1. FOB Price quoted by the Bidder
2. Sea Freight quoted by the Bidder on the basis of PNSC rates, pursuant to Sub-Clause SP-06.2 of Special Provisions
3. CFR Karachi = 1 + 2
4. Insurance quoted by the Bidder
5. CIF Karachi = 3 + 4 quoted by the Bidder
6. Handling Charges @ 1% of CIF Karachi given at Sr. No. 5 above
7. Import Value = 5 + 6 for the purpose of levying Custom Duty
8. Custom Duty, calculated at applicable rate on Import Value given at Sr. No. 7 above
9. Duty Paid Value = 7 + 8
10. Sales Tax, calculated at applicable rate on Duty Paid Value given at Sr. No. 9 above
11. Duty and Sales Tax Paid Value = 9 + 10
12. Withholding Tax, calculated at applicable rate on Duty and Sales Tax Paid Value given at Sr. No. 11 above
13. L/C Charges will be taken as Nil since the same will be borne by the Bidder/Supplier
14. Clearing Charges @ 0.25% of CFR Value given at Sr. No. 3 above
15. SED calculated at applicable rate (currently 1.05%) on Import Value given at Sr. No. 7 above
16. KPT Wharfage @ PKR 140 per cubic meter or the prevailing rate
17. Cranage, Loading and Other Charges @ 0.25% of CFR Value given at Sr. No. 3 above
18. Inland Transportation Charges from Karachi Port to NGC Storage Yard situated at \_\_\_\_\_ (including loading/unloading)
19. Cost of Imported Goods = 11 + 12 + 13 + 14 + 15 + 16 + 17 + 18
20. Less: Handling Charges given at Sr. No. 6 above (Notional Value taken for calculating assessed value for purpose of calculating Custom Duty, Sales Tax and Withholding Tax by the Custom Authority)
21. Total Deductions equal to Sr. No. 20 above
22. Net Cost/Landed Cost of Imported Goods = 19 – 21

**B. Domestically Produced/Manufactured Goods from Category-I or Category-II**

1. Ex-Works Pakistan Price quoted by the Bidder (including all duties and taxes levied on the components and raw materials used in the manufacturing of the offered Goods)
2. Insurance will be taken as Nil since the same will be borne by the Bidder/Supplier
3. Sales Tax, calculated at applicable rate on Ex-Works Pakistan Price given at Sr. No. 1 above
4. Cranage, Loading and Other Charges @ 0.25% of Ex-Works Pakistan Value given at Sr. No. 1 above
5. Inland Transportation Charges from Ex-works in Pakistan to NGC Storage Yard situated at \_\_\_\_\_ (including loading/unloading)
6. Net Cost/Landed Cost of Domestically Produced/Manufactured Goods=1+2+3+4+5

*Note-I: The above factors for value addition shall be substantiated with Certificate issued by Engineering Development Board (EDB) Pakistan.*

*Note-II: Any update changes by Engineering Development Board from time to time shall be incorporated*

## **SECTION-IV: ELIGIBLE COUNTRIES**

### **Eligible Countries**

All the bidders having Pakistani nationality are allowed to participate in the subject procurement. However, following countries are ineligible to be the “Origin” of Goods (as mentioned in bidding document) to be procured under this tender:

1. India
2. Israel

Ministry of Interior, Government of Pakistan has notified List of Business-Friendly Countries (BVL), information can be accessed through following link:

<http://www.dgip.gov.pk/Files/Visa%20Categories.aspx#L>

**SECTION V: SCHEDULE OF REQUIREMENTS,  
TECHNICAL SPECIFICATIONS**

### Schedule of Requirements

The delivery schedule expressed as days stipulates hereafter a delivery date which is the date of delivery:

- (i) On FCS basis at Consignee Store i.e. A-Type Store, 220kV Grid Station, NKLP Lahore.

In order to determine the correct date of delivery hereafter specified, the Procuring Agency has taken into account the additional time that will be needed for international/ national transit to the Project Site or to another common place.

<b>Number</b>	<b>Description</b>	<b>Quantity (Nos.)</b>	<b>Delivery schedule on FCS basis (in days)</b>
1	Procurement of Uniform Items with Accessories/ Liveries for Key Point Installation (Phase-I)	As mentioned in BoQ	90

**SPECIAL PROVISIONS****SP-01 SCOPE****SP-01.1 SCOPE OF SUPPLY**

The scope of supply includes following Goods to meet requirement of Security Staff of NGC in headquarters and field offices.

**PROCUREMENT OF UNIFORM ITEMS WITH ACCESSORIES/  
LIVERIES FOR KEY POINT INSTALLATION (PHASE-I)**

<b>Sr. No.</b>	<b>Description</b>	<b>Qty (Nos.)</b>
1.	Procurement of Uniform Items with Accessories/ Liveries for Key Point Installation (Phase-I)	As mentioned in BoQ

**SP-02 DRAWINGS****SP-02.1 Drawings in Contract****SP-02.1.1 Specification Drawings**

The specification drawings contained in the Contract Documents show the Specifications and Scope of material to be supplied by the Supplier.

**SP-02.1.2 Supplier's Bid Drawings**

The bid drawings are the drawings prepared by the Supplier for bidding purposes, and shall be part of his Bid.

The specification drawings and Supplier's bid drawings shall not be used for manufacturing of Goods unless specific instructions for such use are given by the Engineer.

**SP-02.1.3 Approved Drawings**

The manufacturing shall be carried out in accordance with the approved drawings/data.

**SP-02.2 Drawings and Other Data to be furnished by the Supplier**

All drawings shall be in English language and all dimensions shall be in Metric System. Symbols shall be in accordance with IEC standards. All drawings shall

be clearly marked "National Grid Company of Pakistan (NGC)-(specify item name) \_\_\_\_\_". All drawings/data submitted for approval shall conform to ISO paper sizes A3 or A4.

The Supplier shall submit detailed drawings/data for approval by the Engineer, in accordance with provisions of Contract, and the additional requirements specified in the respective Clauses hereof. The drawings/data shall be complete in all respects, shall have been reviewed and checked by the Supplier and shall be submitted in due time and in logical order to facilitate proper coordination.

#### **SP-02.2.1 Goods Drawings and Specific Goods Data**

The Supplier shall submit the following drawings and Specific Goods Data within fifteen (15) days after issuance of Letter of Acceptance for approval of the Engineer, together with overall and handling weights and dimensions of the Goods to be provided under the Contract.

- (i) Detailed drawings and Specific Goods Data sheets for the Equipment in the respective Lots (if any).
- (ii) Packing details & drawings.
- (iii) Test program indicating arrangement & details of all tests to be carried out and their tentative schedule.
- (iv) Any other information and drawing which may be required by the Engineer.

The time for approval of the Supplier's above mentioned submissions shall be fourteen (14) working days after its receipt thereof.

#### **SP-02.2.2 Data other than Drawings**

All applicable requirements of this Clause and mentioned elsewhere in this document with reference to drawings to be prepared by the Supplier shall apply equally to catalogues, cuts, illustrations, printed specifications, or other data submitted for approval.

#### **SP-02.3 Submission and Approvals**

##### **SP-02.3.1 Drawings for Approval**

Drawings for approval, shall be distributed through international/national couriers to addresses and in number as specified in Sub-Clause SP-02.3.6 hereof.

All drawings submitted for approval shall be provided with a blank white space, approximately 90 mm in height by 120 mm in width, near the lower right-hand corner to be used for notations by the Engineer.

### **SP-02.3.2 Approval of Drawings/Data**

- (1) All changes will be made and will be marked "APPROVED", "APPROVED EXCEPT AS NOTED" or "RETURNED FOR CORRECTION" on the relevant drawings/data. One print will be returned to the Supplier. The other shall be retained by the Engineer for his own use and for the use of Procuring Agency and shall serve as the Master Copy and shall prevail in case of any doubt or discrepancy subsequently arising.
- (2) If the drawing/data is returned to the Supplier stamped "APPROVED" he may immediately proceed with the manufacturing of Goods. Any drawing/data marked "APPROVED" by the Engineer shall be known as an "Approved Drawing".
- (3) If the drawing/data is returned to the Supplier stamped "APPROVED EXCEPT AS NOTED" he may proceed with the manufacturing of Goods taking into account the corrections and comments noted on the drawing/data. The Supplier shall revise the drawings/data as required and resubmit them in the same routine as before for record purposes.
- (4) If the drawing/data is returned to the Supplier stamped "RETURNED FOR CORRECTION" he shall not proceed with the manufacturing of Goods but shall make the changes and corrections or prepare new drawings/data and resubmit the revised drawing/data to the Engineer for approval at no change in price or Delivery & Completion Schedule. Resubmitted prints and calculations will be subject to the same routine as stated before. Time required for such revisions and re-submittals of drawings/data or calculations will not entitle the Supplier to any extension in Contractual Completion time.
- (5) If the Supplier does not agree with exceptions taken by the Engineer, the Supplier shall state in his letter of re-submittal his reasons for not complying with the Engineer's exceptions. Revision number and date and description of change shall be shown on all drawings or calculations revised.

### **SP-02.3.3 Manufacturing Prior to Approval**

Any manufacturing/fabrication of Goods done prior to the approval of drawings & data shall be at the Supplier's risk. The Engineer shall have the right to reject the said Goods if not conforming to required specifications and drawings or to request additional details and to require the Supplier to make

any change(s) which are necessary to conform to the provisions and intent of these Specifications and such changes shall be made without additional cost to Procuring Agency. The approval of the drawings & data by the Engineer shall not be construed as a complete check but will indicate only that the detailing is satisfactory. Approval by the Engineer of the Supplier's drawings & data shall not be held to relieve the Supplier of the obligations to meet all the requirements of these Specifications or of the responsibility for the correctness of the Supplier's drawings & data or for correct fit and use of assembled Goods furnished by the Supplier.

#### **SP-02.3.4 Sequence of Submission**

The sequence of submission of all drawings shall be such that all information is available for checking each drawing when it is received.

#### **SP-02.3.5 Approved Drawings/Data and Revisions**

All approved drawings/data shall form part of the Contract. If revisions are required after a drawing/data has been approved, the Supplier shall furnish for approval additional copies specified for the initial submission, prior to such revision(s).

#### **SP-02.3.6 Distribution of Drawings and Documents**

The drawings and documents shall be submitted to the Engineer/ Procuring Agency within the time given in the Contract or within such reasonable time as the Engineer may require, and in the number as specified hereunder:

<b>Documents</b>	<b>Engineer</b>		<b>Procuring Agency / Project Director</b>	<b>Total</b>
	<b>Head Office</b>	<b>Site Office</b>		
Drawings for approval	3	-	1	4
Approved Drawings	2	2	1	5
Schedules, specifications and other documents/data	2	1	1	4
Record (As-Built) Drawings and Data	2	-	4	6
Reproducible transparency Record (As-Built) Drawings	1	-	1	2

Record (As-Built) Drawings on Computer compact diskette (CD/DVD) using AutoCAD software	1	-	1	2
Codes and standards	1	-	1	2
Manufacture progress information	2	1	2	5
Insurance Certificates	1	1	2	4
Receiving reports	1	1	2	4
Damage reports	1	1	2	4
Correspondence with Procuring Agency	1	1	1	3
Correspondence with Head office of Engineer	1	1	1	3

### SP-03 STANDARDS AND TYPICAL DESIGN

#### SP-03.1 General

The Specifications cite or imply International Standards and typical design for Goods. Other equivalent standards and typical designs are equally acceptable provided that they in no way detract from the quality, safety, operation ability of the Goods furnished. However, when standards or typical design other than those cited or implied are offered by a bidder, he shall set forth in his Contract the alternative standards proposed so that a direct comparison can be made before Contract Award. Each specific difference from the Specifications shall be clearly indicated by the bidder. If no alternatives are set forth by the bidder, it will be assumed that offered Goods will be in accordance with the International Standards and typical design as cited or implied in the Specifications.

Where the documents provide requirements for manufacturing by specifying a standard such as, for example, one of the international standard organizations which have its origin in one country, it is not the intention to restrict the requirements solely to that standard and that country. Other standards, including standards of other countries will be accepted provided the requirements thereof in the sole opinion of the Engineer are at least equal to the requirements of the standards specified. The bidder may propose an equivalent standard other than that specified, in which case he shall submit the proposed standard and all other information required by the Engineer and shall submit written demonstration that his proposed standard is equivalent or superior to the one specified herein. The submission must be made in English language. Moreover, the bidder shall also supply copy of the latest revision of the standards used in his bid.

#### SP-03.2 Applicable Standards and Codes

- (1) All Goods and design shall be generally in accordance with latest revision of the standards specified in the Technical Provisions except where specifically directed otherwise. If these Specifications conflict with any or all the standards stated in the Technical Provisions, these Specifications shall have precedence and shall govern.
- (2) In case deviation from the above standards is minor, approval of the Engineer may be given to use other national standards prevalent in the country of manufacture. No departure from the standards specified will be considered after the Contract has been awarded unless specific authorization is requested in writing from the Engineer.

**SP-04 PORT OF ENTRY AND DISEMBARKATION**

The Supplier/ bidder would have the option to use either Karachi Port or Port Muhammad Bin Qasim or both or any other seaport in Pakistan as the port(s) of entry and disembarkation, at his own risk and costs. For the purpose of clarification, the term "Wharf at the Port of Karachi" wherever used throughout this document shall mean:

- (a) Wharf at the Port of Karachi, and/or
- (b) Wharf at the Port of Muhammad Bin Qasim

**SP-05 PACKING AND MARKING**

**SP-05.1 Packing**

- (1) Supplier shall prepare and pack all Goods for shipment/delivery in accordance with the requirements of the Contract Documents and in the best possible manner to withstand damage or loss from repeated handling and extremes of climate during transportation and storage at Site. All Goods shall be packed so as to guarantee safe transportation of the Goods to the Site under any conditions and limitations which may be encountered. The manner of packing shall be such that it protects the Goods against breakages, damages and losses from the factory until its arrival at its final destination at the Site.
- (2) The final packing shall be such that the weight and dimensions of packages are within reasonable limits in order to facilitate handling, storage and transportation.

- (3) Before any shipment/delivery is made, the Supplier shall get detailed drawings of the packing approved by the Engineer.

**SP-05.2 Lifting**

The method of lifting, type of equipment and type of slings, used for handling the wooden boxes are subject to approval by the Engineer.

**SP-05.3 Slings**

If the use of slings is necessary, these shall be of a flexible type and preferably manila rope or other non-metallic materials. The use of steel wire, mesh or chain link slings is prohibited unless they are covered with rubber hose or some similar material.

**SP-05.4 Marking**

**SP-05.4.1 Identification Marking**

- (1) All members, parts, units or components of the Goods shall be plainly die-indented with a number to identify the member, part, unit or component itself and with a letter to indicate the type of Goods in accordance with approved drawings.

The identification marking shall be plainly legible and durable and shall be so located that the number or letter is not obscured by other member, part, unit or component when in its assembled position. All the marking on ferrous part or unit shall be made before galvanizing.

- (2) Each crate, case, box, package or bundle shall have labels and or tags made from strong waterproof material and marked in indelible and non-fade-able ink securely attached hereto. These labels or tags shall indicate at least the name of the Project, the Consignee and the manufacturer, the type of Goods or component and the quantity it contains so that it can be easily checked upon delivery. A packing list shall be included in each crate or box.
- (3) Each package delivered under the Contract shall be consecutively numbered and shall also be marked with code number or other identification to be approved by Procuring Agency so that various components of the Goods which are shipped, disassembled and which may not be interchangeable can be identified, collected and stored at the Site together. Additional information and or color coding that may reasonably be required by Procuring Agency to facilitate identification, shipment to stores or site handling and storage will also be provided.

- (4) All boxes weighing in excess of 500 kilograms shall be adequately marked for straining and lifting. Whenever necessary the boxes shall be provided with lifting hooks attached by means of vertical rods secured to strong bottom supports.

#### **SP-05.4.2 Container Marking**

In addition to labels and marking indicated above all packages, bundles, containers cases or boxes shall be clearly and boldly marked on two opposite sides and on the top and all reels on both sides as follows:

Ultimate Consignee	Chief Engineer (AM) North NGC Lahore NTDC House, 34-Industrial Area Gulberg-III, Lahore-Pakistan Through Consignee Store i.e. A-Type Store, 220kV Grid Station, NKLP Lahore.
--------------------	---

Destination	_____
-------------	-------

Contract No.	_____
--------------	-------

Name of Project	_____
-----------------	-------

Weight and Dimension	_____
----------------------	-------

Serial Number	_____
---------------	-------

Inscription	"NGC"
-------------	-------

#### **SP-06 TRANSPORTATION OF GOODS**

##### **SP-06.1 General**

The Supplier/ bidder shall transport the Goods from its place of manufacture or origin to the Procuring Agency's port, then to Consignee Store as mentioned in bidding documents and insurance thereof from its place of manufacturer up to storage site/ware house and shall be solely responsible for selection of routes and carriers, and expediting in order that all shipments are safely and expeditiously transported and arrived at Karachi Sea Port and to Consignee Store. The Supplier shall carry out insurance from its warehouse to the Procuring Agency's warehouse / designated site and shall cover all risks

including inland transportation from Karachi/ any other port in the Procuring Agency's country to its warehouse / designated site.

#### **SP-06.2 Shipping**

The shipment of all the consignments relating to Goods shall be arranged by the Supplier through vessels owned or chartered by the Pakistan National Shipping Corporation (PNSC). In case PNSC is not available to transport the Goods within the time period(s) specified in the Contract, the Supplier after obtaining Non-Availability Certificate (NAC) from PNSC may arrange for such transportation on other ocean carriers except those carrying Israeli Flag. For working out a proper schedule to match the completion of delivery, the Supplier will keep a continuous liaison with the Agent of the respective shipping line within the country of origin.

### **SP-07 SHOP INSPECTION AND ORDERS FOR GOODS**

#### **SP-07.1 Inspection**

Unless otherwise authorized by the Engineer, no Goods shall be shipped from its point of original manufacture or final shop assembly before it has been inspected and approved by the Engineer. Bidder will provide an inspection call to NGC concerned formation when the said material/ uniform items are ready for inspection. An inspection certificate will be issued by NGC in this regard.

#### **SP-07.2 Goods Orders**

The Supplier shall, if requested, provide the Engineer with unpriced copies of the Supplier's purchase orders for Goods or approved sub-Contracted supply at the time any such orders are placed. The Supplier shall also provide the Engineer with any other relevant information requested to ensure proper expediting and scheduling of the deliveries.

#### **SP-07.3 Acceptance of Materials**

- i. The approval by the Engineer of any Goods prior to shipment shall in no way relieve the Supplier of any of his responsibilities for meeting all of the requirements of the Specifications and shall not prevent subsequent rejection if such Goods are later found to be defective or not conforming to the Specifications.
- ii. Site Acceptance Test (SAT) will be conducted by the supplier at designated Store of NGC with the co-ordination of nominated persons of purchaser/ NGC representatives after the delivery of material. A

certificate will be provided by the concerned quarters in this regard.  
(Not Applicable)

## **SP-08 SCHEDULE AND MEETINGS**

### **SP-08.1 Schedule**

- (1) The Supplier shall manufacture & supply the Goods in accordance with the dates/periods specified in **Form-4 of Section-VI: Standard Form**. The Supplier shall regularly review the Schedule and notify the Engineer promptly of any revisions which in his view may be required from time to time.
- (2) Each group of Goods shall be completely delivered. The Supplier shall keep the Engineer informed of the progress of the Contract and notify the Engineer/ NGC approximately **six (6) weeks** in advance, in writing, as to when the Goods will be ready for inspection and for shipping and shall supply lists covering each consignment in sufficient detail to enable the Engineer to check the contents of the packages. The inspection will be carried out at Supplier/ Bidder's premises.
- (3) In preparing the Delivery and Completion Schedule, the Supplier shall fully take into account the requirements (and possibilities) for ocean (or air) freight. Progress of all shipments shall be continuously monitored and the Supplier shall provide staff or agents to expedite all shipments to ensure compliance with the approved Delivery Schedule.

### **SP-08.2 Meetings**

- (1) Soon after the date of Award of Contract, the Engineer will, with the approval of Procuring Agency require a meeting with Procuring Agency and the Supplier at a place mutually agreed upon, to discuss scheduling of drawings & data, manufacture, testing & inspection, scheduled sequences of delivery and other similar problems which may be pertinent to the completion of the Project.
- (2) From time to time during the execution of the Contract, the Engineer may call meetings as deemed necessary for the purpose of progress monitoring and proper execution of the Contract.
- (3) As required by the Engineer, responsible representatives of the Supplier shall attend such meetings.
- (4) All expenses incurred by the Supplier for attending such meetings shall be borne by the Supplier and shall not be reimbursable.

**SP-09                    COMMUNICATIONS WITH THE ENGINEER**

Pursuant to the definition of Engineer, Sub-Clause 1.1(q) of the Particular Conditions of Contract, the Engineer has established a Project Office at Lahore to which the Supplier shall address all communications for the approval of drawings and other submittals etc., as follows:

Engineer,  
Chief Engineer (AM) North, NGC Lahore  
Address: NTDC House, 34-Industrial Area Gulberg-III, Lahore-Pakistan  
Telephone No. 92-42-99263023  
Email: [ce.amnl@ntdc.com.pk](mailto:ce.amnl@ntdc.com.pk)

## TECHNICAL SPECIFICATIONS

### 1.0 GENERAL

- 1.1 All designs, equipment, materials and workmanship shall comply with and be tested in accordance with requirements of the specifications. Equipment or parts, which are not covered by the specifications, shall comply with rules, codes and regulations of the international electro-technical commission or approved National Standardizing bodies.
- 1.2 In case of contradiction between the technical requirements mentioned herein and relevant specifications appended with the tender, the former shall prevail.
- 1.3 The specific reference in these specifications and documents to any material/equipment by brand name, make or catalogue number shall be constructed as establishing standards of quality and performance and not as limiting competition. However, Bidders may offer other similar material/equipment provided they meet the specified standard, design and performance requirements. The Bidder shall furnish adequate technical information about such alternative material/equipment to enable Procuring Agency to determine its acceptability. Procuring Agency shall be the sole judge on the acceptability or otherwise of such alternative material/ equipment.
- 1.4 The Bidder shall note that standards for workmanship, material and equipment and reference to brand names or catalogue numbers designated by Procuring Agency in its Technical Specifications are intended to be descriptive only and not restrictive. The Bidder may substitute alternative standards, brands name and/or catalogue numbers in its Bid, provided that it demonstrates to Procuring Agency satisfaction that the substitutions are substantially equivalent or superior to those designed in the Technical Specifications.
- 1.5 The contract shall be executed in strict conformity with the specifications and/or Drawings given or mentioned in this section and the supplier shall do no 'Work' without proper specifications, instructions and/or Drawings.
- 1.6 Specifications and/or drawings are intended to complement each other so that if anything is shown on the drawings as required but not mentioned in the specifications or vice versa. It shall be of like effect as if shown or mentioned in both. If any errors, omissions or discrepancies are found in the figures, specifications and/or drawings or, if any feature shall appear to the supplier to be indefinite or unclear, the same shall be referred to the Procuring Agency whose written explanation and/or clarification shall be obtained before proceeding with the work.
- 1.7 Approval by the Procuring Agency does not relieve the Manufacturer/Supplier of his responsibility to do the work in accordance with the Contract.

- 1.8 The Manufacturer/ Supplier shall be responsible for any discrepancies, errors omissions in any drawings or other particulars supplied by him whether the Procuring Agency has approved such drawings or particulars or not.
- 1.9 All drawings and documents furnished by the Manufacturer/Supplier in accordance with the Contract shall become the property of the Procuring Agency.
- 1.10 Wherever reference is made in the Technical Specifications to specific standards and codes to be met by the goods and materials to be furnished or tested, the provisions of the latest current edition or revision of the relevant standards or codes in effect shall apply, unless otherwise expressly stated in the Contract. Where such standards and codes are national or relates to a particular country or regions, other authoritative standards that ensure substantial equivalence to the standards and codes specified will be acceptable.
- 1.11 NGC reserves the right to delete or increase/decrease any item from any Lot before award of contract.

## **2. LANGUAGE**

All correspondence, literature, drawings, name plates, diagrams, applicable data, equipment details, instructions and maintenance books and manuals, spare parts, books and descriptive data shall be in the English language.

## **3. TYPE TESTS AS APPLICABLE** *(Not Applicable)*

- 3.1 The offered equipment shall be type tested as per relevant provisions of the specifications.
- 3.2 The bidder shall furnish type test certificates for the said equipment along with the bid. In case of non-submission of type test reports or if type test reports supplied are not to the satisfaction of the Engineer, the bidder shall give an undertaking on stamp paper stating the consent to perform all type tests/special tests on the equipment at bidder's own cost, in accordance with the relevant specifications within the quoted bid price and stipulated delivery time.

All type test certificates/reports, reference list, etc. shall be in English language.

- 3.3 All equipment being supplied shall confirm to type test requirements and shall be subject to routine tests in accordance with requirements stipulated under respective sections.

#### 4. CAPITALIZATION FOR EVALUATION

Not Applicable.

#### 5. DETAILED TECHNICAL SPECIFICATIONS

- 5.1 The technical specifications, attached in Volume II of bidding document, shall apply. The requirements indicated in subsequent clauses shall also have to be met. In case any requirements given in the said clauses differs from that given in the main specification, the requirements given herein shall prevail.

#### 6. PRE-DELIVERY / PRE-SHIPMENT INSPECTION

All the machinery /equipment /goods shall be subject to pre-delivery/pre-shipment inspection as per relevant specification and contract conditions. GRN will be issued from concerned Store after issuance of Inspection Certificate.

#### 7. SCHEDULE OF TECHNICAL DATA (SPECIFIC GOODS DATA) (Not Applicable)

Schedules of Technical Data/ Specific Goods Data regarding equipment/ material be supplied are provided in **Form-7 of Section-VI: Standard Form** of this bidding document. The bidder is required to fill the requisite schedule of technical data and submit the same with the bid. A bid without Schedule of Technical Data/ Specific Goods Data (filled in) shall be considered as non-responsive.

All allied equipment/material offered as a part of main equipment may have (preferably) values over and above IEC ratings/values if not specified in NGC specifications.

## **SECTION-VI: STANDARD FORMS**

## Table of Forms

<b>Form 1A:</b>	Letter of Bid – Technical Proposal
<b>Form 1B:</b>	Letter of Bid – Financial Proposal
<b>Form 2A:</b>	Price Schedules for Goods and Related Services Offered from Abroad (N/A)
<b>Form 2B:</b>	Price Schedule: Goods Manufactured outside Pakistan, already imported
<b>Form 2C:</b>	Price Schedule for Domestic Goods Manufactured within Pakistan
<b>Form 3:</b>	List of Related Services and Completion Schedule
<b>Form 4:</b>	Delivery & Completion Schedule
<b>Form 5:</b>	Schedule of Shipping Weights & Dimensions
<b>Form 6:</b>	Manufacturer’s Authorization
<b>Form 7:</b>	Specific Goods Data (Not Applicable)
<b>Form 8:</b>	Deviations from Technical Provisions
<b>Form 9:</b>	Deviations from Contractual Conditions
<b>Form 10:</b>	Declaration of Local Agent
<b>Form 11:</b>	List of Manufacturers/Subcontractors
<b>Form 12:</b>	Foreign Currency Requirements (Not Used)
<b>Form 13:</b>	Undertaking of Acceptance of And Compliance with the SOP for Blacklisting of Contractors.
<b>Form 14A:</b>	Bidder Information Form
<b>Form 14B:</b>	Bidder’s JV Members Information Form
<b>Form 14C:</b>	General Information & Evidence of Manufacturer’s Capability
<b>Form 14D:</b>	Organization Chart
<b>Form 14E:</b>	Manufacturer’s Experience of Supply Record
<b>Form 14F:</b>	Performance Certificate-Summary of operational Experience
<b>Form 14G:</b>	Current Contract Commitments
<b>Form 14H:</b>	Financial Data
<b>Form 14I:</b>	Annual Turnover Data
<b>Form 14J:</b>	Bank Certificate
<b>Form 14K:</b>	Financial Resources
<b>Form 14L:</b>	Pending Litigation
<b>Form 14M:</b>	Manufacturer’s Orders in Hand
<b>Form 14N:</b>	Manufacturer’s Orders in Pipeline
<b>Form 14O:</b>	Method of Assuring Quality of Goods
<b>Form 14P:</b>	List of Quality Control/Laboratory Equipment
<b>Form 14Q:</b>	Domestic Goods (Value added in Pakistan)
<b>Form 14R:</b>	Comfort Letter
<b>Form 15:</b>	Letter of Acceptance
<b>Form 16:</b>	Form of Bid Security
<b>Form 17:</b>	Bid Securing Declaration (Not Applicable)
<b>Form 18:</b>	Proforma Invoice

**FORM 1A****LETTER OF BID – TECHNICAL PROPOSAL**

Date:

Bid for Contract No: \_\_\_\_\_  
\_\_\_\_\_  
\_\_\_\_\_To Chief Engineer (AM) North, NGC Lahore  
NTDC House, 34-Industrial Area Gulberg-III, Lahore-Pakistan

Gentleman,

We, the undersigned, declare that:

- (a) We have examined and have no reservations to the Bidding Documents, including Addenda No.: \_\_\_\_;
- (b) We offer to supply in conformity with the Bidding Documents and in accordance with the Delivery and Completion Schedule, the Goods as stated below on .....[*mention on Free Delivery to Consignee Store*] basis.

\_\_\_\_\_  
\_\_\_\_\_  
\_\_\_\_\_  
[Bidder to delete item(s) not quoted in its Bid]

- (c) We undertake that the Bid Security and Schedules, Form-2A, 2B & 2C as per requirements of the Bidding Documents are enclosed with the Price Bid.
- (d) Our Bid shall be valid for a period of \_\_\_\_\_ days from the date fixed for the bid submission deadline in accordance with the Bidding Document, and it shall remain binding upon us and may be accepted at any time before the expiration of that period;
- (e) If our Bid is accepted, we commit to submit a Performance Security for the due performance of the Contract;
- (f) We understand that our Bid (Technical Bid & Price Bid), together with your written acceptance thereof included in your Letter of Acceptance, shall constitute a binding contract between us, until a formal Contract is prepared and executed.
- (g) Our firm, including any subcontractors or suppliers for any part of the Contract, have nationalities from the following eligible countries \_\_\_\_\_;
- (h) We are not participating as Bidders, in more than one Bid in this bidding process in accordance with the Bidding Documents;
- (i) Our firm, its affiliates or subsidiaries, including any subcontractors or suppliers for any part of the Contract, has not been declared ineligible/black listed by NGC/WAPDA/DISCOs/any Government/Public department/Donor Agencies at the time of submission of bids;

(j) The following commissions, gratuities, or fees have been paid or are to be paid with respect to the bidding process or execution of the Contract:

Name of Recipient	Address	Reason	Amount
_____	_____	_____	_____
_____	_____	_____	_____

(If none has been paid or is to be paid, indicate "none.")

(k) We agree to permit the Procuring Agency or its representative to inspect our accounts and records and other documents relating to the bid submission and to have them audited by auditors appointed by the Procuring Agency.

(l) We understand that the Forms as per clause BDS-20 attached hereto form part of this Technical Bid.

Name \_\_\_\_\_

In the capacity of \_\_\_\_\_

Signed and Stamped \_\_\_\_\_

Duly authorized to sign the Bid for and on behalf of \_\_\_\_\_ (Name of Bidder)

Date \_\_\_\_\_

Witness:

Name: \_\_\_\_\_

Signature: \_\_\_\_\_

Address: \_\_\_\_\_

Note:

The content of this form shall not be altered.

**FORM 1B**

**LETTER OF BID - FINANCIAL PROPOSAL**

Date:

Bid for Contract No: \_\_\_\_\_

To:

Chief Engineer (AM) North, NGC Lahore  
NTDC House, 34-Industrial Area Gulberg-III, Lahore-Pakistan

Gentleman,

We, the undersigned, declare that:

- (a) We have examined and have no reservations to the Bidding Documents, including Addenda No.: \_\_\_\_;
- (b) We offer to supply in conformity with the Bidding Documents and in accordance with the Delivery and Completion Schedule, the Goods as stated below on .....[ *mention on Free Delivery to Consignee Store*] basis.

\_\_\_\_\_  
\_\_\_\_\_  
[Bidder to delete item(s) not quoted in its Bid]

- (c) The total price of our Bid, excluding any discounts offered in item (d) below is:

Pak Rupees \_\_\_\_\_ (*amount in words*) \_\_\_\_\_ (*amount in figures*) \_\_\_\_\_

and

Foreign Currency \_\_\_\_\_ (*amount in words*) \_\_\_\_\_ (*amount in figures*) \_\_\_\_\_

[Price to be inserted from Price Schedule]

- (d) The discounts, cross discounts offered and the methodology for their application are:

\_\_\_\_\_  
\_\_\_\_\_

- (e) Our Bid shall be valid for a period of \_\_\_\_\_ days from the date fixed for the bid submission deadline in accordance with the Bidding Document, and it shall remain binding upon us and may be accepted at any time before the expiration of that period;
- (f) If our Bid is accepted, we commit to submit a Performance Security for the due performance of the Contract;

- (g) We understand that our Bid (Technical Bid & Price Bid), together with your written acceptance thereof included in your Letter of Acceptance, shall constitute a binding contract between us, until a formal Contract is prepared and executed.
- (h) We understand that you are not bound to accept the lowest evaluated bid or any other bid that you may receive.
- (i) We agree to permit the Procuring Agency or its representative to inspect our accounts and records and other documents relating to the bid submission and to have them audited by auditors appointed by the Procuring Agency.
- (j) We understand that the Forms as per clause BDS-20 attached hereto form part of this Bid.

Name \_\_\_\_\_

In the capacity of \_\_\_\_\_

Signed and Stamped \_\_\_\_\_

Duly authorized to sign the Bid for and on behalf of \_\_\_\_\_ (Name of Bidder)

Date \_\_\_\_\_

Witness:

Name: \_\_\_\_\_

Signature: \_\_\_\_\_

Address: \_\_\_\_\_

Note:

The content of this form shall not be altered.

**PRICE SCHEDULE FORMS**

*[The Bidder shall fill in these Price Schedule Forms in accordance with the instructions indicated. The list of line items in column 1 of the **Price Schedules** shall coincide with the List of Goods and Related Services specified by the Procuring Agency in the Schedule of Requirements.]*

**FORM-2B**  
**PRICE SCHEDULE: GOODS MANUFACTURED OUTSIDE PAKISTAN,**  
**ALREADY IMPORTED**

Sr No.	Description of Material	Quantity (Nos.)	Unit Price (PKR)	Total Rates (PKR)
1	Shirt Sky Blue	944 Nos.		
2	Trouser Navy Blue	944 Nos.		
3	Shoes/Boot DMS Leather long.	472 Pairs		
4	Beret Cap (Maroon)	472 Nos.		
5	Cap Badge Metal NGC	472 Nos.		
6	Arm Shield	472 Nos.		
7	Night Jacket Navy Blue with NGC Security Monogram	47 Nos.		
8	Jersey Blue Full Sleeves	472 Nos.		
9	Vest Cotton Half Sleeves (Round Neck)	944 Nos.		
10	Socks Nylon Black	944 Pairs		
11	Badge of Rank Sergeant	91 Nos.		
12	Nylon Belt Black with plate with NGC Monogram	472 Nos.		
13	Shoulder Title Metal	472 Pairs		
14	Rank of Inspector	40 Pairs		
15	Rain Suit	472 Nos.		
16	Gloves Woolen Navy Blue	472 Pairs		
17	Cap Comforter	472 Nos.		
18	Lanyard Maroon Whistle	472 Nos.		
			<b>Total</b>	
			<b>18% GST</b>	
			<b>Grand Total</b>	

**Notes:**

1. The applicable specifications are to be read carefully before filling up the Schedule of Prices.
2. Non-returnable samples of all BoQ items must be submitted to office of Chief Engineer (AM) North, NGC Lahore, before the time of bid submission on E-PADS. Non-submission of samples may result in rejection of bid.
3. In case of discrepancy, between unit price and total, the unit price will prevail.
4. The Delivery will be on FCS Basis to A-Type Store, 220kV Grid Station NGC NKLP Lahore.

**Signature and Seal of the Bidder**

**FORM-2C****PRICE SCHEDULE FOR DOMESTIC GOODS MANUFACTURED WITHIN PAKISTAN**

<b>Sr No.</b>	<b>Description of Material</b>	<b>Quantity (Nos.)</b>	<b>Unit Price (PKR)</b>	<b>Total Rates (PKR)</b>
1	Shirt Sky Blue	944 Nos.		
2	Trouser Navy Blue	944 Nos.		
3	Shoes/Boot DMS Leather long.	472 Pairs		
4	Beret Cap (Maroon)	472 Nos.		
5	Cap Badge Metal NGC	472 Nos.		
6	Arm Shield	472 Nos.		
7	Night Jacket Navy Blue with NGC Security Monogram	47 Nos.		
8	Jersey Blue Full Sleeves	472 Nos.		
9	Vest Cotton Half Sleeves (Round Neck)	944 Nos.		
10	Socks Nylon Black	944 Pairs		
11	Badge of Rank Sergeant	91 Nos.		
12	Nylon Belt Black with plate with NGC Monogram	472 Nos.		
13	Shoulder Title Metal	472 Pairs		
14	Rank of Inspector	40 Pairs		
15	Rain Suit	472 Nos.		
16	Gloves Woolen Navy Blue	472 Pairs		
17	Cap Comforter	472 Nos.		
18	Lanyard Maroon Whistle	472 Nos.		
			<b>Total</b>	
			<b>18% GST</b>	
			<b>Grand Total</b>	

**Notes:**

1. The applicable specifications are to be read carefully before filling up the Schedule of Prices.
2. Non-returnable samples of all BoQ items must be submitted to office of Chief Engineer (AM) North, NGC Lahore, before the time of bid submission on E-PADS. Non-submission of samples may result in rejection of bid.
3. In case of discrepancy, between unit price and total, the unit price will prevail.
4. The Delivery will be on FCS Basis to A-Type Store, 220kV Grid Station NGC NKLP Lahore.

**Signature and Seal of the Bidder**

**FORM-4****DELIVERY & COMPLETION SCHEDULE**

<b>Sr. No.</b>	<b>Description</b>	<b>Qty.</b>	<b>Delivery schedule (shipment) in days on FCS basis (Required)</b>	<b>Delivery schedule (shipment) in days on FCS basis (Offered)</b>
<b>1</b>	<b>2</b>	<b>3</b>	<b>4</b>	<b>5</b>
1.	Procurement of Uniform Items with Accessories/ Liveries for Key Point Installation (Phase-I)	100%	90	

**NOTE:**

- The percentage for each item indicated in Column 3 above shall be for the respective items given in Schedule of Prices.
- Delivery schedule shall be met within the time specified. Otherwise, liquidated damages will be applicable as per Clause SCC-41 of Section-VIII: Special Conditions of Contract.

**Signature and Seal of the Bidder**

**FORM-5**

**SCHEDULE OF SHIPPING WEIGHTS & DIMENSIONS**

Description of Material	Type of Packing	Dimensions of each Box	Weight of each Box (kgs)		Total Weight (kgs)	
			Net Weight of Material	Gross Weight with packing	Net Weight of Material	Gross Weight with packing
1	2	3	4	5	6	7

**Signature and Seal of the Bidder**

**FORM-6**

**MANUFACTURER’S AUTHORIZATION**

Date:

\_\_\_\_\_

Bid Reference No.: \_\_\_\_\_

To: \_\_\_\_\_  
(Name of Bidder)

WHEREAS we \_\_\_\_\_ who are official Manufacturer of \_\_\_\_\_ (name & description of Goods offered) having factories at (address of factory) \_\_\_\_\_ do hereby authorize M/s \_\_\_\_\_ (Name and address of Bidder) to submit a Bid in relation to the Invitation for Bids indicated above, the purpose of which is to provide the following Goods manufactured by us and to subsequently negotiate and sign the Contract:

Description of Goods: \_\_\_\_\_

No company or firm or individual other than M/s \_\_\_\_\_ are authorized to bid, and conclude the contract for the above goods manufactured by us against this specific IFB.

We hereby extend our full guarantee and warranty in accordance with Clause 28 of the General Conditions of Contract, with respect to the Goods offered by the above firm in reply to this Invitation for Bids

Name: \_\_\_\_\_

In the capacity of: \_\_\_\_\_

Signed: \_\_\_\_\_

Duly authorized to sign the Authorization for and on behalf of \_\_\_\_\_  
(Name of Manufacturer)

Date: \_\_\_\_\_

**Note:** This letter of authority should be on the letter head of the Manufacturer and should be signed by a person competent and having the Power of Attorney to legally bind the Manufacturer.

**FORM-7****SPECIFIC GOODS DATA FOR EQUIPMENT/MATERIAL (Not Applicable)**

<b>Sr. No.</b>	<b>Description</b>	<b>'A'</b>	<b>'B'</b>	<b>'C'</b>
1	<p>Schedules of technical data regarding equipment/ material be supplied are provided as <b>Annex-A</b>, Volume II of this bidding document. The bidder is required to fill the same schedule of technical data and submit with the bid. In case of technical schedule of data for any item/material is missing, relevant NGC Specifications shall be followed for filling and submission of the same. Each page of data should be signed and stamped by the manufacturer. A bid without Schedule of Technical Data/ Specific Goods Data (filled in) shall be considered as nonresponsive.</p> <p>The bidder shall attach the schedule indicating all the technical data needed to explain its design for offered item. The information to be supplied should also include name of manufacturer, model number, technical characteristics and standards the supplied equipment adheres to.</p>			

Signature and Seal of the Bidder:

**FORM-8****DEVIATIONS FROM TECHNICAL PROVISIONS**

It is presumed that the Bidder shall not take any deviation. However, if he intends to take deviations to the specified Technical Provisions, these must be listed in the space provided below keeping in view the contents of ITB Sub-Clause-29.7:

Sr. No.	Clause No. of Technical Provisions	Deviations	Remarks (including justification)

[Note: Attach additional sheets, if necessary]

Signature and Seal of the Manufacturer:

Signature and Seal of the Bidder:

**FORM-9****DEVIATIONS FROM CONTRACTUAL CONDITIONS**

It is presumed that the Bidder shall not take any deviation. However, if he intends to take deviations to the specified Contractual/Commercial Conditions, these must be listed in the space provided below keeping in view the contents of ITB Sub-Clause-29.7:

Sr. No.	Clause No. / Section No.	Deviations	Remarks (including justification)

[Note: Attach additional sheets, if necessary]

**FORM-10 (Not Applicable)**

**DECLARATION OF LOCAL AGENT**

A foreign Bidder wishing to have or already having a local agent shall state the following:

1. Name of Local Agent: \_\_\_\_\_

2. Address & Telephone, Fax Number and e-mail of the Local Agent:

\_\_\_\_\_  
\_\_\_\_\_  
\_\_\_\_\_

3. Services to be performed by the Local Agent.

a. \_\_\_\_\_

b. \_\_\_\_\_

c. \_\_\_\_\_

Signature and Seal of the Bidder:

**FORM-11****LIST OF MANUFACTURERS / SUBCONTRACTORS**

I/We intend to supply Goods from the following manufactures or engage the following subcontractors for supply of Goods. In my/our opinion, the manufacturers/subcontractors named hereunder are reliable and competent to supply Goods for which each is listed.

Enclosed are documentation outlining experience of manufacturers/subcontractors, the curriculum vitae and experience of their key personnel who will be assigned to the Contract, Goods to be supplied, size, location and type of contracts performed in the past.

<b>Description of Goods (Give Details)</b>	<b>Manufacturers/Subcontractors (With Complete Address)</b>
<b>1</b>	<b>2</b>

Note:

In case, the Bidder itself is the manufacturer, the above table should be filled-in and requisite documentation be submitted accordingly.

Signature and Seal of the Bidder:

**FORM-12**

**FOREIGN CURRENCY REQUIREMENTS  
(Not Used)**

**FORM-13****UNDERTAKING OF ACCEPTANCE OF AND COMPLIANCE WITH THE SOP  
FOR BLACKLISTING OF CONTRACTORS**

- A) I, \_\_\_\_\_ [*insert name and position of authorized signatory*], being duly authorized by \_\_\_\_\_ [*insert name of the Bidder/members of joint venture (“JV”) in case the Bidder is a JV*] (hereinafter referred to as the “Bidder”) to execute this Undertaking of Acceptance of and Compliance with the SOP for Blacklisting of Contractors attached herewith (hereinafter referred to as the “SOP”), hereby certify on behalf of the Bidder that we, \_\_\_\_\_ [*insert name of the Bidder*] have read and accept the provisions of the SOP.
- B) I further certify, on behalf of the Bidder, that:
- (i) this Bid has been prepared and submitted in full compliance with the terms and conditions set forth in the SOP;
  - (ii) we have not, directly or indirectly, taken any action which is or constitutes inter alia a corrupt, fraudulent, collusive or coercive act or practice in violation of the SOP; and
  - (iii) we shall continue to comply with the terms and conditions of the SOP as and when amended, during period of evaluation of Bids and, in case we are selected for award of Contract, up to satisfactory completion of the Contract.

\_\_\_\_\_  
**Authorized Signatory**  
**For and on behalf of [*insert name of the Bidder*]**  
**Date:**

**FORM-14A****BIDDER INFORMATION FORM**

*[The Bidder shall fill in this Form in accordance with the instructions indicated below. No alterations to its format shall be permitted and no substitutions shall be accepted.]*

Date: *[insert date (as day, month and year) of Bid submission]*

No.: *[insert number of bidding process]*

Alternative No.: *[insert identification No if this is a Bid for an alternative]*

Page \_\_\_\_\_ of \_\_\_\_\_ pages

1. Bidder's Name <i>[insert Bidder's legal name]</i>
2. In case of JV, legal name of each member : <i>[insert legal name of each member in JV]</i>
3. Bidder's actual or intended country of registration: <i>[insert actual or intended country of registration]</i>
4. Bidder's year of registration: <i>[insert Bidder's year of registration]</i>
5. Bidder's Address in country of registration: <i>[insert Bidder's legal address in country of registration]</i>
6. Bidder's Authorized Representative Information Name: <i>[insert Authorized Representative's name]</i> Address: <i>[insert Authorized Representative's Address]</i> Telephone/Fax numbers: <i>[insert Authorized Representative's telephone/fax numbers]</i> Email Address: <i>[insert Authorized Representative's email address]</i>
7. Attached are copies of original documents of <i>[check the box(es) of the attached original documents]</i> <input type="checkbox"/> Articles of Incorporation (or equivalent documents of constitution or association), and/or documents of registration of the legal entity named above. <input type="checkbox"/> In case of JV, letter of intent to form JV or JV agreement, in accordance with ITB 3.4. <input type="checkbox"/> Establishing that the Bidder is not under the supervision of the Procuring Agency
8. Included are the organizational chart, a list of Board of Directors, and the beneficial ownership.

**FORM-14B****BIDDER'S JV MEMBERS INFORMATION FORM**

*[The Bidder shall fill in this Form in accordance with the instructions indicated below. The following table shall be filled in for the Bidder and for each member of a Joint Venture]].*

Date: *[insert date (as day, month and year) of Bid submission]*

RFB No.: *[insert number of RFB process]*

Alternative No.: *[insert identification No if this is a Bid for an alternative]*

Page \_\_\_\_\_ of \_\_\_\_\_ pages

1. Bidder's Name: <i>[insert Bidder's legal name]</i>
2. Bidder's JV Member's name: <i>[insert JV's Member legal name]</i>
3. Bidder's JV Member's country of registration: <i>[insert JV's Member country of registration]</i>
4. Bidder's JV Member's year of registration: <i>[insert JV's Member year of registration]</i>
5. Bidder's JV Member's legal address in country of registration: <i>[insert JV's Member legal address in country of registration]</i>
6. Bidder's JV Member's authorized representative information Name: <i>[insert name of JV's Member authorized representative]</i> Address: <i>[insert address of JV's Member authorized representative]</i> Telephone/Fax numbers: <i>[insert telephone/fax numbers of JV's Member authorized representative]</i> Email Address: <i>[insert email address of JV's Member authorized representative]</i>
7. Attached are copies of original documents of <i>[check the box(es) of the attached original documents]</i> <input type="checkbox"/> Articles of Incorporation (or equivalent documents of constitution or association), and/or registration documents of the legal entity named above, in accordance with ITB 4.4.
8. Included are the organizational chart, a list of Board of Directors, and the beneficial ownership.

**FORM-14C****GENERAL INFORMATION & EVIDENCE OF MANUFACTURER'S  
CAPABILITY**

Bidder to provide the following information with the bid and indicate herein its references where this information is available.

Sr. No.	Information to be Supplied	Bid References
1.	Manufacturer's <ul style="list-style-type: none"><li>• Name:</li><li>• Business Address:</li><li>• Contact Telephone Nos.</li><li>• Fax No:</li><li>• E-mail:</li><li>• Country of Incorporation:</li><li>• Location and address of manufacturing facilities:</li></ul>	
2.	Full description of factories owned and the annual manufacturing capacities of various items made therein.	
3.	Details of the factory or factories where the offered Goods are proposed to be manufactured. This description should include the facilities and capacities of the particular factories including testing facilities and the processes used in manufacturing and testing. Where parts or components are purchased from outside, the details of equipment purchased and the names and experience record of the suppliers.	
4.	Detailed description of the quality control testing and research facilities. If the Goods are manufactured under license, the name of the licensor and details of the licensing arrangements, such as the duration of the license, the facilities provided to the bidder by the licensor and whether future improvements are available or not, etc. A copy of the license agreement may be attached.	
5.	Names, qualifications and experience of the key technical personnel.	

- 6. The time in years since the Manufacturer has been in this business;
- and the time in years since he has been doing work of similar nature:
- 7. The time in years since the Goods offered are being Manufactured;
- and the time in years for which it has been in service;
- 8. Quantity produced [Sets/Numbers/Km] in last ten (10) years:
  - (i) Year 01: \_\_\_\_\_
  - (ii) .....
  - (iii) .....
  - (iv) .....
  - (v) Year 10: \_\_\_\_\_
- 9. Manufactured under own License? Yes No
- 10. Manufactured under License from: \_\_\_\_\_
- 11. Manufactured in collaboration with: \_\_\_\_\_
- 12. Has Manufacturer R&D Section? Yes No
- 13. Has Manufacturer a Quality Assurance Plan (QAP) in place? Yes No
- 14. Is the Manufacturer certified or accredited by an organization? Yes No
- 15. Name the organization and type of certification/accreditation: \_\_\_\_\_
- 16. Is the Manufacturer's testing facilities/laboratory accredited by an organization? Yes No
- 17. Name the organization and type of certification/accreditation for the laboratory: \_\_\_\_\_

**Note:**

Copy of the following document shall be attached:

- (a) Quality Assurance Plan (ISO 9001) from the Manufacturer.
- (b) Accreditation certificates.

Name of the Manufacturer \_\_\_\_\_  
 Signed and stamped by the Manufacturer \_\_\_\_\_  
 Signature and Seal of the Bidder \_\_\_\_\_

**FORM-14D**

**ORGANIZATION CHART**

The Bidder shall provide the Organization Chart of his organization to execute the Contract.

Signature and Seal of the Bidder:

**FORM-14E**

**MANUFACTURER’S EXPERIENCE OF SUPPLY RECORD**

(For a period of Last 5 Years)

Name of the Equipment/Goods: .....

Order Placed by (full address of Purchaser)	Order No. and date	Description and quantity of ordered equipment (Also see Note # 2 below)	Value of order	Date of completion of delivery as per contract	Date of actual completion of delivery	Remarks indicating reasons for late delivery, if any	Has the equipment been installed satisfactorily ? (Attach a certificate from the Purchaser/ consignee)	Contact person along with Telephone No., Fax No. and email address

Note:

1. The qualification documents submitted by the Bidder may not be considered for evaluation if copies of contract agreement(s) and completion certificate(s) are not provided with the Bid.
2. The Bidder shall mention Project Name with Country name giving details

Signature and Seal of the Manufacturer:

Signature and Seal of the Bidder:

**FORM-14F****PERFORMANCE CERTIFICATE  
Summary of operational Experience**

It is certified that M/s. \_\_\_\_\_ has supplied the following materials for the quantities indicated against each.

Sr. No.	Order No. & Date	Designation & address of order placing authority/User	Description of Material/ Equipment	Quantity	Name of line / Substation along with voltage rating where material installed	Date of Commissioning	Performance of Material / Equipment

Signature & seal of the Bidder

Note:

Bidder shall attach the operational certificate as per Clause BDS-28 with this Performa.

**FORM-14G****CURRENT CONTRACT COMMITMENTS**

Bidder and each partner of JV (in case of JV) should provide information on their current commitments on all contracts that have been awarded, or for which a letter of intent or acceptance has been received, or for contracts approaching completion.

<b>Sr. No.</b>	<b>Particulars of Contracts executed</b>	<b>Order No. &amp; Date</b>	<b>Name of order placing Authority</b>	<b>Ordered Value (PKR)*</b>	<b>Contract Completion Date</b>	<b>Remaining Contract Period (in months)</b>	<b>Value of balance work (PKR)*</b>	<b>Monthly Financial Resources Requirement (PKR)*</b>
<b>(1)</b>	<b>(2)</b>	<b>(3)</b>	<b>(4)</b>	<b>(5)</b>	<b>(6)</b>	<b>(7)</b>	<b>(8)</b>	<b>(9)</b>
1								
2								
3								
4								
5								
6								
7								

\* Total ordered value and value of balance work should be converted to US\$/PKR at exchange rate (selling) prevailing at the date of submission of Bids.

Signature and Seal of the Bidder:

**FORM-14H****FINANCIAL DATA**

The Bidder and each JV partner (in case of JV) shall complete the information in this Form.

Name of the Bidder/JV Partner: \_\_\_\_\_

<b>Financial Data for Last (05) Years</b>					
<b>Fiscal Year</b>					
<b>Information for Balance Sheet</b>					
<b>Total Assets</b>					
<b>Total Liabilities</b>					
<b>Net Worth</b>					
<b>Current Assets</b>					
<b>Current Liabilities</b>					
<b>Information from Income Statement</b>					
<b>Total Revenues</b>					
<b>Profits Before Taxes</b>					
<b>Profits After Taxes</b>					
<p>Attach copies of financial statements (balance sheets including all related notes, and income statements) for the last three years, as indicated above, complying with the following conditions:</p> <ul style="list-style-type: none"> <li>• All such documents must reflect the financial situation of the Bidder and not sister, affiliate or parent companies.</li> <li>• Historic financial statements must be audited by a chartered accountant whose certificate of incorporation with its concerned accreditation body for example Association of Chartered Accountants of X-Country shall be submitted with the Bid.</li> <li>• Historic Financial statements must be complete, including all notes to the financial statements.</li> <li>• Historic financial statements must correspond to accounting periods already completed and audited (no statements for partial periods shall be requested or accepted).</li> </ul>					

Signature and Seal of the Bidder:

**FORM-14I****ANNUAL TURNOVER DATA**

Name of the Bidder/JV Partner: \_\_\_\_\_

Bidder and each Joint Venture Partner (in case of JV) are requested to complete the information in this form separately.

Annual turnover data for the following last five fiscal years			
<b>Year</b>	<b>Amount (Currency)</b>	<b>Exchange Rate*</b>	<b>Equivalent Amount (US\$/PKR)</b>
<b>Average Annual Turnover (for best three years)</b>			

\* Exchange rate (selling) prevailing at the date of submission of Bids.

Signature and Seal of the Bidder:

**FORM-14J**

**BANK CERTIFICATE**

This is to certify that M/s..... is a reputed company with a good financial standing.

If the contract for Supply of Goods namely .....is awarded to the above firm, we shall be able to provide overdraft/credit facilities to the extent of PKR/US\$..... to meet their working capital requirements for executing the above contract.

Signature of Senior Bank Manager: \_\_\_\_\_  
Name of the Senior Bank Manager: \_\_\_\_\_  
Address of the Bank: \_\_\_\_\_

Stamp of the Bank

Note: Certificate should be on the letter head of the bank.

▪ **Change the text as follows for Joint Venture:**

This is to certify that M/s..... who has formed a JV with M/s.....and M/s..... for participating in this bid, is a reputed company with a good financial standing.

If the contract for supply of Goods namely .....is awarded to the above Joint Venture, we shall be able to provide overdraft/credit facilities to the extent of PKR/US\$.....to M/s..... to meet the working capital requirements for executing the above contract.

[This should be given by each of the JV members in proportion to their financial participation.]

**FORM-14K****FINANCIAL RESOURCES**

Specify proposed sources of financing, such as liquid assets, lines of credit, and other financial means less current commitments to meet the total cash flow demands of this contract.

<b>Financial Resources</b>			
<b>Sr. No.</b>	<b>Source of Financing</b>	<b>Amount (currency)</b>	<b>Equivalent Amount* (US\$/PKR)</b>
1	Liquid Assets		
2	Credit Lines		
3	Other Financial Means		
4.	<b>Total (1+2+3)</b>		
5	Current Commitments		
6	Net Available Financial Resources (4-5)		

\* Converted to US\$/PKR at exchange rate (selling) prevailing at the date of submission of Bids.

Signature and Seal of the Bidder:

**FORM-14L****PENDING LITIGATION**

Each Bidder or member of a JV must fill in this form.

<b>Pending Litigation</b>					
Year	Name of Other Party(ies)	Matter in Dispute	Litigation whether in Courts or Arbitration	Amount involved	
				Pending or Threatened	Resolved
Total					
% age of Net Worth					

Signature and Seal of Bidder:

**FORM-14M****MANUFACTURER'S ORDERS IN HAND AND ITS IMPLEMENTATION  
SCHEDULE**

Manufacturer should provide following information on their all contracts/orders in hand, that have been awarded or for which a letter of intent or acceptance has been received, or for contracts approaching completion.

Sr. No.	Particulars of Contracts/ Orders in hand	Order No & Date	Name of Order Placing Authority	Order Completion Date	Remaining Contract Period (in months)	Ordered Quantity	Balance Quantity Yet to be supplied
						Nos.	Nos.
(1)	(2)	(3)	(4)	(5)	(6)	(7)	(8)
1.							
2.							
3.							
4.							
5.							
6.							
7.							
Total							

Signature and Seal of the Manufacturer:

Signature and Seal of the Bidder:

**FORM-14N****MANUFACTURER'S EXPECTED ORDERS IN PIPELINE**

<b>Sr. No</b>	<b>Particulars of Expected Orders</b>	<b>Name of Expected Order Placing Authority</b>	<b>Expected Order Quantity</b>
			Nos.
<b>(1)</b>	<b>(2)</b>	<b>(3)</b>	<b>(4)</b>
1.			
2.			
3.			
4.			
5.			
6.			
7.			
Total			

Signature and Seal of the Manufacturer:

Signature and Seal of the Bidder:

**FORM-140**

**METHOD OF ASSURING QUALITY OF GOODS**

The Bidder is required to submit a narrative in detail the method of assuring quality of Goods to be manufactured.

Signature and Seal of the Manufacturer:

Signature and Seal of the Bidder

**FORM-14P**

**LIST OF QUALITY CONTROL/LABORATORY EQUIPMENT**

The Bidder will provide list of all equipment and related items, to carry out the quality control tests. The information shall include make, type, capacity, and anticipated period of utilization for all equipment which shall be in sufficient detail to demonstrate fully that the equipment will meet all requirements of the Specifications.

Signature and Seal of the Manufacturer:

Signature and Seal of the Bidder:

**FORM-14Q****Domestic Goods  
(Value added in Pakistan)**

Sr. No.	Description of Indigenous Goods	Unit	Qty.	Total Price of Goods Ex-Works (Eq. PKR) *	Amount of value addition (PKR)	Domestic value added in the manufacturing cost as percentage of Ex-Works Price
1	2	3	4	5	6	7
Total in columns 5 & 6						

**Note:**

1. Bidders claiming eligibility for domestic preference should provide necessary documentation regarding inter alia the breakdown of the Ex-Works Price including but not limited to cost of imported raw material, duties, taxes and other incidental charges up to factory paid thereon, domestic labour, domestic raw materials & components, domestic overheads incurred, profit margin, etc. to substantiate their claim.
2. Domestic Value Addition comprises domestic labour, domestic raw materials & components, domestic overheads from the stage of mining the raw material until final assembly.  
\* converted at the exchange rate prevailing at the date of submission of Bids.

**Signature and Seal of the Bidder**

**FORM-14R**

**COMFORT LETTER**

Bid for Contract No. \_\_\_\_\_ : \_\_\_\_\_ [Title of Contract]

To:

Chief Engineer (AM), NGC Lahore  
NTDC House, 34-Industrial Area Gulberg-III, Lahore-Pakistan  
Telephone No. 92-42-99263023  
Gentleman,

- i. This is to certify that if the Contract for Supply of Goods namely ..... to be supplies from..... [Insert name of country] is awarded to M/s ..... incorporated under laws of..... [insert name of country], we are able as well as willing to provide/extend unconditional banking facilities including but not limited to opening of letter of credit or making payment through direct payment procedure, retirement of shipping documents, issuance of Electronic Import Form (EIF) for custom clearance purposes, etc.
- ii. We understand that the issuance of this letter does not create any obligation for NGC.

Signature of Senior Bank Manager \_\_\_\_\_  
 Address of Senior Bank Manager \_\_\_\_\_  
 Name of the bank \_\_\_\_\_

▪ **Change the text under para (i) as follow in case of Joint Venture.**

M/s ..... incorporated under the laws of..... [Insert name of country] has formed a JV with M/s ..... and M/s..... For participating in this bid.

- i. This is to certify that if the Contract for Supply of Goods namely ..... to be supplies from..... [insert name of country] is awarded to the above Joint Venture, we are able as well as willing to provide/extend unconditional banking facilities including but not limited to opening of letter of credit or making payment through direct payment procedure, retirement of shipping documents, issuance of Electronic Import Form (EIF) for custom clearance purposes, etc.
- ii. We understand that the issuance of this letter does not create any obligation for NGC. [This should be given by each of the JV members]

**Note:**

- Certificate should be on the letter head of Scheduled Bank in Pakistan.
- It is clarified that the requirement of “Comfort Letter” has been included purely for payment purposes to ensure the availability of banking channels for smooth execution

of Contract. The “Comfort Letter” is neither a Bank Guarantee nor is required to determine financial soundness of the Bidder, and does not create any legal obligation to bank, but rather is a simple confirmation on bank’s letter head that in case of award of Contracts to specific firm, the banking channels will be available for making payment by NGC in favor of Supplier. Moreover, a Bank can provide confirmation in its own wording without changing the substance of letter i.e., assuring to provide banking channel if given business.

**FORM-15****LETTER OF ACCEPTANCE***[Letter head paper of the Procuring Agency]***NOTIFICATION OF AWARD/LETTER OF ACCEPTANCE*****Contractor/Supplier*****SUBJECT:** \_\_\_\_\_

Dear Sir,

**Reference: Your bid submitted dated \_\_\_\_\_ against subject tender**

We are pleased to inform you that NGC has accepted your bid for supply of \_\_\_\_\_ in the quantities and at the prices mentioned below subject to your agreeing to and fulfilling the conditions stated hereunder and complying with the specifications and terms & conditions of the Bidding Documents. All other provisions/conditions in the **Bidding Documents No. \_\_\_\_\_** not mentioned herein shall remain in full force and effect and any deviation(s) or discrepancy (s) from the same stated or observed in your Bid or post-bid correspondence stand withdrawn/rectified by you.

**1. PRICES AND QUANTITIES**

<b>Item No.</b>	<b>Description</b>	<b>Qty.</b>	<b>Unit</b>	<b>Unit Price FCS Basis (PKR)</b>	<b>Total Price FCS Basis (PKR)</b>
				<b>18% GST</b>	
				<b>Total Price (PKR)</b>	
<b>In Words:</b>					

**2. DOCUMENTS FOR L/C**

As per Clause SCC-36 of Section-VIII: Special Conditions of Contract.

**3. IMPLEMENTATION SCHEDULE**

At the time of acceptance of NOA, you will also submit project implementation plan & program with Bar Chart showing all activities to complete the contract within the stipulated Delivery Period.

**4. TERMS OF PAYMENT**

As per Clause SCC-35 of Section –VIII: Special Conditions of Contract.

**5. DELIVERY SCHEDULE**

As per Form-4 of Section-VI: Standard Forms.

**6. LIQUIDATED DAMAGES**

As per clause SCC-40 of Section-VIII: Special Conditions of Contract.

**7. SHIPMENT**

- i) At the time of shipment , the following information will simultaneously be supplied to Manager (Custom Clearance & Logistics) NGC, Bungalow No. 44-N/1, Block-6, PECHS Karachi , Pakistan and to this office:
  - a) Number of Packages showing measurement/dimensions of each package with description of goods.
  - b) Net weight of each Package with itemized Break-Up of goods contained in the Package.
  - c) Gross weight of each Package with itemized Break-up of goods contained in the Package.
  - d) Volume of each Package.
  - e) Other information/documents as required by Procuring Agency.
- ii) In case of delay in submission of information on requisite documents, the Financial Implication shall be attributable to Supplier's account.
- iii) As per clause GCC-12 of Section-VII: General Conditions of Contract , the packing of goods as is required to prevent their damages or deterioration during transit to their final destination, as indicated in the contract. During transit, the packing shall be sufficient to withstand, without limitation, rough handling and exposure to extreme temperature, salt and precipitation and open storage. Packing case size and weight shall be taken into consideration, where appropriate, the remoteness of the final destination or the goods and the absence of heavy handling facilities at all points in transit.
- iv) The packing, marking and documentation within and outside the packages shall comply strictly with such special requirements as shall be expressly provided for in the

Contract, including additional requirements, if any, specified in the PCC, and in any other instructions ordered by the Procuring Agency.

- v) The Supplier has to load material within standard capacity of containers and strictly avoid using old rusty containers while loading of NGC material to avoid unnecessary financial losses in shape of container repair / damage charges otherwise, same would be recovered from the supplier.

## 8. INSURANCE

As per clause SCC-28 & SCC-29 of Section-VIII: Special Conditions of Contract.

## 9. PERFORMANCE SECURITY

As per clause SCC-16 of Section-VIII: Special Conditions of Contract.

## 10. TECHNICAL LITERATURE / DRAWINGS

As per Clause-SP-02.2.1 of Section-V: Schedule of Requirements, Technical Specifications.

## 11. INSPECTION/TESTING

- i. As per clause \_\_\_\_\_ of bidding documents, **Supplier/Contractor/Manufacturer** shall arrange the Pre-delivery Inspection of the offered material in accordance with the provisions of the Bidding Document within the quoted bid price and stipulated delivery schedule.
- ii. The pre-delivery inspection shall be carried out at your works and will be witnessed by two (2) authorized representatives/inspectors of **Engineer/Employer**. In this connection, all expenses shall be borne by **Supplier/Contractor/Manufacturer** in accordance with the Bidding Document.
- iii. **Supplier/Contractor/Manufacturer** shall inspect the material themselves and only after fully convinced about the quantity and quality, they shall offer the material for NGC inspection and shall also ensure that NOA, approved Schedule of Technical Data & Drawings along with relevant specifications, standards etc. are available at the manufacturer's works before the material is offered for inspection.
- iv. **Supplier/Contractor/Manufacturer** shall make all the test reports, raw material test certificates and in-process test reports and shall maintain complete traceability from raw material to finished material in bilingual with English and shall produce reports/records as and when asked by NGC.

## 12. RESPONSIBILITY FOR EXECUTING THE CONTRACT

You are entirely responsible for the successful execution of the Contract in all respects

and in accordance with the terms and conditions as specified in the Notification of Award/Contract and the Bidding Document No: \_\_\_\_\_.

**13. FORMATION OF CONTRACT**

This Notification of Award and its acceptance by the firm will constitute the formation of the Contract, binding the Employer/ Procuring Agency and the Contractor/Supplier/Manufacturer till signing of the formal Contract Agreement.

Please convey your acceptance to this **Notification of Award/Letter of Acceptance** being sent in duplicate by appending your signatures and stamp on each page and return one copy as soon as possible but not later than a fortnight from the date of issuance of this **Notification of Award/ Letter of Acceptance**.

**ACCEPTED**

For and On Behalf of  
*Supplier/Contractor/Manufacturer*

For and On Behalf of  
**National Grid Company of  
Pakistan Limited (NGC)**

\_\_\_\_\_

**Chief Engineer (AM) North,  
NGC Lahore**

CC to:-  
(relevant stakeholders)

**FORM-16****FORM OF BID SECURITY  
(Bank Guarantee)**

Security Executed on \_\_\_\_\_  
(Date)

Name of Surety (Bank) with address \_\_\_\_\_  
(Scheduled Bank in Pakistan)

Name of Principal (Bidder) with  
Address: \_\_\_\_\_

Guaranteed Amount/Sum of Security  
Rupees \_\_\_\_\_ (Rs. \_\_\_\_\_)  
Bid Reference No. \_\_\_\_\_

KNOW ALL MEN BY THESE PRESENTS, that in pursuance of the terms of the Bid and at the request of the said Principal (Bidder) we, the Surety above named, are held and firmly bound unto \_\_\_\_\_ (Hereinafter called the ' Procuring Agency ') in the sum stated above for the payment of which sum well and truly to be made, we bind ourselves, our heirs, executors, administrators and successors, jointly and severally,. firmly by these presents.

THE CONDITION OF THIS OBLIGATION IS SUCH, that whereas the Bidder has submitted the accompanying Bid dated \_\_\_ for Bid No. \_\_\_ for \_\_\_ (Particulars of Bid) to the said Procuring Agency; and

WHEREAS, the Procuring Agency has required as a condition for considering said Bid that the Bidder furnishes a Bid Security in the above said sum to the Procuring Agency, conditioned as under:

- (1) That the Bid Security shall remain in force up to and including the date 28 days after the deadline for validity of bids as stated in the Instructions to Bidders or as it may be extended by the Procuring Agency, notice of which extension(s) to the Surety is hereby waived;
- (2) That the Bid Security of unsuccessful Bidders will be returned by the Procuring Agency after expiry of its validity or upon signing of the Contract Agreement; and
- (3) That in the event of failure of the successful Bidder to execute the proposed Contract Agreement and furnish the required Performance Security, the entire said sum be paid immediately to the said Procuring Agency pursuant to Clause 18.9 of the Instructions to Bidders for the successful Bidder's failure to perform.

NOW THEREFORE, if the successful Bidder shall, within the period specified therefor, on the prescribed form presented to him for signature enter into a formal Contract with the said Procuring Agency in accordance with his Bid as accepted and furnish within fourteen (14) days of his being requested to do so, a Performance Security with good and sufficient surety, as may be required, upon the form prescribed by the said Procuring Agency for the faithful performance and proper fulfillment of the said Contract or in the event of non-withdrawal of the said Bid within the time specified for its validity then this obligation shall be void and of no effect, but otherwise to remain in full force and effect.

PROVIDED THAT the Surety shall forthwith pay the Procuring Agency the said sum upon first written demand of the Procuring Agency (without cavil or argument) and without recourse to the Principal or any other third party in the necessity any proceeding whatever judicial or otherwise irrespective of any dispute, difference or disagreement between the Bidder and the Procuring Agency or contestation by any other party/person. We agree that for the purpose of this Bid Bond, the Procuring Agency shall be the sole and exclusive judge for determining whether events listed in \_\_\_\_ above have occurred and any written demand made in the manner stipulated herein by the P Procuring Agency shall be conclusive evidence of the occurrence of one or more of the events listed above. We shall at all times be bound to the first written demand of the Procuring Agency to pay the Procuring Agency forthwith the amount hereby agreed and without requiring the Procuring Agency to prove or to show grounds or reasons for such demand, notice of which shall be sent by the Procuring Agency by registered post duly addressed to the Surety at its address given above.

PROVIDED ALSO THAT the Procuring Agency shall be the sole and final judge for deciding whether the Principal (Bidder) has duly performed his obligations to sign the Contract Agreement and to furnish the requisite Performance Security within the time stated above, or has defaulted in fulfilling the said requirements and the Surety shall pay without objection the said sum upon demand from the Procuring Agency forthwith and without any reference to the Principal (Bidder) or any other person.

IN WITNESS, WHEREOF, the above bounden Surety has executed the instrument under its seal on the date indicated above, the name and seal of the Surety being hereto affixed and these presents duly signed by its undersigned representative pursuant to authority of its governing body.

Witness:

Guarantor (Bank)

1. \_\_\_\_\_

Signature \_\_\_\_\_

\_\_\_\_\_  
Corporate Secretary (Seal)

Name \_\_\_\_\_

2. \_\_\_\_\_

Title \_\_\_\_\_

\_\_\_\_\_  
Name, Title & Address

\_\_\_\_\_  
Corporate Guarantor (Seal)

Note:

The content of this form shall not be altered.

**FORM-17****BID SECURING DECLARATION**

*[The Bidder shall fill in this Form in accordance with the instructions indicated.]*

Date: *[insert date (as day, month and year)]*

Bid No.: *[insert number of Bidding process]*

Alternative No.: *[insert identification No if this is a Bid for an alternative]*

To: *[insert complete name of Procuring Agency]*

We, the undersigned, declare that:

We understand that, according to your conditions, Bids must be supported by a Bid Securing Declaration.

We accept that we will be blacklisted and henceforth cross debarred for participating in respective category of public procurement proceedings for a period of (not more than) six months, if fail to abide with a bid securing declaration, however without indulging in corrupt and fraudulent practices, if we are in breach of our obligation(s) under the Bid conditions, because we:

- (a) have withdrawn or modified our Bid during the period of Bid Validity specified in the Form of Bid;
- (b) Disagreement to arithmetical correction made to the Bid price; or
- (c) having been notified of the acceptance of our Bid by the Procuring Agency during the period of Bid Validity, (i) failure to sign the contract if required by Procuring Agency to do so or (ii) fail or refuse to furnish the Performance Security or to comply with any other condition precedent to signing the contract specified in the Bidding Documents.

We understand this Bid Securing Declaration shall expire if we are not the successful Bidder, upon the earlier of (i) our receipt of your notification to us of the name of the successful Bidder; or (ii) twenty-eight (28) days after the expiration of our Bid.

Signed: *[insert signature of person whose name and capacity are shown]* In the capacity of *[insert legal capacity of person signing the Bid Securing Declaration]*

Name: *[insert complete name of person signing the Bid Securing Declaration]*

Duly authorized to sign the Bid for and on behalf of: *[insert complete name of Bidder]*

Dated on \_\_\_\_\_ day of \_\_\_\_\_, \_\_\_\_\_ *[insert date of signing]*  
Corporate Seal (where appropriate)

**FORM-18****PROFORMA INVOICE**

(Proforma Invoice is to submitted on the official letter head of the Supplier/Contractor)

Invoice No. \_\_\_\_\_

Dated: \_\_\_\_\_

**National Grid Company of Pakistan Limited (NGC)**  
**O/o Chief Engineer (AM) North, NGC Lahore**  
**NTDC House, 34-Industrial Area Gulberg-III, Lahore-Pakistan**

Tender No. \_\_\_\_\_

Tender Description \_\_\_\_\_

Lot # \_\_\_\_\_

Lot Description \_\_\_\_\_

Sr. No.	Description	Qty.	Unit Price	Total Price
<b>Total Price (including GST)</b>				
<b>Total Price in words:</b>				

**Payment Terms:**

\_\_\_\_\_

\_\_\_\_\_

\_\_\_\_\_

**Delivery Term:**

\_\_\_\_\_

\_\_\_\_\_

\_\_\_\_\_

**Origin of Goods:** \_\_\_\_\_

**H.S Code:** \_\_\_\_\_

**Beneficiary Details for Letter of Credit:**

**Beneficiary Name & Complete Address:**

\_\_\_\_\_  
**Name and Complete Address of Beneficiary Bank:**

\_\_\_\_\_  
**Swift Code:**

\_\_\_\_\_  
**Beneficiary's bank account number:**

\_\_\_\_\_

**Signature and Seal of the Contractor**

**PART-B**

**CONDITIONS OF CONTRACT AND CONTRACT  
FORMS**

**SECTION VII: GENERAL CONDITIONS OF THE  
CONTRACT**

**GENERAL CONDITIONS OF THE CONTRACT (GCC)**

1.	<b>Definitions</b>	1.1	The following words and expressions shall have the meanings hereby assigned to them:
			a) <b>“Authority”</b> means Public Procurement Regulatory Authority.
			b) The <b>“Arbitrator”</b> is the person appointed with mutual consent of both the parties, to resolve contractual disputes as provided for in the General Conditions of the Contract <b>GCC Clause 31</b> hereunder.
			c) The <b>“Contract”</b> means the agreement entered into between the Procuring Agency and the Supplier, as recorded in the Contract Form signed by the parties, including all attachments and appendices thereto and all documents incorporated by reference therein.
			d) The <b>“Commencement Date”</b> is the date when the Supplier shall commence execution of the contract as specified in the <b>SCC</b> .
			e) <b>“Completion”</b> means the fulfillment of the related services by the Supplier in accordance with the terms and conditions set forth in the contract.
			f) <b>“Country of Origin”</b> means the countries and territories eligible under the PPRA Rules 2004 and its corresponding Regulations as further elaborated in the <b>SCC</b> .
			g) The <b>“Contract Price”</b> is the price stated in the Letter of Acceptance and thereafter as adjusted in accordance with the provisions of the Contract.
			h) <b>“Defective Goods”</b> are those goods which are below standards, requirements or specifications stated by the Contract.
			i) <b>“Delivery”</b> means the transfer of the goods from the supplier equipment, machinery, and /or other materials which the Supplier is required to supply to the Procuring Agency under Contract.
			j) <b>“Effective Contract date”</b> is the date shown in the Certificate of Contract Commencement issued by the Procuring Agency upon fulfillment of the conditions precedent stipulated in <b>GCC Clause 3</b> .
			k) <b>“Procuring Agency”</b> means the person named as Procuring Agency in the <b>SCC</b> and the legal successors in title to this person, procuring the Goods and related service, as named in <b>SCC</b> .

			l)	<b>“Related Services”</b> means those services ancillary to the delivery of the Goods, such as transportation and insurance, and any other incidental services, such as installation, commissioning, provision of technical assistance, training, initial maintenance and other such obligations of the Supplier covered under the Contract.
			m)	<b>“GCC”</b> means the General Conditions of Contract contained in this section.
			n)	<b>“Intended Delivery Date”</b> is the date on which it is intended that the Supplier shall effect delivery as specified in the SCC.
			o)	<b>“SCC”</b> means the Special Conditions of Contract.
			p)	<b>“Supplier”</b> means the individual private or government entity or a combination of the above whose Bid to perform the contract has been accepted by the Procuring Agency and is named as such in the Contract Agreement, and includes the legal successors or permitted assigns of the supplier and shall be named in the SCC.
			q)	<b>“Project Name”</b> means the name of the project stated in SCC.
			r)	<b>“Day”</b> means calendar day.
			s)	<b>“Eligible Country”</b> means the countries and territories eligible for participation in accordance with the policies of the Federal Government.
			t)	<b>“End User”</b> means the organization(s) where the goods will be used, as named in the SCC.
			u)	<b>“Origin”</b> means the place where the Goods were mined, grown, or produced or from which the Services are supplied. Goods are produced when, through manufacturing, processing, or substantial and major assembly of components, a commercially recognized new produce results that is substantially different in basic characteristics or in purpose or utility from its components.
			v)	<b>“Force Majeure”</b> means an unforeseeable event which is beyond reasonable control of either Party and which makes a Party’s performance of its obligations under the Contract impossible or so impractical as to be considered impossible under the circumstances.  For the purposes of this Contract, <b>“Force Majeure”</b> means an event which is beyond the reasonable control of a Party, is not foreseeable, is unavoidable, and its origin is not due to negligence or lack of care on the part of a Party, and which makes a Party’s performance of its obligations hereunder

			impossible or so impractical as reasonably to be considered impossible in the circumstances. and includes, but is not limited to, war, riots, civil disorder, earthquake, fire, explosion, storm, flood, epidemics, or other adverse weather conditions, strikes, lockouts or other industrial action (except where such strikes, lockouts or other industrial action are within the power of the Party invoking Force Majeure to prevent), confiscation or any other action by Government agencies.
		w)	<b>“Specification”</b> means the Specification of the Goods and performance of incidental services in accordance with the relevant standards included in the Contract and any modification or addition made or approved by the Procuring Agency.
		x)	The Supplier's Bid is the completed Bid document submitted by the Supplier to the Procuring Agency.
<b>2.</b>	<b>Application and interpretation</b>	2.1	These General Conditions shall apply to the extent that they are not superseded by provisions of other parts of the Contract.
		2.2	In interpreting these Conditions of Contract headings and marginal notes are used for convenience only and shall not affect their interpretations unless specifically stated; references to singular include the plural and vice versa; and masculine include the feminine. Words have their ordinary meaning under the language of the Contract unless specifically defined.
		2.3	The documents forming the Contract shall be interpreted in the following order of priority:  (1) Form of Contract, (2) Special Conditions of Contract, (3) General Conditions of Contract, (4) Letter of Acceptance, (5) Certificate of Contract Commencement (6) Specifications (7) Contractor's Bid, and (8) Any other document listed in the Special Conditions of Contract as forming part of the Contract.

3.	<b>Conditions Precedent</b>	3.1	Having signed the Contract, it shall come into effect on the date on which the following conditions have been satisfied: -  a) Submission of performance Security (or guarantee) in the form specified in the SCC;  b) Furnishing of Advance Payment Unconditional Guarantee.
		3.2	If the Condition precedent stipulated on GCC Clause 3.1 is not met by the date specified in the SCC this contract shall not come into effect;
		3.3	If the Procuring Agency is satisfied that each of the conditions precedent in this contract has been satisfied (except to the extent waved by him, but subject to such conditions as he shall impose in respect of such waiver) he shall promptly issue to the supplier a certificate of Contract commencement, which shall confirm the start date.
4.	<b>Governing Language</b>	4.1	The Contract as all correspondence and documents relating to the contract exchanged by the Supplier and the Procuring Agency shall be written in the language specified in SCC. Subject to <b>GCC Clause 3.1</b> , the version of the Contract written in the specified language shall govern its interpretation.
5.	<b>Applicable Law</b>	5.1	The contract shall be governed and interpreted in accordance with the laws of Pakistan, unless otherwise specified in SCC.
6.	<b>Country of Origin</b>	6.1	The origin of Goods and Services may be distinct from the nationality of the Supplier.
7.	<b>Standards</b>	7.1	The Goods supplied under this Contract shall conform to the standards mentioned in the Technical Specifications, and, when no applicable standard is mentioned, the American Standards (such as ACI, IEEE, ASME, etc.) or the Pakistani standards such as PSQCA. Such standards shall be the latest issued by the concerned institution.
8.	<b>Use of Contract Documents and Information; Inspection and Audit by the Government of Pakistan</b>	8.1	The Supplier shall not, without the Procuring Agency's prior written consent, disclose the Contract, or any provision thereof, or any specification, plan, drawing, pattern, sample, or information furnished by or on behalf of the Procuring Agency in connection therewith, to any person other than a person employed by the Supplier in the performance of the Contract. Disclosure to any such employed person shall be made in confidence and shall extend only as far as may be necessary for purposes of such performance.

		8.2	The Supplier shall not, without the Procuring Agency's prior written consent, make use of any document or information enumerated in <b>GCC Clause 7.1</b> except for purposes of performing the Contract.
		8.3	Any document, other than the Contract itself, enumerated in <b>GCC Clause 7.1</b> shall remain the property of the Procuring Agency and shall be returned (all copies) to the Procuring Agency on completion of the Supplier's performance under the Contract if so required by the Procuring Agency.
		8.4	The Supplier shall permit the Government of Pakistan or / and donor agencies involved in financing the project to inspect the Supplier's accounts and records relating to the performance of the Supplier and to have them audited by auditors appointed by the Government of Pakistan or / and the appropriate donor agencies, if so required by the Government of Pakistan or / and the appropriate donor agencies.
<b>9.</b>	<b>Patent and Copy Rights</b>	9.1	The Supplier shall indemnify the Procuring Agency against all third-party claims of infringement of patent, trademark, or industrial design rights arising from use of the Goods or any part thereof in Pakistan.
		9.2	The patent right in all drawings, documents, and other materials containing data and information furnished to the Procuring Agency by the Supplier herein shall remain vested in the supplier, or, if they are furnished to the Procuring Agency directly, or through the Supplier by any third party, including suppliers of materials, the patent right in such materials shall remain vested in such third party.
<b>10.</b>	<b>Performance Security (or Guarantee)</b>	10.1	The Performance Security (or Guarantee) shall be provided to the Procuring Agency no later than the date specified in the Letter of Acceptance and shall be issued in an amount and form and by a bank or surety acceptable to the Procuring Agency, and denominated in the types and proportions of the currencies in which the Contract Price is payable as specified in the <b>SCC</b> .
		10.2	The proceeds of the Performance Security (or Guarantee) shall be payable to the Procuring Agency as compensation for any loss resulting from the Supplier's failure to complete its obligations under the Contract.
		10.3	The Performance Security (or Guarantee) shall be in one of the following forms:
		a)	A bank guarantee, an irrevocable letter of credit issued by a reputable bank, or in the form provided in the Bidding Documents or another form acceptable to the Procuring Agency; or
		b)	A cashier's or certified check.

		10.4	The performance security (or guarantee) will be discharged by the Procuring Agency and returned to the Supplier not later than thirty (30) days following the date of completion of the Supplier's performance obligations under the Contract, including any warranty obligations, unless otherwise specified in SCC.
<b>11.</b>	<b>Inspections and Test</b>	11.1	The Procuring Agency or its representative shall have the right to inspect and /or to test the Goods to confirm their conformity to the Contract specifications at no extra cost to the Procuring Agency. SCC and the Technical Specifications shall specify what inspections and tests the Procuring Agency shall notify the Supplier in writing or in electronic forms that provide record of the content of communication, in a timely manner, of the identity of any representatives retained for these purposes.
		11.2	The inspections and tests may be conducted on the premises of the Supplier or its subcontractor(s), at point of delivery, and/or at the Goods' final destination. If conducted on the premises of the Supplier or its subcontractor(s), all reasonable facilities and assistance, including access to drawings and production data, shall be furnished to the inspectors at no charge to the Procuring Agency.
		11.3	Should any inspected or tested Goods fail to conform to the Specifications, the Procuring Agency may reject the Goods, and the Supplier shall replace the rejected Goods to meet specification requirements free of cost to the Procuring Agency.
		11.4	The Procuring Agency's right to inspect, test and, where necessary, reject Goods after the Goods' arrival in the Procuring Agency's country shall in no way be limited or eared by reason of the Goods having previously been inspected, tested, and passed by the Procuring Agency or its representative prior to the Goods' shipment from the country of origin.
		11.5	Nothing in <b>GCC Clause 10</b> shall in any way release the supplier from any warranty or other obligations under this Contract.
<b>12.</b>	<b>Packing</b>	12.1	The supplier shall provide such packing of the Goods as is required to prevent their damage or deterioration during transit to their final destination, as indicated in the Contract. The packing shall be sufficient to withstand, without limitation, rough handling during transit and exposure to extreme temperatures, salt and precipitation during transit, and open storage. Packing case size and weights shall take into consideration, where appropriate, the remoteness of the Goods final destination and the absence of heavy handling facilities at all points in transit.

		12.2	The packing, marking, and documentation within and outside the packages shall comply strictly with such special requirements as shall be expressly provided for in the Contract, including additional requirements, if any, specified in <b>SCC</b> , and in any subsequent instructions ordered by the Procuring Agency.
<b>13.</b>	<b>Delivery and Documents</b>	13.1	Delivery of the Goods shall be made by the Supplier in accordance with the terms specified in the Schedule of Requirements. The details of shipping and or other documents to be furnished by the Supplier as specified in <b>SCC</b> .
		13.2	For purposes of the Contract, “EXW”, “FOB”, “FCA”, “CIF”, “CIP,” and other trade terms used to describe the obligations of the parties shall have the meanings assigned to them by the current edition of INCOTERMS published by the International Chamber of Commerce, Paris.
		13.3	Documents to be submitted by the Supplier are specified in <b>SCC</b> .
<b>14.</b>	<b>Insurance</b>	14.1	The Goods supplied under the Contract shall be fully insured in a freely convertible currency against loss or damage incidental to manufacture or acquisition, transportation, storage, and delivery in the manner specified in the <b>SCC</b> .
<b>15.</b>	<b>Transportation</b>	15.1	Where the Supplier is required under Contract to deliver the Goods FOB, transport of the Goods, up to and including the point of putting the Goods on board the vessel at the specified port of loading, shall be arranged and paid for by the Supplier, and the cost thereof shall be included in the Contract Price. Where the Supplier is required under the Contract to deliver the Goods FCA, transport of the Goods and delivery into the custody of the carrier at the place named by the Procuring Agency or other agreed point shall be arranged and paid for by the Supplier, and the cost thereof shall be included in the Contract Price.
		15.2	Where the Supplier is required under Contract to deliver the Goods CIF or CIP, transport of the Goods to the port of destination or such other named place of destination in Pakistan, as shall be specified in the Contract, shall be arranged and paid for by the Supplier, and the cost thereof shall be included in the Contract Price.
		15.3	Where the Supplier is required under the Contract to transport the Goods to a specified place of destination within Pakistan, defined as the Project Site, transport to such place of destination in Pakistan, including insurance and storage, as shall be specified in the Contract, shall be arranged by the Supplier, and related costs shall be included in the Contract Price.
<b>16.</b>	<b>Related Services</b>	16.1	The Supplier may be required to provide any or all of the following services, including additional services, if any, specified in <b>SCC</b> :

			a)	Performance or supervision of on-site assembly, Installation Commissioning and/or start-up of the supplied Goods;
			b)	Furnishing of tools required for assembly and/or maintenance of the supplied Goods;
			c)	Furnishing of a detailed operations and maintenance manual for each appropriate unit of the supplied Goods;
			d)	Performance or supervision or maintenance and/or repair of the supplied Goods, for a period of time agreed by the parties, provided that this service shall not relieve the Supplier of any warranty obligations under this Contract; and
			e)	Training of the Procuring Agency's personnel, at the Supplier's plant and/or on-site, in assembly, start-up, operation, maintenance, and/or repair of the supplied Goods.
		16.2		Prices charged by the Supplier for related services, if not included in the Contract Price for the Goods, shall be agreed upon in advance by the parties and shall not exceed the prevailing rates charged to other parties by the Supplier for similar services.
<b>17.</b>	<b>Spare Parts</b>	17.1		As specified in SCC, the Supplier may be required to provide any or all of the following materials, notifications, and information pertaining to spare parts manufactured or distributed by the Supplier:
			a)	Such spare parts as the Procuring Agency may elect to purchase from the Supplier, provided that this election shall not relieve the Supplier of any warranty obligations under the Contract; and
			b)	In the event of termination of production of the spare parts: <ul style="list-style-type: none"> <li>i) advance notification to the Procuring Agency of the pending termination, in sufficient time to permit the Procuring Agency to procure needed requirements; and</li> <li>ii) following such termination, furnishing at no cost to the Procuring Agency, the blueprints, drawings, and specifications of the spare parts, if requested.</li> </ul>

<b>18.</b>	<b>Warranty/ Defect Liability Period</b>	18.1	The Supplier warrants that the Goods supplied under the Contract are new, unused, of the most recent or current models and that they incorporate all recent improvements in design and materials unless provided otherwise in the Contract. The Supplier further warrants that all Goods supplied under this Contract shall have no defect, arising from design, materials, or workmanship (except when the design and/or material is required by the Procuring Agency, specifications) or from any act or omission of the Supplier, that may develop under normal use of the supplied Goods in the conditions prevailing in Pakistan.
		18.2	This warranty shall remain valid for a period specified in the <b>SCC</b> after the Goods, or any portion thereof as the case may be, have been delivered to and accepted at the final destination indicated in the Contract, or for a period specified in the <b>SCC</b> after the date of shipment from the port or place of loading in the source country, whichever period concludes earlier, unless specified otherwise in <b>SCC</b> .
		18.3	The Procuring Agency shall promptly notify the Supplier in writing or in electronic forms that provide record of the content of communication of any claims arising under this warranty.
		18.4	Upon receipt of such notice, the Supplier shall, within the period specified in <b>SCC</b> and with all reasonable speed, repair or replace the defective Goods or parts thereof, without costs to the Procuring Agency.
		18.5	If the Supplier, having been notified, fails to remedy the defect(s) within the period specified in <b>SCC</b> , the Procuring Agency may proceed to take such remedial action as may be necessary, at the Supplier's risk and expense and without prejudice to any other rights which the Procuring Agency may have against the Supplier under the Contract.
<b>19.</b>	<b>Payment</b>	19.1	The method and conditions of payment to be made to the Supplier under this Contract shall be specified in <b>SCC</b> .
		19.2	The Supplier's request(s) for payment shall be made to the Procuring Agency in writing or in electronic forms that provide record of the content of communication, accompanied by an invoice describing, as appropriate, the Goods delivered and Services performed, and by documents submitted pursuant to <b>GCC Clause 13</b> , and upon fulfillment of other obligations stipulated in the Contract.

		19.3	Payments shall be made promptly by the Procuring Agency, within sixty (60) days after submission of an invoice or claim by the Supplier. If the Procuring Agency makes a late payment, the Supplier shall be paid interest on the late payment. Interest shall be calculated from the date by which the payment should have been made up to the date when the late payment is made at the rate as specified in the SCC.
		19.4	The currency or currencies in which payment is made to the Supplier under this Contract shall be specified in SCC subject to the following general principle: payment will be made in the currency or currencies in which the payment has been requested in the Supplier's Bid.
		19.5	All payments shall be made in the currency or currencies specified in the SCC pursuant to <b>GCC Clause 19.4</b>
<b>20.</b>	<b>Prices</b>	20.1	The contract price shall be as specified in the Contract Agreement Subject to any additions and adjustments thereto or deductions there from, as may be made pursuant to the Contract.
		20.2	Prices charged by the Supplier for Goods delivered and Services performed under the Contract shall not vary from the prices quoted by the Supplier in its Bid, with the exception of any price adjustments authorized in SCC or in the Procuring Agency's request for Bid Validity extension, as the case may be.
<b>21.</b>	<b>Change Orders</b>	21.1	The Procuring Agency may at any time, by a written order given to the Supplier pursuant to <b>GCC Clause 22</b> , make changes within the general scope of the Contract in any one or more of the following:
		a)	Drawings, designs, or specifications, where Goods to be furnished under the Contract are to be specifically manufactured for the Procuring Agency;
		b)	The method of shipment or packing;
		c)	The place of delivery; and/or
		d)	The Services to be provided by the Supplier.
		21.2	If any such change causes an increase or decrease in the cost of, or the time required for, the Supplier's performance of any provisions under the Contract an equitable adjustment shall be made in the Contract Price or delivery schedule, or both, and the Contract shall accordingly be amended. Any claims by the Supplier for adjustment under this clause must be asserted within thirty (30) days from the date of the Supplier's receipt of the Procuring Agency change order.
		21.3	Prices to be charged by the supplier for any related services that might be needed but which were not included in the Contract shall be agreed upon in advance by the Parties and shall not exceed the prevailing rates charged to other parties by the Supplier for similar services.

<b>22.</b>	<b>Contract Amendments</b>	22.1	Subject to <b>GCC Clause 20</b> , no variation in or modification of the terms of the Contract shall be made except by written amendment signed by the parties.
<b>23.</b>	<b>Assignment</b>	23.1	Neither the Procuring Agency nor the Supplier shall assign, in whole or in part, obligations under this Contract, except with the prior written consent of the other party.
<b>24.</b>	<b>Sub-contracts</b>	24.1	The Supplier shall consult the Procuring Agency in the event of subcontracting under this contract if not already specified in the Bid. Subcontracting shall not alter the Supplier's obligations.
		24.2	Subcontracts must comply with the provision of <b>GCC Clause 5</b> .
<b>25.</b>	<b>Delays in the Supplier's Performance</b>	25.1	Delivery of the Goods and performance of Services shall be made by the Supplier in accordance with the time schedule prescribed by the Procuring Agency in the Schedule of Requirements.
		25.2	If at any time during performance of the Contract, the Supplier or its subcontractor(s) should encounter conditions impeding timely delivery of the Goods and performance of Services, the Supplier shall promptly notify the Procuring Agency in writing or in electronic forms that provide record of the content of communication of the fact of the delay, its likely duration and its cause(s). As soon as practicable after receipt of the Supplier's notice, the Procuring Agency shall evaluate the situation and may at its discretion extend the Supplier's time for performance, with or without liquidated damages, in which case the extension shall be ratified by the parties by amendment of Contract.
		25.3	Except as provided under <b>GCC Clause 28</b> , a delay by the Supplier in the performance of its delivery obligations shall render the Supplier liable to the imposition of liquidated damages pursuant to <b>GCC Clause 26</b> , unless an extension of time is agreed upon pursuant to <b>GCC Clause 25.2</b> without the application of liquidated damages.
<b>26.</b>	<b>Liquidated Damages</b>	26.1	Subject to <b>GCC Clause 28</b> , if the Supplier fails to deliver any or all of the Goods or to perform the Services within the period(s) specified in the Contract, the Procuring Agency shall, without prejudice to its other remedies under the Contract, deduct from the Contract Price, as liquidated damages, a sum equivalent to the percentage specified in <b>SCC</b> of the delivered price of the delayed Goods or unperformed Services for each week or part thereof of delay until actual delivery or performance, up to a maximum deduction of the performance security (or guarantee) specified in <b>SCC</b> . Once the said maximum is reached, the Procuring Agency may consider termination of the Contract pursuant to <b>GCC Clause 26</b> .

27.	<b>Termination for Default</b>	27.1	The Procuring Agency or the Supplier, without prejudice to any other remedy for breach of Contract, by written notice of default sent to the concerned party may terminate the Contract if the other party causes a fundamental breach of the Contract.
		27.2	Fundamental breaches of Contract shall include, but shall not be limited to the following:
			a) the Supplier fails to deliver any or all of the Goods within the period(s) specified in the Contract, or within any extension thereof granted by the Procuring Agency pursuant to <b>GCC Clause 24</b> ; or
			b) the Supplier fails to perform any other obligation(s) under the Contract;
			c) Supplier's failure to submit performance security (or guarantee) within the time stipulated in the <b>SCC</b> ;
			d) the supplier has abandoned or repudiated the contract.
			e) the Procuring Agency or the Supplier is declared bankrupt or goes into liquidation other than for a reconstruction or amalgamation;
			f) a payment is not paid by the Procuring Agency to the Supplier after 84 days from the due date for payment;
			g) the Procuring Agency gives Notice that goods delivered with a defect is a fundamental breach of Contract and the Supplier fails to correct it within a reasonable period of time determined by the Procuring Agency; and
			h) if the Procuring Agency determines, based on the reasonable evidence, that the Supplier has engaged in corrupt, coercive, collusive, obstructive or fraudulent practices, in competing for or in executing the Contract.
			For the purpose of this clause:
			<b>"Corrupt and Fraudulent Practice"</b> means the practices as described in Rule-2 (1) (f) of Public Procurement Rules-2004.
		27.4	In the event the Procuring Agency terminates the Contract in whole or in part, pursuant to <b>GCC Clause 26.1</b> , the Procuring Agency may procure, upon such terms and in such manner as it deems appropriate, Goods or Services similar to those undelivered, and the Supplier shall be liable to the Procuring Agency for any excess costs for such similar Goods or Services. However, the Supplier shall continue performance of the Contract to the extent not terminated.

<b>28.</b>	<b>Termination for Force Majeure</b>	28.1	<p>Notwithstanding the provisions of <b>GCC Clauses 25, 26, and 27</b>, neither Party shall have any liability or be deemed to be in breach of the Contract for any delay nor is other failure in performance of its obligations under the Contract, if such delay or failure is a result of an event of Force Majeure.</p> <p>For purpose of this clause, ‘Force Majeure’ means an event which is beyond the reasonable control of a Party, is not foreseeable, is unavoidable, and its origin is not due to negligence or lack of care on the part of a Party, and which makes a Party’s performance of its obligations hereunder impossible or so impractical as reasonably to be considered impossible in the circumstances, and includes, but is not limited to, war, riots, civil disorder, earthquake, fire, explosion, storm, flood, epidemics, or other adverse weather conditions, strikes, lockouts or other industrial action (except where such strikes, lockouts or other industrial action are within the power of the Party invoking Force Majeure to prevent</p>
		28.2	<p>If a Party (hereinafter referred to as “the Affected Party”) is or will be prevented from performing its substantial obligation under the contract by Force Majeure, it shall give a Notice to the other Party giving full particulars of the event and circumstance of Force Majeure in writing or in electronic forms that provide record of the content of communication of such condition and the cause thereof. Unless otherwise directed by the Procuring Agency in writing or in electronic forms that provide record of the content of communication, the Supplier shall continue to perform its obligations under the Contract as far as is reasonably practical, and shall seek all reasonable alternative means for performance not prevented by the Force Majeure event.</p>
<b>29.</b>	<b>Termination for Insolvency</b>	29.1	<p>The Procuring Agency may at any time terminate the Contract by giving written notice to the Supplier if the Supplier becomes bankrupt or otherwise insolvent. In this event, termination will be without compensation to the Supplier, provided that such termination will not prejudice or affect any right of action or remedy which has accrued or will accrue thereafter to the Procuring Agency.</p>
<b>30.</b>	<b>Termination for Convenience</b>	30.1	<p>The Procuring Agency, by written notice sent to the Supplier, may terminate the contract, in whole or in part, at any time for its convenience. The notice of termination shall specify that termination is for the Procuring Agency’s convenience, the Contract is terminated, and the date upon which such termination becomes effective.</p>

		30.2	The Goods that are complete and ready for shipment within thirty (30) days after the Supplier's receipt of notice of termination shall be accepted by the Procuring Agency at the Contract terms and price. For the remaining Goods, the Procuring Agency may elect:	
			a)	To have any portion completed and delivered at the Contract terms and prices; and / or
			b)	To cancel the remainder and pay to the Supplier an agreed amount for partially completed Goods and Services and for materials and parts previously procured by the Supplier.
<b>31.</b>	<b>Disputes Resolution</b>	31.1	In the event of any dispute arising out of this contract, either party shall issue a notice of dispute to settle the dispute amicably. The parties hereto shall, within twenty-eight (28) days from the notice date, use their best efforts to settle the dispute amicably through mutual consultations and negotiation. Any unsolved dispute may be referred by either party to an arbitrator that shall be appointed by mutual consent of the both parties.	
		31.2	After the dispute has been referred to the arbitrator, within 30 days, or within such other period as may be proposed by the Parties, the Arbitrator shall give its decision. The rendered decision shall be binding to the Parties.	
<b>32.</b>	<b>Procedure for Disputes Resolution</b>	32.1	The arbitration shall be conducted in accordance with the arbitration procedure published by the Institution named and in the place shown in the SCC.	
		32.2	The rate of the Arbitrator's fee and administrative costs of arbitration shall be borne equally by the Parties. The rates and costs shall be in accordance with the rules of the Appointing Authority. In conducting arbitration to its finality each party shall bear its incurred costs and expenses.	
		32.3	The arbitration shall be conducted in accordance with the arbitration procedure published by the institution named and in the place shown in the SCC.	
<b>33.</b>	<b>Replacement of Arbitrator</b>	33.1	Should the Arbitrator resign or die, or should the Procuring Agency and the Supplier agree that the Arbitrator is not functioning in accordance with the provisions of the contract, a new Arbitrator shall be appointed by mutual consent of the both parties.	
<b>34.</b>	<b>Limitation of Liability</b>	34.1	Except in cases of criminal negligence or willful conduct, and in the case of infringement pursuant to <b>GCC Clause 8</b> ,	
			a)	The supplier shall not be liable to the Procuring Agency, whether in contract, tort, or otherwise, for any indirect or consequential loss or damage, loss of use, loss of production, or loss of profits or interest costs, provided that this exclusion shall not apply to any obligation of the Supplier to pay liquidated damages to the Procuring Agency; and

			b)	The aggregate liability of the Supplier to the Procuring Agency, whether under the Contract, in tort or otherwise, shall not exceed the total Contract Price, provided that this limitation shall not apply to the cost of repairing or replacing defective equipment or to any obligation of the Supplier to indemnify the Procuring Agency with respect to patent infringement.
<b>35.</b>	<b>Notices</b>	35.1		Any notice given by one party to the other pursuant to this Contract shall be sent to the other party in writing or in electronic forms that provide record of the content of communication and confirmed in writing or in electronic forms that provide record of the content of communication to the other party's address specified in <b>SCC</b> .
		35.2		A notice shall be effective when delivered or on the notice's effective date, whichever is later.
<b>36.</b>	<b>Taxes and Duties</b>	36.1		A foreign Supplier shall be entirely responsible for all taxes, stamp duties, license fees, and other such levies imposed outside Pakistan.
		36.2		If any tax exemptions, reductions, allowances or privileges may be available to the Supplier in Pakistan the Procuring Agency shall use its best efforts to enable the Supplier to benefit from any such tax savings to the maximum allowable extent.
		36.3		A local Supplier shall be entirely responsible for all taxes, duties, license fees, etc., incurred until delivery of the contracted Goods to the Procuring Agency.

**SECTION VIII: SPECIAL CONDITIONS OF THE  
CONTRACT (SCC)**

**SPECIAL CONDITIONS OF CONTRACT (SCC)**

The following Special Conditions of Contract (SCC) shall supplement the GCC. Whenever there is a conflict, the provisions herein shall prevail over those in the GCC. The corresponding clause number of the GCC is indicated in parentheses.

<b>SCC Clause Number</b>	<b>GCC Clause Number</b>	<b>Amendments of, and Supplements to, Clauses in the GCC</b>
		<b>Definitions (GCC 1)</b>
1.	1.1 (k)	The Procuring Agency is: <b>National Grid Company of Pakistan (NGC)</b> represented by  Chief Engineer (AM) North NGC Lahore NTDC House, 34-Industrial Area Gulberg-III, Lahore-Pakistan Telephone No. 92-42-99263023 Email: <a href="mailto:ce.amnl@ntdc.com.pk">ce.amnl@ntdc.com.pk</a>
2.	1.1(j)	The Supplier is: [ <i>Name and address</i> ]
3.	1.1(q)	The title of the subject Project is: <b>PROCUREMENT OF UNIFORM ITEMS WITH ACCESSORIES/ LIVERIES FOR KEY POINT INSTALLATION (PHASE-I)</b>
4.	1.1 (y)	The definition is inserted after 1.1 (x)  The Engineer is <b>Chief Engineer (AM) North NGC</b> or any other Competent Person appointed by the Procuring Agency and notified to the Supplier, to act in replacement of the Engineer. Provided always that except in cases of professional misconduct, the outgoing Engineer is to formulate his certifications/recommendations in relation to all outstanding matters, disputes and claims relating to the execution of the Contract during his tenure.
5.	1.1 (z)	The terms “Supplier” and “Contractor” are synonymous.
6.	1.1 (aa)	The terms “Purchaser”, “Procuring Agency” and “Employer” are synonymous.
7.	1.1 (ab)	The terms “Works”, “Equipment” and “Goods are synonymous.

8.	1.1 (ac)	“Subcontractor” means any natural person, private or government entity or a combination of the above, including its legal successors or permitted assigns, to whom any part of the Goods to be supplied is subcontracted by the Supplier.
<b>Application and Interpretation (GCC 2)</b>		
9.	2.2	<p>Add the following at the end of Clause-2.2</p> <p><b>(a) The Entire Agreement</b></p> <p>The Contract constitutes the entire agreement between the Procuring Agency and the Supplier and supersedes all communications, negotiations and agreements (whether written or oral) of parties with respect thereto made prior to the date of Contract.</p> <p><b>(b) Incoterms</b></p> <p>The meaning of any trade term and the rights and obligations of parties thereunder shall be as prescribed by Incoterms.</p> <p>i. EXW, CIF, DDP, and other similar terms, shall be governed by the rules prescribed in the current edition of Incoterms, published by the International Chamber of Commerce at the date of the Invitation for Bids or as specified in the PCC.</p> <p><b>(c) Amendment</b></p> <p>No amendment or other variation of the Contract shall be valid unless it is in writing, is dated, expressly refers to the Contract, and is signed by a duly authorized representative of each party thereto.</p> <p><b>(d) Nonwaiver</b></p> <p>i. Subject to Sub-Clause 2.2(c)(ii) below, no relaxation, forbearance, delay, or indulgence by either party in enforcing any of the terms and conditions of the Contract or the granting of time by either party to the other shall prejudice, affect, or restrict the rights of that party under the Contract, neither shall any waiver by either party of any breach of Contract operate as waiver of any subsequent or continuing breach of Contract.</p> <p>ii. Any waiver of a party’s rights, powers, or remedies under the Contract must be in writing, dated, and signed by an authorized representative of the party granting such waiver,</p>

		<p>and must specify the right and the extent to which it is being waived.</p> <p><b>(e) Severability</b></p> <p>If any provision or condition of the Contract is prohibited or rendered invalid or unenforceable, such prohibition, invalidity or unenforceability shall not affect the validity or enforceability of any other provisions and conditions of the Contract.</p>
10.	2.3	<p>Delete Clause-2.3 and replace it with the following:</p> <p>The documents forming the Contract shall be interpreted in the following order of priority:</p> <ol style="list-style-type: none"> <li>(1) Form of Contract,</li> <li>(2) Letter of Acceptance,</li> <li>(3) Priced Schedules of Prices submitted by the Supplier;</li> <li>(4) Special Conditions of Contract,</li> <li>(5) General Conditions of Contract,</li> <li>(6) Form No. 4 to 13;</li> <li>(7) Specifications: Technical Provisions;</li> <li>(8) Specifications: Special Provisions;</li> <li>(9) Contractor's Bid, and</li> <li>(10) Any other item</li> </ol>
		<b>Conditions Precedent (GCC 3)</b>
11	3.1 (b)	Shall not be applicable.
		<b>Governing Language (GCC 4)</b>
12	4.1	<p>The Governing Language shall be: English</p> <p>Add the following at the end of Clause GCC 4.1</p> <p>Supporting documents and printed literature that are part of the Contract may be in another language provided they are accompanied by an accurate translation of the relevant passages in the language specified in the PCC, in which case, for purposes of interpretation of the Contract, this translation shall govern.</p>
13	4.2	<p>The following new sub-clause added after 4.1</p> <p>The Supplier shall bear all costs of translation to the governing language and all risks of the accuracy of such translation.</p>
		<b>Applicable Law (GCC 5)</b>
14	5.1	The Applicable Law shall be: Laws of the Islamic Republic of Pakistan.
		<b>Country of Origin (GCC 6)</b>

15	6.1	Country of Origin is .....
<b>Performance Security (or guarantee) (GCC 10)</b>		
16	10.1	The Supplier shall provide a Performance Security of 10% of the Contract Price denominated in the same currency (ies) of the Contract within fourteen (14) days after receipt of Letter of Acceptance.
17	10.3(a)	<p>The Supplier shall provide a Performance Security in the prescribed Form annexed to these Documents in the form of Guarantee from, at the option of the bidder, either (a) bank guarantee from any Scheduled Bank in Pakistan or (b) bank guarantee from a bank located outside Pakistan duly counter-guaranteed by a Scheduled Bank in Pakistan. The cost of complying with requirements of this Sub-Clause shall be borne by the Contractor or (c) insurance guarantee from an insurance company having AA<sup>+</sup> PACRA Rating or acceptable to employer.</p> <p>For avoidance of doubt, the Bank Guarantee issued by a foreign bank, without counter guarantee from a Scheduled Bank in Pakistan shall not be considered as an acceptable Bank Guarantee.</p> <p>The cost of complying with the requirements of this Sub-Clause shall be borne by the Supplier.</p>
18.	10.4	<p>After delivery and acceptance of the Goods, Hundred percent (100%) of the Performance Security (or guarantee) shall be withheld to cover the Supplier's warranty obligations in accordance with <b>GCC Clause 18.2 and SCC Clause-32</b>.</p> <p>The Performance Guarantee will be released after expiry of Warranty/ Defect Liability Period subject to satisfactory performance of delivered material.</p>
<b>Inspections and Tests (GCC 11)</b>		
19.	11.1	<p>Inspection and tests prior to shipment of Goods and at final acceptance are as follows:</p> <p>(a) The Goods shall be subjected to the type, sample and routine tests as described in the Specifications. The Supplier shall provide free of charge all such assistance, instruments, machines, labor and materials as are normally required for carrying out such tests. All reasonable facilities as provided in the specifications or followed by Trade &amp; Industry in general shall have to be offered to the Inspecting officers, by the Supplier at its own expense for carrying out Testing and Inspection.</p> <p>(b) To ensure the manufacture of Goods to be in conformity with Contract requirements, the Supplier shall institute and follow regular procedures for quality assurance during manufacturing. The Supplier shall maintain an independent quality control department, which shall be responsible for enforcing the quality assurance programme. Upon signing of the Contract, the Supplier</p>

		and the Engineer shall establish mutually acceptable quality control and inspection procedure.
20	11.2	<p>(a) Pre-shipment/FAT/ All testing applicable and inspection as per Specification/ requirements attached in Volume-II shall be carried out at the works of manufacturer/ supplier.</p> <p>(b) All work covered by the Contract shall be subject to surveillance, testing and inspection by representatives of Procuring Agency and Engineer. For such purpose the Supplier shall provide free access at all times during manufacturing, assembly and testing to the premises in which the work is being carried out.</p>
21	11.5	<p>Add the following sub-clause-11.5</p> <p>(a) The cost of performing as well as witnessing of Type/Sample/ Routine/Quality Conformance/Factory Acceptance Tests by the Inspectors during foreign inspection shall be borne by the Supplier if such tests are clearly intended by or provided for in the specifications. Witnessing of the tests will cover the expenses of two representatives/inspectors, one nominated by DMD (AD&amp;M) NGC) and 2<sup>nd</sup> from the Engineer (nominated by the concerned DMD) including air ticket from Lahore, Pakistan to the place or places of inspections, boarding &amp; lodging in any A class accommodation, local transportation and daily allowance (including travel time) of 100 € to meet other expenses. The said payment will be made to the inspectors before issuance of test report/Inspection Certificate (IC). In addition to this all the expenses regarding visa stamping (visa fee, 1st class traveling, A-class hoteling etc.) of the Procuring Agency and Engineer inspectors will also be borne by the Supplier. (Not Applicable)</p> <p>(b) In case a part or whole of the Goods being supplied by the Supplier is from within the Procuring Agency's country (Pakistan) the cost of performing as well as witnessing any tests by the inspectors during pre-shipment local inspection shall be borne by the Supplier if such tests are clearly intended by or provided for in the specifications. Witnessing of the tests will cover the expenses of minimum Two (02) Inspectors of Procuring Agency/ NGC, including 1st class traveling (by air or by road depending on the distance from the residing city of inspector to the place or places of inspections), boarding &amp; lodging in any A class accommodation, local transportation and daily allowance (including travel time) of Rs. 15,000 /- per day per person to meet other expenses. The said payment will be made to the inspectors before issuance of Inspection Certificate (IC).</p>
22	11.6	Add the following sub-clause-11.6

		<p>(a) As soon as Goods are ready for inspection the Supplier shall give a notice in writing of at least two (2) months for foreign inspection and one (1) month for local inspection to the inspectors for witnessing such tests with date, time and place.</p> <p>(b) The Procuring Agency will convey the nomination of inspectors within 22 days after receiving inspection call from the Supplier/Contractor.</p> <p>(c) The inspectors shall provide the copies of valid passport and other relevant information within 03 days to the Supplier/Contractor.</p> <p>(d) The Supplier/Contractor shall arrange an Invitation Letter and other relevant documents within 07 days after receipt of the nomination and copies of passport of nominated inspectors for arrangement of Visa.</p> <p>(e) The Visa shall be immediately applied. The delay in issuance of Visa beyond three weeks by embassy shall not be considered on part of Supplier/Contractor. However, delay due to missing information/documents on part of the Supplier/Contractor shall not be compensated.</p> <p>(f) The inspectors shall proceed immediately for inspection within a week's time after issuance of Visa. Any delay in arrangements on part of the Supplier/Contractor shall not be compensated.</p> <p>(g) The inspectors shall submit their report and inspection certificate within 7 days of the inspection. They will clearly mention the validity of the inspection certificate. The validity would be 30 days for foreign supplier and 20 days for local supplier.</p> <p>(h) The supplier / contractor shall be responsible to ship / deliver the material within the validity period of the inspection certificate. In case of expiry, he has either to get extension in validity of the inspection certificate from the Engineer or will re-offer the equipment for inspection.</p> <p>[Note: NGC may at its discretion decide to proceed with 3<sup>rd</sup> party inspection after it's determination/ approval in case of non-availability of inspectors.]</p>
23	11.7	<p>Add the following sub-clause-11.7</p> <p>(a) Two copies of all the Inspection and Tests Reports and certificates including that for quality control shall be supplied to the Engineer. The Engineer shall sign the reports and certificates of such test as have been witnessed.</p> <p>(b) The Procuring Agency's right to inspect, test and, where necessary reject delivery after the Good's arrival in Pakistan shall in no way be limited or waived by reasons of the Goods having</p>

		<p>previously been inspected, tested and passed prior to the Goods shipment from the country of origin.</p> <p>(c) Copies of Certificate of Compliance to Bidding Document provisions as required by the relevant Specification, such as mill certificates are to be supplied to the NGC. Where a certificate of compliance is not called for by the Specification, but a minimum requirement is specified by the Engineer, certificate shall be supplied as if the Specifications had called for the same. For standard stock items, the Supplier's certificate of material is acceptable. The certificate shall be signed by a responsible technical representative of the Supplier having sound engineering background in the related fields.</p> <p>(d) The Supplier shall, if requested provide to the Engineer with un-priced copies of the Supplier's purchase orders for material or approved sub-contracted supply at the time any such orders are placed. The Supplier shall also provide the Engineer with any other relevant information, specifications or other relevant standards, if requested to ensure proper expediting and scheduling of the deliveries.</p> <p>(e) Unless otherwise a waiver for witnessing of tests is issued by the Procuring Agency, no material or Goods shall be shipped/delivered from its point of original manufacturing or final shop assembly before it has been inspected in accordance with Technical Provisions and accepted by the Engineer/ Procuring Agency and released for shipment/delivery</p>
<b>Packing (GCC Clause 12)</b>		
24	12.2	<p>The following <b>SCC</b> shall supplement <b>GCC Clause 12.2:</b></p> <p><b><u>Packing</u></b></p> <ol style="list-style-type: none"> <li>1. In case the Goods are shipped in container(s), each unit shall be so packed that it can be safely transported by road/rail to ultimate destination in the country without disturbing the packing of other items.</li> <li>2. The final packing shall be such that the weight and dimensions of packages are within reasonable limits in order to facilitate handling, storage and transportation.</li> <li>3. The packing, marking, and documentation within and outside the packages shall comply strictly with such special requirements as shall be expressly provided for in the Contract, including additional requirement, if any, and in any subsequent instructions ordered by the Procuring Agency.</li> </ol>

		<p>4. Before any shipment is made, the Supplier shall get the packing detailed drawings approved by the Engineer.</p> <p><b><u>Identification Marking</u></b></p> <ol style="list-style-type: none"> <li>1. All parts/units/components of the Goods shall be plainly die-indented with a number to identify the member, part, unit or component itself and with a letter to indicate the type of Goods in accordance with approved drawings. The identification marking shall be plainly legible and durable and shall be so located that other member, part, unit or component when in its assembled position does not obscure the number or letter. All the marking on ferrous part or unit shall be made before galvanizing.</li> <li>2. Each crate, case, box, package or bundle shall have labels and or tags made from strong waterproof material and marked in indelible and non-fade-able ink securely attached hereto. These labels or tags shall indicate at least the name of the Project, the Consignee and the manufacturer, the type of Goods or component and the quantity it contains so that it can be easily checked upon delivery. A packing list shall be included in each crate or box.</li> <li>3. Each package delivered under the Contract shall be consecutively numbered and shall also be marked with code number or other identification to be approved by NGC so that various components of the Goods, which are shipped, disassembled and which may not be interchangeable can be identified, collected and stored at the Site together. Additional information and or color coding that may reasonably be required by NGC to facilitate identification, shipment to stores or site handling and storage will also be provided.</li> <li>4. All boxes weighing in excess of 500 kilograms shall be adequately marked for straining and lifting. Whenever necessary the boxes shall be provided with lifting hooks attached by means of vertical rods secured to strong bottom supports.</li> </ol> <p>5. <b><u>Container Marking</u></b></p> <p>In addition to labels and marking indicated above all packages, bundles, containers cases or boxes shall be clearly and boldly marked on two opposite sides and on the top and all reels on both sides as follows:</p>
--	--	--

		<p><b>Ultimate Consignee:</b> A-Type Store, 220kV Grid Station, NKLP Lahore. Through Chief Engineer (AM) North, NGC Lahore</p> <p>Final Destination _____ Contract No. _____ Name of Project _____ Weight and Dimension _____ Serial Number _____ Code No. _____ Procuring Agency Inscription "NGC"</p>
	<b>Delivery and Documents (GCC Clause 13)</b>	
25	13.1	<p><b><u>For Goods Supplied from abroad as per incoterms CIF/C&amp;F Karachi:</u></b></p> <p>Upon shipment the foreign supplier shall notify the Procuring Agency and the Insurance Company by fax/cable the full details of the shipment, including Contract number, description of Goods, quantity, the vessel, the bill of lading number and date, port of loading, date of shipment, port of discharge, etc. The Supplier shall submit set of the following non-negotiable documents to the Procuring Agency:</p> <ol style="list-style-type: none"> <li>i) Original and four (04) copies of the Supplier's invoice showing Goods description, quantity, unit price and total amount.</li> <li>ii) Original and four (04) copies of clean on board bill of lading marked "freight prepaid".</li> <li>iii) Original and four (04) copies of the packing list identifying contents of each package.</li> <li>iv) Original and four (04) copies of the Insurance certificate (<i>if applicable</i>)</li> <li>v) Original and four (04) copies of the Manufacturer's/Supplier's warranty certificate.</li> <li>vi) Original and four (04) copies of the Inspection certificate, issued by the Procuring Agency or its designated representative or letter of waiver and the manufacturer's factory inspection report.</li> <li>vii) Original and four (04) copies of the Certificate of origin.</li> <li>viii) Any other document as necessary due to statutory requirements.</li> </ol> <p>The above documents shall be received by the Procuring Agency at least fourteen (14) days before arrival of the Goods at the port or place</p>

		of arrival and, if not received, the Supplier will be responsible for any consequent expenses.
26	13.3	<p><b><u>For Goods from within the Procuring Agency's country as per Incoterms EXW:</u></b></p> <p>The Supplier shall submit the following documents to the Procuring Agency:</p> <ol style="list-style-type: none"> <li>i) Original and four (04) copies of the Supplier's invoice showing the description of the Goods, quantity, unit price, and total amount.</li> <li>ii) Original and four (04) copies of the Delivery Note.</li> <li>iii) Original and four (04) copies of the Manufacturer's or Supplier's warranty certificate.</li> <li>iv) Original and four (04) copies of the Insurance certificate.</li> <li>v) Original and four (04) copies of the Inspection certificate issued by the Procuring Agency/ NGC or its designated representative or letter of waiver, and the manufacturer's factory inspection report; and</li> <li>vi) Original and four (04) copies of the Packing List</li> <li>vii) Original and four (04) copies of the Certificate of Origin.</li> <li>viii) Proof of payment of GST. For the reimbursed of GST, production/provision of the following documents: <ul style="list-style-type: none"> <li>• Invoice in triplicate</li> <li>• Sales Tax Invoice</li> <li>• Sales Tax cum payment challan for the relevant period</li> <li>• Affidavit on non-judicial stamp paper confirming to the effect that sales tax for the above supply is included in the above sales tax cum payment challan.</li> </ul> </li> </ol>
27	13.4	<p>Add the following new sub-clause after 13.3</p> <p>Delivery shall be deemed to have been made:</p> <ol style="list-style-type: none"> <li>a) In case of CIF/C&amp;F Karachi Contract, when an Arrival Notice issued by concerned shipping line on its arrival at Karachi port together with all such documentation as specified at Sub-Clause 13.1 hereof have been furnished.</li> <li>b) In case of Ex-Works Contract, when Delivery Note has been issued together with the invoice(s) and all such other</li> </ol>

		documentation as shall be specified by the Engineer/ Procuring Agency.
	<b>Insurance (GCC Clause 14)</b>	
28	14.1	<p>a) For Goods to be provided from outside the Procuring Agency's Country the Supplier must insure the Goods in the joint names of the Procuring Agency and the Supplier in an amount equal to 110% of CIF price of the Goods from warehouse to warehouse on all risks basis, including but not limiting to war risks, strikes, riot and civil commotion (SRCC), fire, smoke, explosion, terrorism, collision, overturn, derailment, flood, theft or attempted theft.</p> <p>b) For Goods to be provided from within the Procuring Agency's Country, the Supplier must insure the Goods in the joint names of the Procuring Agency and the Supplier in an amount equal to 110% of the FCS price of the Goods from warehouse to warehouse on all risks basis, including but not limiting to war risks, strikes, riot and civil commotion (SRCC), fire, smoke, explosion, terrorism, collision, overturn, derailment, flood, theft or attempted theft.</p>
29	14.2	<p>Add the following sub-clause GCC 14.2</p> <p>The insurance must remain in force for a period of ninety (90) calendar days after receipt of all Goods under the Contract at NGC's designated storage yard, and conducting of insurance survey by the insurer. The Supplier shall arrange and pay for such insurance survey.</p> <p>The insurance shall be affected with National Insurance Company Limited (NICL), Pakistan. The terms of insurance shall be as approved by the Procuring Agency. A draft Insurance Policy shall be submitted by the Supplier within fourteen (14) days following signing of Contract Agreement, for approval by the Procuring Agency.</p> <p>Should a loss be sustained the Supplier shall replace or repair any loss or damage and complete the supplies of Goods in accordance with the Contract as soon as possible after such loss or damage without waiting for the settlement of the insurance claim.</p>
	<b>Related Services (GCC Clause 16)</b>	
30	16.1	Related services to be provided are:

		As per detailed Scope of services, Section-V, Clause SP-01.2.
	<b>Spare Parts (GCC Clause 17)</b>	
31	17.1	Additional spare parts requirements are: Supplier shall carry sufficient inventories to assure ex-stock supply of consumable spares for the Goods. Other spare parts and components shall be supplied as promptly as possible, but in any case, within six (6) months of placing the order and opening the letter of credit.
	<b>Warranty (GCC Clause 18)</b>	
32	18.2	Amend the text of GCC Sub-Clause 18.2 as under:  The warranty shall remain valid for twelve (12) months after delivery of the Goods/ Uniform Items at concerned Store or for eighteen (18) months after entire Goods have been delivered to and accepted at the final destination, whichever period concludes earlier. The new local manufacturers participating in JV with qualified firms or the local subsidiaries of International Manufacturers will be required to submit warranty equal to Two (02) time the aforementioned.  Add the following at the end of GCC Sub Clause 18.2:  Within 14 days after completion of warranty period up to the satisfaction of Procuring Agency and Engineer, the Procuring Agency shall issue Warranty Certificate to the Supplier.
33	18.4	Delete the Clause GCC 18.4 and replace it with the following:  Upon receipt of such notice, the Supplier shall, within the period of 30 days and with all reasonable speed, repair or replace the defective Goods or parts thereof, without costs to the Procuring Agency including the cost of inland delivery of the repaired or replaced Goods or parts from EXW or the port or place of entry to entry to the final destination.
34	18.5	The Supplier shall correct any defects covered by the Warranty within 30 days of being notified by the Procuring Agency of the occurrence of such defects.
	<b>Payment (GCC Clause 19)</b>	
35	19.1	The payment shall be made in the manner and to the extent as mentioned below:

		<ol style="list-style-type: none"> <li>1. For Goods and related services supplied from within the Procuring Agency's Country:</li> <li>2. 100% payment of the material supplied will be made upon submission of the following documents: <ol style="list-style-type: none"> <li>i) Original invoices in triplicate (having NTN) duly verified by quarter concerned.</li> <li>ii) Non-payment certificate to the effect that said payment has not been claimed/ received earlier.</li> <li>iii) Certificate issued by concerned quarters/ A-Type Store that the material/ goods has been successfully delivered as per the schedule of requirement.</li> <li>iv) Income Tax and other Taxes will be deducted at the time of payment.</li> <li>v) GRN issued by the Store.</li> <li>vi) Inspection Certificate (IC).</li> <li>vii) Original and four (04) copies of the Manufacturer's/Supplier's warranty certificate.</li> </ol> </li> <li>3. Partial payment will be allowed on partial delivery of material to the consignee store.</li> </ol>
36		<p>100% Payment against the Contract Price as stated above, shall be paid to foreign Supplier (local Supplier if opted by him) through an irrevocable Letter of Credit to be established by Finance Director (NGC), 2<sup>nd</sup> Floor, Shaheen Complex, Egerton Road, Lahore within Seventy Five (75) days from the date of signing of the Contract Agreement in any scheduled bank in Pakistan in favor of Supplier in a designated bank in his country whereas 100% Payment against the Contract Price shall be directly disbursed to the Pakistani Supplier by the Procuring Agency. (Not Applicable)</p> <ul style="list-style-type: none"> <li>• Within 15 days from issuance of Notification of Award/Letter of Acceptance, the Supplier will submit the following information to the Chief Financial Officer (NGC), Attention: Deputy Manager (L/C), 2<sup>nd</sup> Floor, Shaheen Complex, Egerton Road, Lahore under intimation to the Procuring Agency: (Not Applicable)</li> </ul> <p>a. Signed and Stamped Copy of Notification of Award.</p>

		<p>b. Name &amp; Complete address of Beneficiary.</p> <p>c. Name &amp; complete address of Beneficiary Bank.</p> <p>d. Beneficiary's Bank Account Number &amp; Swift Code.</p> <p>e. Proforma Invoice <b>in original</b> duly signed/stamped including relevant payment terms. (Draft Proforma Invoice is attached as Form-19)</p> <p>f. Freight Breakup.</p> <p>g. No. of Packages.</p> <p>h. Weight and Measurement of goods.</p> <p>i. Port of Shipment.</p> <p>j. Volume.</p> <p>k. Expected Date of Shipment.</p> <p>l. Origin of Goods.</p> <p>m. Delivery Period.</p> <p>n. Relevant H.S Codes to be incorporated in the L/C</p> <p>o. Insurance Cover (if applicable)</p> <ul style="list-style-type: none"> <li>• Draft LC from bank will be provided to Procuring Agency by LC section within 07 days.</li> <li>• Draft will be got vetted from supplier within 07 days, otherwise it will be considered as deemed approved. In this case, LC section will proceed for opening of LC as per Contract Agreement. Any amendment thereof shall be borne by the supplier.</li> </ul> <p>Charges for establishing Letter of Credit and any subsequent charges therein shall be borne by the Supplier.</p>
37	19.4	<p>The currencies for payment shall be:</p> <p>The Supplier shall be paid as per currency(ies) stated in Schedule of Prices except the Pakistani Supplier who will be paid in equivalent Pak Rupees for the foreign currency component at an exchange rate prevailing at the date of Bill of Entry of the imported raw materials for supplying Goods FCS Pakistan basis. The Bill of Entry of the imported raw material shall fall within the Scheduled Delivery Period. Moreover, Bill of Entry issued after Scheduled Delivery Period resulting depreciation in the currency will be on Contractor's part and NGC will recover the same from Contractor's Invoice. The prevalent exchange rate shall be Telegraphic Transfer and On Demand (TT&amp;OD) composite exchange rate (selling) published by National Bank of Pakistan.</p>

	<b>Prices (GCC 20)</b>	
38	20.1	Prices shall be adjusted in accordance with provisions in the Attachment to SCC.  <i>[To be inserted <b>only</b> if price is subject to adjustment.]</i>
	<b>Change Orders (GCC 21)</b>	
39	21.4	Add the following new sub-clause:  The Procuring Agency may increase or decrease the quantities of Goods to the extent of 15% of the Contract Price during currency of the Contract without any change in the unit price or other terms and conditions of the Contract.
	<b>Delays in the Supplier's Performance (GCC 25)</b>	
40	25.2	The existing text is delated and replaced by  If at any time during performance of the Contract, the Supplier or its subcontractor(s) should encounter conditions/events impeding timely delivery of the Goods and performance of Services, the Supplier shall promptly but not later than Twenty-Eight (28) days notify the Procuring Agency in writing of the fact of the delay, its likely duration and its cause(s).  The final request for Extension of Time (EoT) based on notified events and with detailed particulars shall be submitted to the Procuring Agency within Forty-Two (42) days after date of delayed event.  As soon as practicable after receipt of the Supplier's notice, the Procuring Agency shall evaluate the situation and may at its discretion extend the Supplier's time for performance, with or without liquidated damages, in which case the extension shall be ratified by the parties by amendment of Contract.  Any such determinations of the procuring Agency/Purchaser shall be reached/notified within Ninety (90) days from the submission of detailed particulars by the Supplier.
	<b>Liquidated Damages (GCC Clause 26)</b>	
41	26.1	<b>i.</b> In the first line Replace “ <b>Subject to GCC Clause 28</b> ” with “ <b>Except as provided under GCC Clause 28</b> ”.

		<p><b>ii.</b> In the last line Replace “GCC Clause 26” with “GCC Clause 27”</p> <p><b>iii.</b> Applicable percentage of Liquidated Damages is as under:</p> <p>a. The liquidated damages shall be 0.05% of the total Contract Price of Goods per day of delay. The maximum amount of liquidated damages shall be ten percent (10%) of the Contract Price of Goods.</p> <p>b. The Liquidated Damages against Inland Transportation shall be 0.5% of the total Contract price of Inland Transportation per day of delay. The maximum amount of liquidated damages shall be ten percent (10%) of the Contract Price of Inland Transportation. (Not Applicable)</p>
	<b>Procedure for Dispute Resolution (GCC Clause 32)</b>	
42	32.3	<p><b>Dispute Resolution</b></p> <p><b><u>(a) For Contracts to be entered with foreign Contractor/ Service Provider:</u></b></p> <p>All disputes arising in connection with the present Contract shall be finally settled under the Rules of Conciliation and Arbitration of the International Chamber of Commerce by one or more arbitrators appointed in accordance with said Rules.</p> <p><b><u>(b) For Contracts to be entered with nationals of Pakistan:</u></b></p> <p>1. If any dispute of any kind whatsoever shall arise between the Procuring Agency and the Supplier in connection with or arising out of the Contract, including without prejudice to the generality of foregoing, any question regarding its existence, validity, termination and the execution of the Contract– whether during developing phase or after their completion and whether before or after the termination, abandonment or breach of the Contract – the parties shall seek to resolve any such dispute or difference by mutual diligent negotiations in good faith within 7 (seven) days following a notice sent by one Party to the other Party in this regard.</p> <p>2. At future of negotiation the dispute shall be resolved through mediation and mediator shall be appointed with the mutual consent of the both parties.</p>

		<p>3. At the event of failure of mediation to resolve the dispute relating to this contract such dispute shall finally be resolved through binding Arbitration by sole arbitrator in accordance with Arbitration Act 1940. The arbitrator shall be appointed by mutual consent of the both parties. The Arbitration shall take place in Lahore and proceedings will be conducted in English language.</p> <p>4. The cost of the mediation and arbitration shall be shared by the parties in equal proportion however the both parties shall bear their own costs and lawyer's fees regarding their own participation in the mediation and arbitration. However, the Arbitrator may make an award of costs upon the conclusion of the arbitration making any party to the dispute liable to pay the costs of another party to the dispute.</p> <p>5. Arbitration proceedings as mentioned in the above clause regarding resolution of disputes may be commenced prior to, during or after delivery of goods.</p> <p>6. Notwithstanding any reference to the arbitration herein, the parties shall continue to perform their respective obligations under the Contract unless they otherwise agree that the Procuring Agency shall pay the Supplier any monies due to the Supplier.</p>
43	35.1	<p>For notices, the Procuring Agency's address shall be:</p> <p>Attention: Chief Engineer (AM) North, NGC Lahore  NTDC House, 34-Industrial Area Gulberg-III, Lahore-Pakistan  City: Lahore  Country: Pakistan  Telephone No. 92-42-99263023  Email: <a href="mailto:ce.amnl@ntdc.com.pk">ce.amnl@ntdc.com.pk</a></p> <p>The Supplier's address shall be:</p> <p>_____</p> <p>_____</p> <p>_____</p> <p>[To be filled in at the time of signing of Contract.]</p>
	<b>Taxes and Duties (GCC 36)</b>	
44	36.4	<p>Add the following new Sub-Clause after 36.3</p> <p>i. For the Goods to be offered from outside the Procuring Agency's country, all taxes, duties and other leviables in Pakistan on the</p>

		<p>finished Goods shall be paid by the Procuring Agency subject to the condition that material shipped is in the name of NGC and NGC WeBOC is used.</p> <p>ii. For the Goods to be offered from within the Procuring Agency's country, the price shall be inclusive of all taxes, duties and other levies in Pakistan except Sales Tax on the finished Goods. Supplier will submit the invoice inclusive of Sales Tax, Sales Tax shall be charged by the Supplier and payments shall be subject to Withholding Rules specified in 11th Schedule of Sales Tax Act, 1990. Copy of sales tax return will be provided by the supplier. The payments/ reimbursement of Sales Tax will only be made if Invoice is in name of NGC and NGC can claim input from FBR.</p> <p>iii. For the Goods to be transported within the Procuring Agency's country, the price of Inland Transportation shall paid/reimbursed on submission of proof of payment of Sales Tax.</p> <p><b>Note:</b></p> <p>i. Only those local (Pakistan Origin) firms/organizations/companies/suppliers will be eligible to bid who are active taxpayers as per Federal Board of Revenue Data base i.e. Active Taxpayer List (ATL) for both Income Tax &amp; Sales Tax.</p> <p>ii. Foreign firms/organizations/companies/suppliers, (if required) as per law of the country will get them registered from relevant tax authorities after award of the Contract.</p> <p>iii. All payments (including advance) will be subject to withholding Taxes as per Income Tax Ordinance, 2001/International Tax Treaty &amp; Sales Tax Act. 1990, further, in case of local firms payments shall made only to those entities appearing in Active Taxpayer List (ATL) for both Income Tax &amp; Sales Tax.</p> <p>iv. Advance Payment Guarantee and Performance Guarantee will be exclusive of Indirect Taxes.</p>
--	--	---

## **SECTION IX: BILL OF QUANTITIES**

**FORM-2B**  
**PRICE SCHEDULE: GOODS MANUFACTURED OUTSIDE PAKISTAN,**  
**ALREADY IMPORTED**

Sr No.	Description of Material	Quantity (Nos./ Pairs)	Unit Price (PKR)	Total Rates (PKR)
1	Shirt Sky Blue	944 Nos.		
2	Trouser Navy Blue	944 Nos.		
3	Shoes/Boot DMS Leather long.	472 Pairs		
4	Beret Cap (Maroon)	472 Nos.		
5	Cap Badge Metal NGC	472 Nos.		
6	Arm Shield	472 Nos.		
7	Night Jacket Navy Blue with NGC Security Monogram	47 Nos.		
8	Jersey Blue Full Sleeves	472 Nos.		
9	Vest Cotton Half Sleeves (Round Neck)	944 Nos.		
10	Socks Nylon Black	944 Pairs		
11	Badge of Rank Sergeant	91 Nos.		
12	Nylon Belt Black with plate with NGC Monogram	472 Nos.		
13	Shoulder Title Metal	472 Pairs		
14	Rank of Inspector	40 Pairs		
15	Rain Suit	472 Nos.		
16	Gloves Woolen Navy Blue	472 Pairs		
17	Cap Comforter	472 Nos.		
18	Lanyard Maroon Whistle	472 Nos.		
			<b>Total</b>	
			<b>18% GST</b>	
			<b>Grand Total</b>	

**Notes:**

1. The applicable specifications are to be read carefully before filling up the Schedule of Prices.
2. Non-returnable samples of all BoQ items must be submitted to office of Chief Engineer (AM) North, NGC Lahore, before the time of bid submission on E-PADS. Non-submission of samples may result in rejection of bid.
3. In case of discrepancy, between unit price and total, the unit price will prevail.
4. The Delivery will be on FCS Basis to A-Type Store, 220kV Grid Station NGC NKLP Lahore.

**Signature and Seal of the Bidder**

**FORM-2C****PRICE SCHEDULE FOR DOMESTIC GOODS MANUFACTURED WITHIN PAKISTAN**

<b>Sr No.</b>	<b>Description of Material</b>	<b>Quantity (Nos.)</b>	<b>Unit Price (PKR)</b>	<b>Total Rates (PKR)</b>
1	Shirt Sky Blue	944 Nos.		
2	Trouser Navy Blue	944 Nos.		
3	Shoes/Boot DMS Leather long.	472 Pairs		
4	Beret Cap (Maroon)	472 Nos.		
5	Cap Badge Metal NGC	472 Nos.		
6	Arm Shield	472 Nos.		
7	Night Jacket Navy Blue with NGC Security Monogram	47 Nos.		
8	Jersey Blue Full Sleeves	472 Nos.		
9	Vest Cotton Half Sleeves (Round Neck)	944 Nos.		
10	Socks Nylon Black	944 Pairs		
11	Badge of Rank Sergeant	91 Nos.		
12	Nylon Belt Black with plate with NGC Monogram	472 Nos.		
13	Shoulder Title Metal	472 Pairs		
14	Rank of Inspector	40 Pairs		
15	Rain Suit	472 Nos.		
16	Gloves Woolen Navy Blue	472 Pairs		
17	Cap Comforter	472 Nos.		
18	Lanyard Maroon Whistle	472 Nos.		
			<b>Total</b>	
			<b>18% GST</b>	
			<b>Grand Total</b>	

**Notes:**

1. The applicable specifications are to be read carefully before filling up the Schedule of Prices.
2. Non-returnable samples of all BoQ items must be submitted to office of Chief Engineer (AM) North, NGC Lahore, before the time of bid submission on E-PADS. Non-submission of samples may result in rejection of bid.
3. In case of discrepancy, between unit price and total, the unit price will prevail.
4. The Delivery will be on FCS Basis to A-Type Store, 220kV Grid Station NGC NKLP Lahore.

**Signature and Seal of the Bidder**

## **SECTION X: CONTRACT FORMS**

**(INTEGRITY PACT)**

**DECLARATION OF FEES, COMMISSION AND BROKERAGE ETC.  
PAYABLE BY THE SUPPLIERS OF GOODS, SERVICES & WORKS IN  
CONTRACTS WORTH RS. 10.00 MILLION OR MORE**

Contract No. \_\_\_\_\_

Dated

\_\_\_\_\_   
Contract Value: \_\_\_\_\_

Contract Title: \_\_\_\_\_

..... [Name of Bidder] hereby declares that it has not obtained or induced the procurement of any contract, right, interest, privilege or other obligation or benefit from Government of Pakistan (GoP) or any administrative subdivision or agency thereof or any other entity owned or controlled by GoP through any corrupt business practice.

Without limiting the generality of the foregoing, [Name of Bidder] represents and warrants that it has fully declared the brokerage, commission, fees etc. paid or payable to anyone and not given or agreed to give and shall not give or agree to give to anyone within or outside Pakistan either directly or indirectly through any natural or juridical person, including its affiliate, agent, associate, broker, consultant, director, promoter, shareholder, sponsor or subsidiary, any commission, gratification, bribe, finder’s fee or kickback, whether described as consultation fee or otherwise, with the object of obtaining or inducing the procurement of a contract, right, interest, privilege or other obligation or benefit in whatsoever form from GoP, except that which has been expressly declared pursuant hereto.

[Name of Bidder] certifies that it has made and will make full disclosure of all agreements and arrangements with all persons in respect of or related to the transaction with GoP and has not taken any action or will not take any action to circumvent the above declaration, representation or warranty.

[Name of Bidder] accepts full responsibility and strict liability for making any false declaration, not making full disclosure, misrepresenting facts or taking any action likely to defeat the purpose of this declaration, representation and warranty. It agrees that any contract, right, interest, privilege or other obligation or benefit obtained or procured as aforesaid shall, without prejudice to any other rights and remedies available to GoP under any law, contract or other instrument, be voidable at the option of GoP.

Notwithstanding any rights and remedies exercised by GoP in this regard, [Name of Bidder] agrees to indemnify GoP for any loss or damage incurred by it on account of its corrupt business practices and further pay compensation to GoP in an amount equivalent to ten time the sum of any commission, gratification, bribe, finder’s fee or kickback given by [Name of Bidder] as

aforesaid for the purpose of obtaining or inducing the procurement of any contract, right, interest, privilege or other obligation or benefit in whatsoever form from GoP.

Name of Purchaser: .....

Name of Bidder: .....

Signature: .....

Signature: .....

[Seal]

[Seal]

**FORM OF PERFORMANCE SECURITY  
(Bank Guarantee)**

Guarantee No. \_\_\_\_\_  
Executed on \_\_\_\_\_  
Expiry date \_\_\_\_\_  
Guarantee Amount \_\_\_\_\_

[Letter by the Guarantor to the Procuring Agency]

Name \_\_\_\_\_ of \_\_\_\_\_ Guarantor \_\_\_\_\_ (Bank) \_\_\_\_\_ with \_\_\_\_\_ address: \_\_\_\_\_

\_\_\_\_\_  
(Scheduled Bank in Pakistan)

Name of Principal (Supplier or Contractor) with address: \_\_\_\_\_

Guaranteed Amount/Sum of Security against services/works/contracts (express in words and figures) \_\_\_\_\_.

(Hereinafter referred to as the "Bank/Guarantor" which expression shall be deemed to include its respective successors-in-interest and assignee and shall be deemed as well to include any financial institutions which may subsequently become the party).

Letter \_\_\_\_\_ of \_\_\_\_\_ Acceptance \_\_\_\_\_ No. \_\_\_\_\_  
Dated \_\_\_\_\_

KNOW ALL MEN BY THESE PRESENTS, that in pursuance of the terms of the Bidding Documents and above said Letter of Acceptance (hereinafter called the Documents) and at the request of the said Principal we, the Guarantor above named, are held and firmly bound unto the \_\_\_\_\_ (hereinafter called the Procuring Agency) in the Guaranteed Amount/Sum stated above for the payment of which sum well and truly to be made to the said Procuring Agency, we bind ourselves, our heirs executors, administrators and successors, jointly and severally, firmly by these presents.

THE CONDITION OF THIS OBLIGATION IS SUCH that whereas the Principal has accepted the Procuring Agency's above said Letter of Acceptance for \_\_\_\_\_ (Name of Contract) for the \_\_\_\_\_ (Project detail etc.)

NOW THEREFORE, if the Principal (Supplier or Contractor as applicable) shall well and truly perform and fulfill all the undertakings, covenants, terms and conditions of the said Documents to which reference is here made for all purposes during the original terms of the said Documents and any extensions thereof that may be granted by the Procuring Agency, with or without notice to the Guarantor, which notice is, hereby, waived and shall also well and truly perform and fulfill all the undertakings, covenants terms and conditions of the Contract and of any and all modifications of said Documents the may hereafter be made, notice of which modifications to

the Guarantor being hereby waived, then, this obligation to be void; otherwise to remain in full force and virtue till the issuance of Warranty Certificate in accordance with Clause \_\_\_\_, Warranty, of Conditions of Contract.

Our total liability under this Guarantee is limited to the Sum stated herein above and it is a condition of any liability attaching to us under this Guarantee that the claim for payment in writing shall be received by us within the validity period of this Guarantee which Sum we irrevocably and unconditionally agree to pay immediately upon any request for payment or demand received on which/the end \_\_ ( date), failing which we shall be discharged of our liability, if any, under this Guarantee.

We, \_\_\_\_\_ (the Guarantor), waiving all objections and defenses under the Contract, do hereby unconditionally, irrevocably and independently guarantee and undertake to pay to the Procuring Agency without protest, demur, delay and without reference, notice or recourse to contractor to any other person upon the Procuring Agency 's first written demand without cavil or arguments and without requiring the Procuring Agency to prove or to show grounds or reasons for such demand and hereby expressly waive all rights to deny our obligation to the Procuring Agency irrespective of any dispute, difference, ongoing litigation, arbitration proceeding or disagreement between \_\_\_\_ and \_\_\_\_, or contestations by any other party or person, any Sum or Sums up to the amount stated above, against the Procuring Agency's written declaration that the Principal has refused or failed to perform the obligations under the Contract which payment will be effected by the Guarantor to Procuring Agency's designated Bank & Account Number.

PROVIDED ALSO THAT the Procuring Agency shall be the sole, exclusive and final judge for deciding whether the Principal has duly performed his obligations under the Contract or has defaulted in fulfilling said obligations and any written demand to the Guarantor made in the manners specified above shall be conclusive evidence of failure to comply with, \_\_\_\_ and the Guarantor shall pay without objection any Sum or Sums up to the amount stated above upon first written demand from the Procuring Agency forthwith and without any reference to the Principal or any other person.

The Guarantee shall be a continuing security and shall remain in operation until \_\_\_\_ after the expiration, termination of the contract or any extension thereto.

PROVIDED FURTHER THAT until the expiry date of the Guarantee, the Procuring Agency shall be entitled to present written demand(s) to the Guarantor in the manner specified above for any amount up to the aggregate Guaranteed Amount. The Guarantor agrees that nothing in this Guarantee shall bar the Procuring Agency from presenting multiple written demands to the Guarantor, provided that the amount claimed in the written demand(s) shall not collectively exceed the aggregate Guaranteed Amount.

IN WITNESS, WHEREOF, the above-bounden Guarantor has executed this Instrument under its seal on the date indicated above, the name and; corporate seal of the Guarantor being hereto

affixed and these presents duly signed by its undersigned representative, pursuant to authority of its governing body.

Witness:

Guarantor (Bank)

1. \_\_\_\_\_  
\_\_\_\_\_  
Corporate Secretary (Seal)

Signature \_\_\_\_\_  
Name \_\_\_\_\_

Title \_\_\_\_\_

2. \_\_\_\_\_  
\_\_\_\_\_  
Name, Title & Address

\_\_\_\_\_  
Corporate Guarantor (Seal)

**FORM OF CONTRACT AGREEMENT**

THIS AGREEMENT made on the \_\_\_\_\_ day of \_\_\_\_\_, 20\_\_\_\_, between \_\_\_\_\_ of \_\_\_\_\_ (hereinafter “the Procuring Agency”), of the one part, and \_\_\_\_\_ of \_\_\_\_\_ (hereinafter called “the Supplier”), of the other part:

WHEREAS the Procuring Agency invited bids for certain Goods viz., \_\_\_\_\_ and has accepted a Bid by the Supplier for the supply of those Goods in the sum of \_\_\_\_\_ (hereinafter called “the Contract Price”).

NOW THIS AGREEMENT WITNESSETH AS FOLLOWS:

1. In this Agreement words and expressions shall have the same meanings as are respectively assigned to them in the Conditions of Contract hereinafter referred to.
2. The following documents shall be deemed to form and be read and construed as part of this Agreement, viz.:
  - (a) The Procuring Agency’s Notification of Award of Contract to the Supplier (Letter of Acceptance);
  - (b) The completed Forms of Bid;
  - (c) Priced Schedules of Prices submitted by the Supplier;
  - (d) The Particular Conditions of Contract, Part-II;
  - (e) The General Conditions of Contract, Part-I;
  - (f) Form No. 4 to 13;
  - (g) Specifications: Technical Provisions;
  - (h) Specifications: Special Provisions;
  - (i) Specifications: Drawings; and
  - (j) Any other item

This Agreement shall prevail over all other Contract documents. In the event of any discrepancy or inconsistency within the Contract Documents, then the documents shall prevail in the order listed above.

3. In consideration of the payments to be made by the Procuring Agency to the Supplier as indicated in this Agreement, the Supplier hereby covenants with the Procuring Agency to provide the Goods and to remedy defects therein in conformity in all respects with the provisions of the Contract.
4. The Procuring Agency hereby covenants to pay the Supplier in consideration of the provision of the Goods and the remedying of defects therein, the Contract Price or such other sum as may become payable under the provisions of the Contract at the times and in the manner prescribed by the Contract.

IN WITNESS, WHEREOF the parties hereto have caused this Agreement to be executed in two (02) identical counterparts each of which shall be deemed as the original, in accordance with the laws of Islamic Republic of Pakistan, on the day, month and year indicated above.

Signed by, for and on behalf of

\_\_\_\_\_  
(the Supplier)

Signed by, for and on behalf of

\_\_\_\_\_  
(the Procuring Agency)

Signed, Sealed and Delivered in the presence of:

\_\_\_\_\_  
(Name, Title and Seal)

\_\_\_\_\_  
(Name, Title and Seal)

**FORM OF ADVANCE PAYMENT SECURITY (Not Applicable)**

Date: \_\_\_\_\_

Contract Name and No. \_\_\_\_\_

\_\_\_\_\_

To:

\_\_\_\_\_

In accordance with the payment provision included in the Contract, in relation to advance payments, \_\_\_\_\_ (hereinafter called "the Supplier or Contractor") shall deposit with the Procuring Agency a security consisting of \_\_\_\_\_, to guarantee its proper and faithful performance of the obligations imposed by said Clause of the Contract, in the amount of \_\_\_\_\_.

We, the undersigned (Bank Details) \_\_\_\_\_, legally domiciled in \_\_\_\_\_ (hereinafter "the Guarantor"), as instructed by the Supplier or Contractor waiving all rights of objections and defense arising from principal debt hereby agree unconditionally and irrevocably to guarantee as primary obligor and not as surety merely, the payment to the Procuring Agency on its first demand without whatsoever right of objection on our part and without its first claim to the Supplier, in the amount not exceeding \_\_\_\_\_.

Additionally, the claims under this Advance Payment Security/Guarantee shall be honored if dated and received not later than \_\_\_\_ ( date).

Provided that the payment of any Sum by the bank shall be made free and clear of withholding of any kind such as without limitation \_\_\_\_ taxes and fees.

This security shall remain valid and in full effect from the date of the advance payment received by the Supplier under the Contract until twenty-eight (28) days following completion of delivery/works/services basis as certified by the Procuring Agency.

Name \_\_\_\_\_

In the Capacity of \_\_\_\_\_

Signed \_\_\_\_\_

Duly authorized to sign the security for and on behalf of \_\_\_\_\_

Date \_\_\_\_\_

## **VOLUME-II**

# **SPECIFICATIONS**

## General Specification Sheet for Uniform Items/ Liveries

1	Shirt Sky Blue (Nos.)	(Ready to use) Good Quality Fabric, High Quality Stitching, Sky Blue Color or subject to sample approval
2	Trouser Navy Blue (Nos.)	(Ready to use) Good Quality Fabric, High Quality Stitching, Navy Blue Color or subject to sample approval
3	Shoes/Boot DMS Leather long. (Pair)	Ankle Boot, Black Color, Original Leather (Good Quality) or subject to sample approval
4	Beret Cap (Maroon) (Nos.)	Cap with Black Piping, Maroon Color (Good Quality) or subject to sample approval
5	Cap Badge Metal NGC (Nos.)	Metallic Badge of NGC Logo, Good Quality of Material and Badge Color or subject to sample approval
6	Arm Shield (Nos.)	Arm Shield/ Badge of NGC Logo, Good Quality or subject to sample approval
7	Night Jacket Navy Blue with NGC Security Monogram (Nos.)	Reflective Warm Jacket with NGC Security Monogram (Good Quality - Double Flees for winter), High Quality Stitching, Color Navy Blue or subject to sample approval
8	Jersey Blue Full Sleeves (Nos.)	Jersey Woolen Full Sleeves (Good Quality), 2 Front Pockets, Color Navy Blue or subject to sample approval
9	Vest Cotton Half Sleeves (Round Neck) (Nos.)	Vest of Cotton Fabric (Good Quality), High Quality Stitching, Shrinkage Control, Half Sleeves, Round Neck or subject to sample approval
10	Socks Nylon Black (Pair)	Black Color, Nylon Fabric (Good Quality), Double Knit or subject to sample approval
11	Badge of Rank Sergeant (Nos.)	Badge of Rank Sergeant, Red Color with Two Black Lines, Good Quality or subject to sample approval
12	Nylon Belt Black with plate with NGC Monogram (Nos.)	Black Color Belt with Buckle Plate with NGC Monogram, Nylon Material (Good Quality) or subject to sample approval
13	Shoulder Title Metal (Pair)	Shoulder Metallic Badge written as "NGC Security" - Good Quality of Material and Badge Color or subject to sample approval
14	Rank of Inspector (Pair)	Metallic Badge of Rank of Inspector - Good Quality of Material and Badge Color or subject to sample approval
15	Rain suit (Nos.)	Long Rain Coat, Parachute Material (Good Quality), Navy Blue Color or subject to sample approval
16	Gloves Woolen Navy Blue (Pair)	Navy Blue Color, Woolen Fabric (Good Quality) or subject to sample approval
17	Cap Comforter (Nos.)	Navy Blue Color, Woolen Fabric (Good Quality) or subject to sample approval
18	Lane Yard Maroon Whistle (Nos.)	Steel Whistle with Lanyard (Maroon), Good Quality or subject to sample approval

## Technical Data Cloth Shirting (Sky Blue)

1. Weight per Sq Mtr : 200 gms  $\pm$ 10 gms
2. Material Composition
  - a. Polyester : 65%  $\pm$  5%
  - b. Cotton : 35% (Balance)
3. Thread per inch
  - a. Warp : 76  $\pm$  2
  - b. Weft : 60  $\pm$  2
4. Shrinkage (Maximum)

Warp	:	2 %
Weft	:	2 %
5. Nature of Dyes : Permanant
6. Scouring Loss (Maximum) : 1%
7. Crease Recovery : Wrinkle Resistant
8. Shade : Sky Blue (As per standard pattern)
9. Feel & Finish : Mercerized
10. The cloth shall be woven with the yarn uniformity spun and twisted, free from neps, knots and other spinning defects like contamination with fly (fibers) of other material causing development of slubs / streaks of different shade in cloth.

Stitching as per Sample and sizes.

## SHIRT SKY BLUE

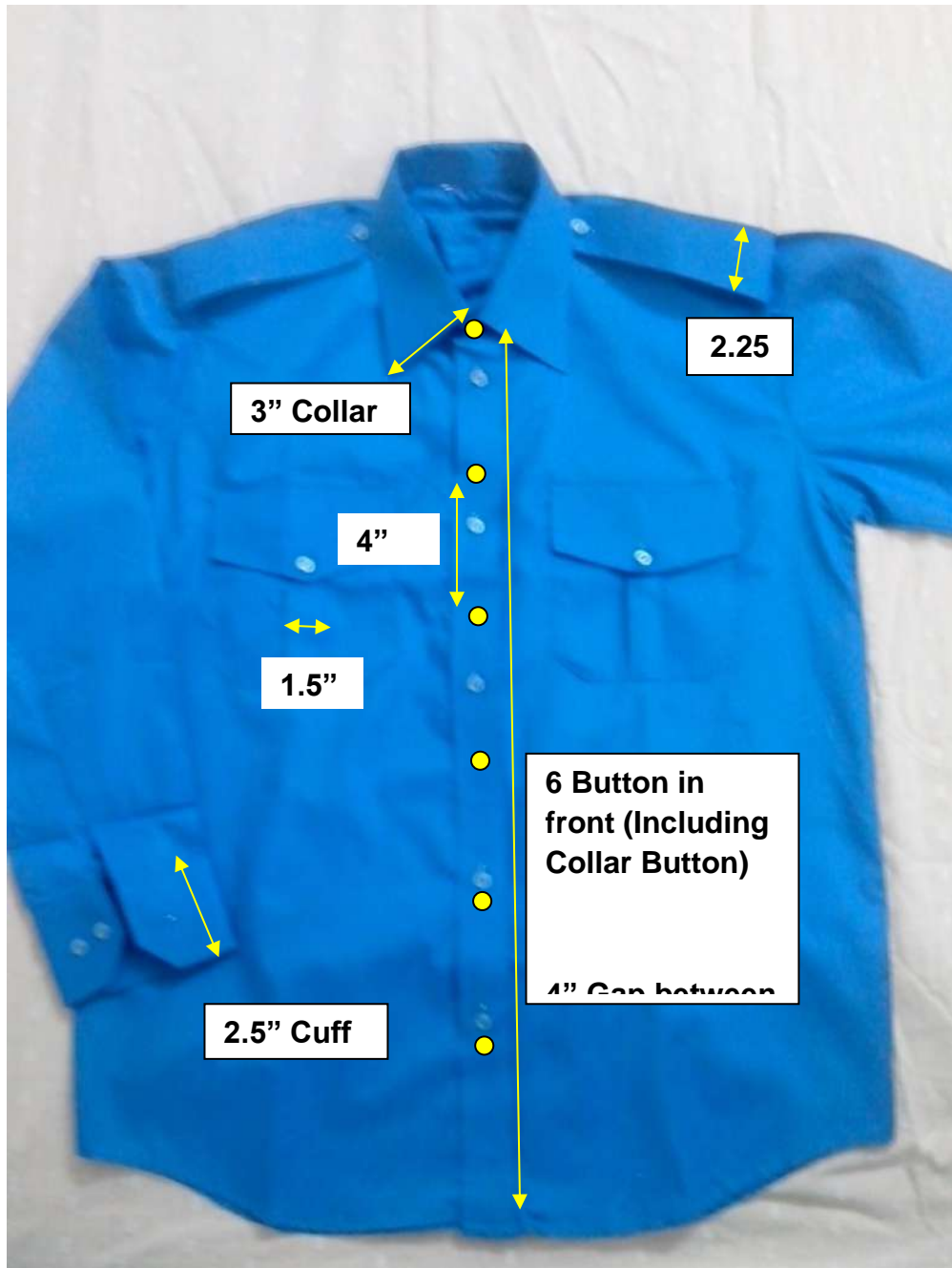

**CUFF**

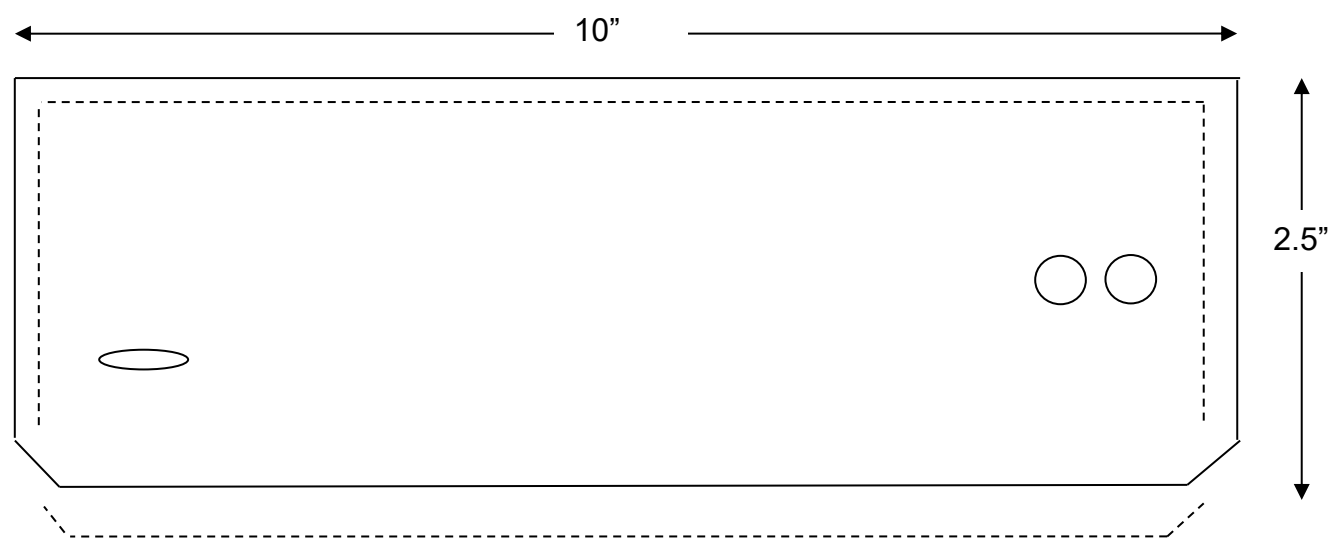

**COLLAR**

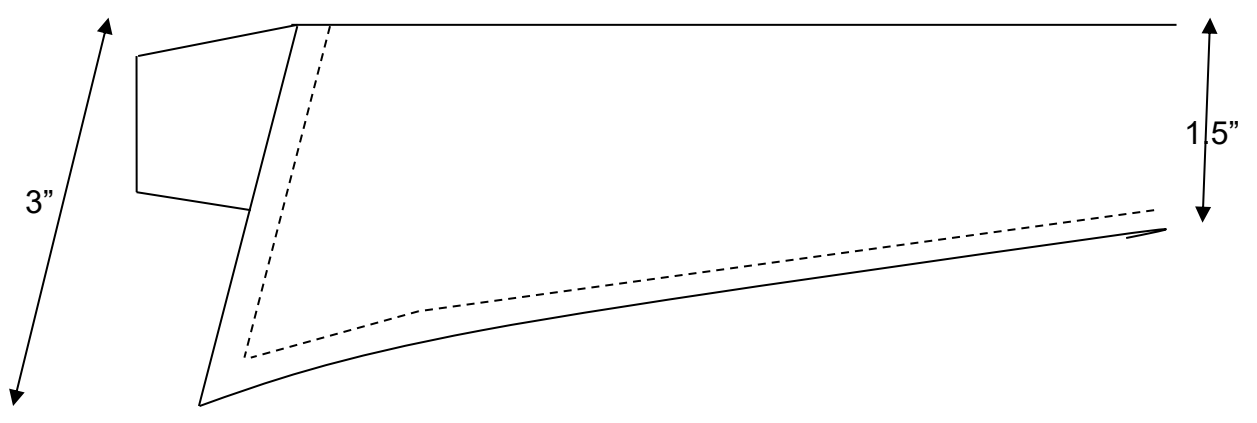

# SHIRT POCKETS

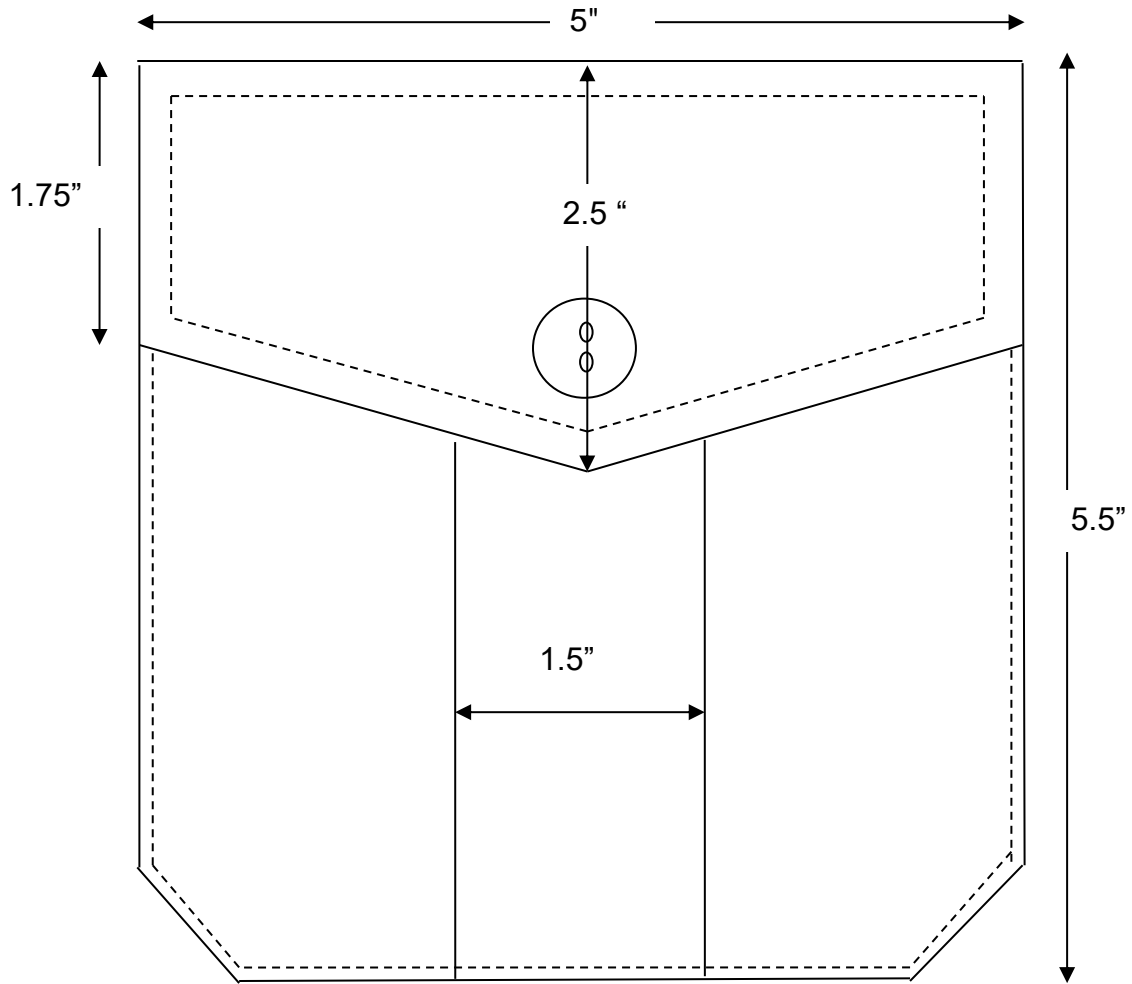

## Technical Data Cloth Trousers (Navy Blue)

1. Width (Including selvedge) : 57"±1"
2. Wt/Sq Mtr : 250 gms ±10 gms
3. Material Composition
  - Polyester : 65% ± 5%
  - Cotton : 35% (Balance)
4. Weave : 1/1 Twill
5. Thread per inch
  - Warp : 82 ± 2
  - Weft : 68 ± 2
6. Shrinkage (Maximum)
  - Warp : 2 %
  - Weft : 2 %
7. Nature of Dyes
  - Polyester : Disperse
  - Cotton : Vat
8. Scouring Loss (Maximum) : 1%
9. Crease Recovery
  - Warp / Weft : Not less than 75%
10. Shade : Navy Blue
11. Special Finish : Easy Care (Wrinkle Free)
12. Ironing :
  - a. The cloth should not bleed color on wet cloth during ironing.
  - b. The cloth should not shine with ironing
13. The cloth shall be woven with the yarn uniformity spun and twisted, free from neps, knots and other spinning defects like contamination with fly (fibers) of other material causing development of slubs / streaks of different shade in cloth.

## TROUSER DARK/NAVY BLUE

- Fly with 3 Buttons
- Belt 2.00" Wide
- Belt Loop 4.25" Long
- NOTE: All the Stitching must be over-locked

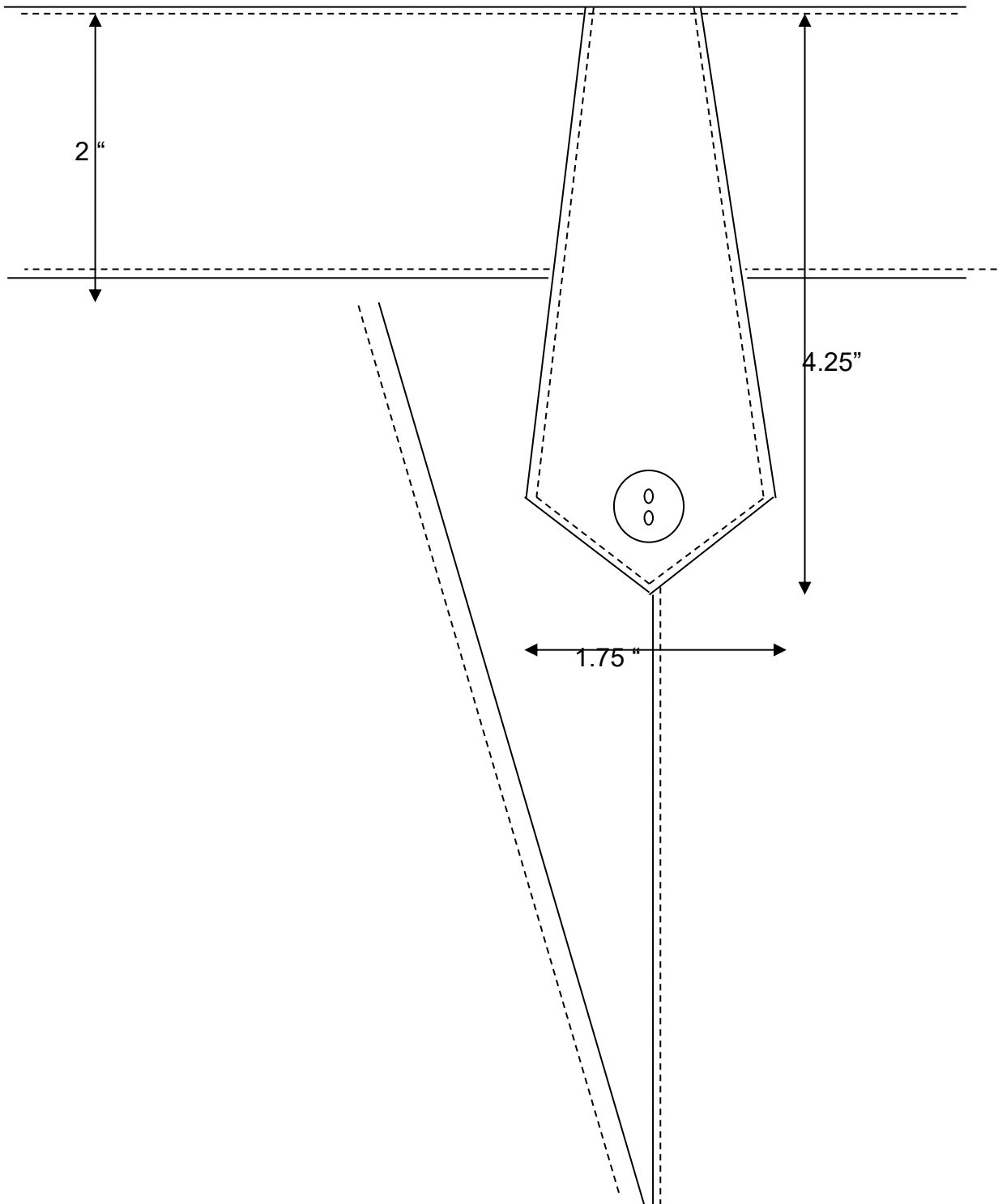

TROUSER DARK/NAVY BLUE

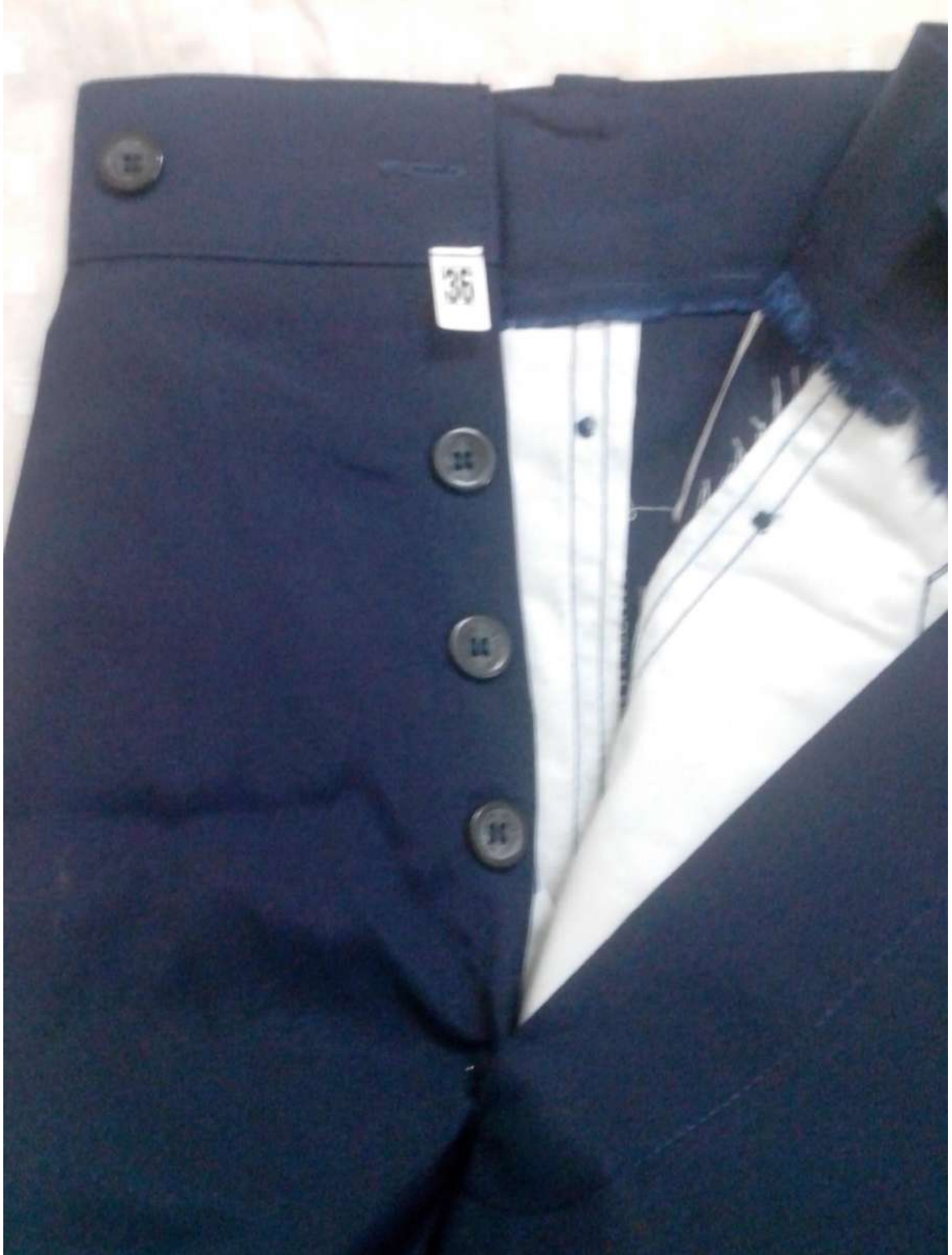

**SHOES BLACK LEATHER (ANKLE HEIGHT)**

**Ankle Boot Leather Black**



**ARM SHEILD (NGC)**

**Diameter : 2.5”**

**Safety Pin for Wearing on Sleeve of the Shirt/Jersey**



**JACKET (NAVY BLUE)**



**(Large Size)**

**JACKET (NAVY BLUE)**



← 26" Width →

## **TECHNICAL DATA JERSEY WOOLEN PULLOVER (NAVY BLUE)**

### **(Army Pattern)**

1. Composition of material : Wool = 60% ± 3%  
Acrylic = 32% ± 2%  
Polyester = 08% (Balance)
2. Composition of Blended material : Wool =70%  
Acrylic =30%
3. Type of Yarn : Double
4. Quality of Wool : 64 (21.1 – 22.5 microns)
5. Quality of Acrylic : 3D Regular
6. Knitting : As per sample
7. Shade : Navy Blue
8. Shoulder Flaps : The Jersey should have two shoulder Straps 5cm at the base tapering to 3.75cm at the end.
9. Buttons : Button round (13 mm dia) plastic blue grey with sewing holes.
10. The Jersey shall have a "V" shaped neck fitted with 2/2 rib attached by linking machine and not over locked.
11. The sleeve shall have re-enforcement patch at elbow position of shape and design in the drawing and made from 100% polyester cloth. The patch shall be stitched with double rows of stitching all round.
12. The Jersey have two pocket flaps having a button hole and button. The flaps shall be made from knitted fabric of the same material and lined with 100% polyester cloth.
13. The average number of ribs / 10 inches should be 32 to 33.
14. The Dyed Jersey shall have a light fastness of at least class V (five).
15. The Dyed Jersey shall show no change in shade or any sign of staining on to the attached pieces of Nylon and Woolen material when subjected to washing.
16. The seams and joints shall withstand stretching in all directions to the full extent of the knitted fabric without breaking and allowing the loops of fabric to run or distort.

## JERSEY WOOLLEN NAVY BLUE

**Note: 10 " Blue Zeen Cloth on Elbow of Jersey Sleeves**

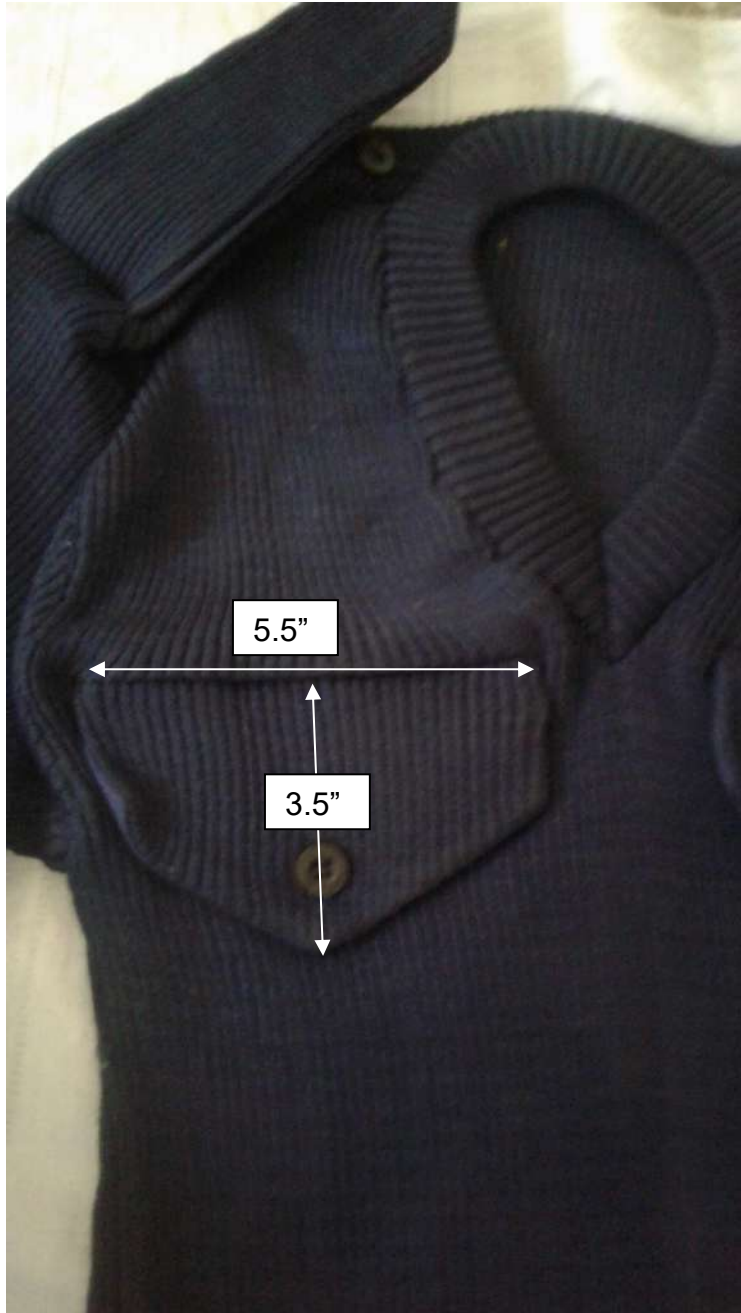

## SOCKS NYLON (BLACK) DOUBLE KNITT

**NOTE: Size as per Sample**

**Weight = 28 g (Single) 56 g (Pair)**



**Beret Maroon**



RANK SERGEANT



## **Technical Data Vest Cotton H/Sleeves (White)**

1. Weight per Sq Mtr : 130 gms  $\pm$ 10 gms
2. Material Composition : Cotton 100%
3. Count : 32 ECC
4. Yarn Twist (TPI) : 22  $\pm$  1
5. Thread per inch
  - a. Wales : 37  $\pm$  2
  - b. Course : 45  $\pm$  2
6. Shrinkage (Maximum)
  - a. Length : 20 mm
  - b. Chest : 20 mm
7. Sewing Cotton : 4 cord each single0
8. Finishing : Full Bleached

## TECHNICAL DATA

### RAIN COAT WATERPROOF (Imported) (NAVY BLUE)

1. Material : Polyester or Nylon Fabric coated with Silicon or PU from inside.
2. Weight : 150 to 170 GSM
3. Seam : Rugged Heat Sealed



**RAIN COAT WATERPROOF (Imported) (NAVY BLUE)**



## TECHNICAL DATA

### CAP COMFORTER WOOLEN (NAVY BLUE)

1. Material : Wool 100%  $\pm$  2
2. Quality of Wool : 60 S to 64 S
3. Stitching Thread : Nyon/Polyester

**NOTE :** Weave design as per approved sample

**Length = 30 Inch**

**Width = 10 Inch (Unstretched)**

**Weave = 9 line per inch**



**Wiegth = 127.5 g (Total)**

**LANYARD (MAROON) WITH WHISTLE (STEEL)**



## NYLON BELT BLACK WITH METAL PLATE - NGC

Length	=	52"
Front Plate	=	3 " x 2.5" with NGC Metal Badge (Chrom Plated)
Eyelet Holes	=	20
Buckle Design	=	As per Sample
Weight Front		
Plate+Badge	=	71 g



**SHOULDER TITLE – NGC (SILVER METALLIC)**

**Width = 2.00"**

**Height = 0.80"**

**Weight = 6.6 g (Single)**



## CAP BADGE – NGC (SILVER METALLIC)

**Height = 1.60''**

**Width = 1.40''**

**Weight = 16 g**



**RANK INSPECTOR (METALLIC)**



**GLOVES WOOLEN (NAVY BLUE)**



**NTDC'S SOP FOR BLACKLISTING OF  
CONTRACTORS**



## NATIONAL TRANSMISSION & DESPATCH CO. LTD

**Company Secretary**

No. NTDC/CS/191-207

Dated: 27 - 02 - 2019

### NOTIFICATION

#### Approval for revision of SoP for Blacklisting

Ref: This office notification No.NTDC/CS/1728-42 dated 25.07.2017.

The Board of Directors National Transmission & Despatch Company Limited (NTDC) in its 150<sup>th</sup> meeting held on 25.02.2019 against agenda item No.10 has unanimously resolved and approved the revised/amended SoP for Blacklisting.

  
Ijaz Ahmad  
Company Secretary

#### Copy to:

1. Managing Director.
2. Dy. Managing Director (AD&M).
3. Dy. Managing Director (P&E).
4. All General Managers.
5. Chief Financial Officer.
6. Chief Law Officer.
7. Chief Internal Auditor.
8. Chief Information System.

A copy of the revised SoP for Blacklisting is enclosed.



## NATIONAL TRANSMISSION & DESPATCH CO. LTD

**Company Secretary**

No. NTDC/CS/ 444-60

Dated: 29 - 03 - 2019

### CORRIGENDUM

#### Approval for revision of SoP for Blacklisting

In continuation to this office Notification No.NTDC/CS/191-207 dated 27.02.2019 on the subject matter, the designation of Chief Engineer (Reliability Assessment) being a committee member in Chapter No.3 under Clause 3.1 at page # 7 of the approved revised/amended SoP for Blacklisting may be read as 'Chief Engineer (Reliability Compliance)'.  
'

#### Note:

- All other contents of the notification will remain intact.

Ijaz Ahmad

**Company Secretary**

#### Copy to:

1. Managing Director.
2. Dy. Managing Director (AD&M).
3. Dy. Managing Director (P&E).
4. All General Managers.
5. Chief Financial Officer.
6. Chief Law Officer.
7. Chief Internal Auditor.
8. Chief Information System.

# **NATIONAL TRANSMISSION AND DESPATCH COMPANY LIMITED (NTDC)**

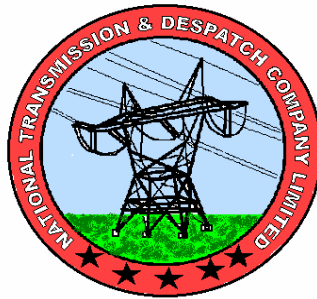

## **REVISED SOP FOR BLACKLISTING**

**(As on 25.02.2019)**

# Table of Contents

CHAPTER NO.1.....	3
1.1 INTRODUCTION .....	3
1.2 EXTENT OF APPLICATION.....	3
CHAPTER NO. 2.....	5
2. REASONS OF BLACKLISTING .....	5
CHAPTER NO. 3.....	7
3. FORMULATION OF “NTDC’S RIGHTS PROTECTION COMMITTEE” .....	7
CHAPTER NO. 4.....	8
4.1 PROCEDURE FOR BLACKLISTING .....	8
4.2 INITIATION OF AN ACTION.....	8
4.3 DECISION.....	8
4.4 COMMUNICATION OF DECISION .....	9
4.5 PERIOD OF DEBARMENT FOR BLACKLISTED FIRMS .....	9
Note: All the penalties given herein above will be in addition to the consequences already agreed by the parties in the contract or any other document and other remedies provided under the law. ....	
4.6 ACTION AFTER FIRMS ARE PLACED ON BLACKLISTING ....	9
4.7 EFFECTIVENESS.....	10
APPENDIX-1 .....	11
APPENDIX-2 .....	13
REFERENCES .....	

# CHAPTER NO.1

## 1.1 INTRODUCTION

The main objectives of any procurement process are transparency, economy, fairness and efficiency so that value for money is achieved.

Blacklisting is one of the most effective tools used in the struggle against inefficiencies and corruption in connection with public procurement. In addition, it serves as a major deterrent against any material breach of contract and further ensures the timely execution of projects by holding delinquent persons accountable.

Rule-19 “Blacklisting of suppliers and contractors” of the Public Procurement Rules, 2004 (hereinafter “**PPRA Rules**”) stipulates that;

*“The procuring agencies shall specify a mechanism and manner to permanently or temporarily bar, from participating in their respective procurement proceedings, suppliers and contractors who either consistently fail to provide satisfactory performances or are found to be indulging in corrupt or fraudulent practices. Such barring action shall be duly publicized and communicated to the Authority: Provided that any supplier or contractor who is to be blacklisted shall be accorded adequate opportunity of being heard.”*

In the light of the Clause above, this SOP has been drafted for procurements made by NTDC.

Any capitalised terms and abbreviations used in this SOP which are not defined herein shall have the meanings given to them in Public Procurement Regulatory Authority Ordinance, 2002 (hereinafter “**PPRA Ordinance**”) and PPRA Rules.

## 1.2 EXTENT OF APPLICATION

- i. The procedure shall be applicable and remain in force, along with any amendments thereto, within NTDC until any clear instructions or guidelines are imparted by the Government through PPRA, PEC, or any other competent forum.
- ii. The procedure shall also be applicable on the pre-qualified firms.
- iii. The procedure shall be applicable on any “Person”, which for the purposes of this SOP shall *interalia* include suppliers, bidders, contractors, consultants, firms, individuals, and organizations transacting business with NTDC.
- iv. Wherever any provision of this SOP shall be in conflict with provisions of any applicable guidelines of donor agencies, or any other applicable Statute / Law or Rule enforced at the time in Pakistan, the provisions of such applicable guidelines, laws, or rules shall prevail.

- v. This SOP shall become a part of the future Bidding Documents and the person(s) will submit an Undertaking along-with his bid that he has read and accepts the provisions of this SOP. Non-submission of an Undertaking may result in rejection of his bid. The said Undertaking will subsequently become part of the Contract Agreement as well.

## CHAPTER NO. 2

### 2. REASONS OF BLACKLISTING

2.1 The causes and reasons to be taken into consideration for Debarment / Blacklisting of any person are given as under:

#### 2.1.1 Pre- Award Stage:

The following shall be considered, *interalia*, the causes / reasons for initiating proceedings under this SOP at the Pre-Award Stage:

- i. Indulging in Corrupt, Fraudulent as well as Collusive practices.
- ii. Submission of false and spurious documents, making false statements, making frivolous complaints and allegations to gain undue advantage.
- iii. Commission of embezzlement, criminal breach of trust, theft, cheating, forgery, bribery, falsification or destruction of records, receiving stolen property, false use of trademark, securing fraudulent registration, giving false evidence, furnishing of false information of serious nature.
- iv. Submission of false bid security or infringement of documents to get undue monetary or any other benefit.
- v. Breach of confidentiality of evaluation process as mentioned in Appendix-1 based on illegal access or in any way to get undue benefit or to provide benefit or to frustrate the bidding/evaluation process. This will also include attempts to sabotage the bidding process directly or indirectly.

#### 2.1.2 Post- Award Stage:

The following shall be considered, *interalia*, the causes / reasons for initiating proceedings under this SOP at the Post-Award Stage:-

- i. Extraordinary delay in signing or refusal to accept the Notification of Award and/or the contract without any cogent reason.
- ii. Misconduct, i.e., failure to proceed with the signed contract, withdrawal of commitments, quoting an unreasonably and unfairly low financial offer and subsequently withdrawing such an offer, frustrating the evaluation/bidding process and not responding to written communication in a reasonable time.
- iii. Causes mentioned in Clause 2.1.1 (i, ii & iii) above.
- iv. Submission of fake / frivolous or mutilated Performance Guarantee or Advance Payment Guarantee etc.

- v. Non-satisfactory performance as mentioned in Appendix-2 during the execution of the contract.
- vi. Non-performance or Breach of provisions / clauses of the contract agreements.
- vii. Notwithstanding the warranty/defect liability period, any defect in a product, equipment, plant, facility or services rendered that may subsequently surface during field operations within 5 years of its commissioning.
- viii. Failure to honour obligations within warranty period or defect liability period as defined in the contract.

### **2.1.3 Other Causes**

- i. The person is blacklisted by any Government department in Pakistan, or it is established that the firm is involved in any kind of corruption or corrupt practices anywhere in the world.
- ii. Violations of provisions / instructions set down in the Bidding Documents.
- iii. Any attempt / activity to malign or bring NTDC into disrepute and harm its interest(s).
- iv. Person(s) blacklisted by International Financial Institutions (donor agencies) will be liable to be blacklisted after receipt of confirmation from the donor agencies without any further proceeding.
- v. Any other cause deemed just and appropriate by NTDC in the given circumstances.

#### **Note:**

- (1) If above mentioned causes occur either on part of the principal bidder or the local agent, both shall be considered for blacklisting / debarment.
- (2) The authorization of the foreign bidder to local agent shall contain his complete particulars including the name of the company, name of the owner, National Tax number (NTN), CNIC (Computerized National Identity Card) No. etc. In case, the said information is found to be missing, even after calling for the same within a reasonable time, the authority letter shall not be accepted.
- (3) The Bidding Documents shall be issued against original authority letter or in case of scanned copy, the email of the foreign bidder shall be enclosed. However, at the time of bidding, the original authority letter shall be attached with the bid. In the absence of the same, the bid shall be rejected.

## CHAPTER NO. 3

### 3. FORMULATION OF “NTDC’S RIGHTS PROTECTION COMMITTEE”

3.1 A permanent Committee namely “NTDC’s Rights Protection Committee (**RPC or Committee**)” comprising of the following members shall examine the justification of the reasons given by the Project Authority prior to blacklisting / debarment of any firm/supplier/contractor/ individual.

- |  |          |
|--|----------|
| • General Manager (Performance Assessment) NTDC    | Convener |
| • Chief Engineer (Reliability Compliance) NTDC     | Member   |
| • Representative of the Chief Law Officer’s Office | Member   |

Depending upon the nature of the case, the Committee may consult or appoint / nominate additional members from within NTDC with the approval of Managing Director (NTDC), provided that the Committee consists of an odd number of individuals as per spirit of Rule 48(1) of the PPRA Rules. Independence of any additional members shall be ensured while making the selection of such additional members. Furthermore, the aforementioned RPC shall also be authorized to seek external expert advice as and when required.

## **CHAPTER NO. 4**

### **4.1 PROCEDURE FOR BLACKLISTING**

Upon receipt of or obtaining information and/or knowledge that any person(s) is involved in practices mentioned in Chapter-2 earlier, the concerned Project Authority / formation shall promptly formulate its recommendations and submit through MD NTDC to NTDC RPC along with its findings, details of charges and documentary evidences to initiate proceedings under this SOP.

### **4.2 INITIATION OF AN ACTION**

- (i) Within a period of 15 days after receiving the recommendations of Blacklisting / Debarment from the concerned Project Authority, the Convener of the Committee shall issue a Show Cause Notice (“**Notice**”) thereby informing the Person about the alleged charges and shall provide an opportunity to the defend said charges within a time period of 15 (fifteen) days.
- (ii) The person(s) shall be accorded adequate opportunity of hearing in order to defend the charges within the given timelines.
- (iii) The Notice to the Person shall be sent at the mailing/postal address as provided under the Contract or any other address provided by way of subsequent written communication by the Person. The non-receipt of the Notice due to incorrect / change in mailing address without any written communication shall not be attributable to NTDC. In case of non-receipt of any reply from the accused person within the formulated time, but not less than the time given in 4.2 (i) above, the Committee shall have the right to proceed on Ex-parte basis.

### **4.3 DECISION**

- i. The committee shall hold an independent inquiry/investigation as the case may be, and, which may include site visits and interviews with the parties concerned. The Committee shall complete the entire inquiry/investigation, preferably within a period of 30 days after receipt of response from the person against whom proceedings under this SOP have been initiated and shall present the report to the MD NTDC.

- ii. If required, the Committee may report the case to an appropriate law enforcement agency depending upon the nature of the case for detailed investigations with the prior approval of Managing Director (NTDC).
- iii. The person against whom proceedings have been initiated under this SOP shall not proceed for arbitration/litigation during the proceedings for blacklisting.

#### **4.4 COMMUNICATION OF DECISION**

After recommendation for blacklisting by “NTDC’s Rights Protection Committee (RPC)”, the person concerned shall be informed within 10 days of such decision. The decision of the Committee will be notified on NTDC’s and PPRA’s websites and shall also be conveyed to Pakistan Engineering Council. Blacklisting of firms shall also be conveyed by circular to other Government Departments. All other relevant procuring agencies including PEPCO, DISCOs, and WAPDA, etc., will also be informed simultaneously.

#### **4.5 PERIOD OF DEBARMENT FOR BLACKLISTED FIRMS**

- (i) The Blacklisting on the grounds and reasons specified herein above in Chapter No. 2 shall be for a reasonable specified period of time and as a general rule of prudence, the period may not exceed three years, except in cases where debarment/blacklisting has been done by any other government department or an International Financial Institution (Donor Agency).
- (ii) In case the person has been blacklisted by the government department or the International Financial Institution (donor agency), the period of blacklisting/debarment shall be for a maximum period of 3 years or the time period for which the concerned government department/International Financial Institution (Donor Agency) debarred the contractor (whichever is higher).

#### **4.6 ACTION AFTER PERSONS ARE PLACED ON BLACKLISTING LIST.**

- i. The decision of blacklisting will be immediately circulated to all concerned as mentioned at Clause 4.4 above.
- ii. In case of a contract already awarded to a person which has been blacklisted and termination is either not possible or not feasible, the concerned Project Authority may proceed in this case to complete the contract with the approval of Competent Authority.
- iii. The blacklisted person shall stand disqualified from bidding from the date of decision against them. Any pending bids shall also stand rejected. If a contract has

already been awarded to person, it shall be voidable at the option of NTDC as per 4.6 (ii) above.

- iv. A separate register or data base will be maintained for blacklisted firms indicating reasons and period.

#### **4.7 EFFECTIVENESS**

These guidelines / SOP or any amendments thereof shall take effect immediately after its approval from Board of Directors of NTDC.

## **APPENDIX-1**

### **PROCESS TO DEAL WITH FRIVOLOUS COMPLAINTS**

It has been frequently observed that after opening of tenders, the bidders start to influence the evaluation process. Such attempts result in delay in finalizing of award of contract and cause financial loss to the National exchequer. The evaluation process is confidential till publication of award of contract process.

Provision of guidelines of international donor agencies and PPRA provides sufficient opportunity to bidders for redressal of their grievances. Hence, the attempts made by the bidders during evaluation process or thereafter to influence the contract award decisions fall under the definition of corrupt and fraudulent practices. Therefore, during bidding stage, the following mechanism shall be adopted in case of receipt of any frivolous complaint from the bidder.

- i. Anonymous complaints shall not be entertained.
- ii. The Procuring Agency reserves the right to call for an affidavit from the complainant verifying the truthfulness and correctness of the contents of the complaint.
- iii. The notice of displeasure and explanation will be immediately sent to those persons who lodge frivolous complaint(s) during the evaluation process.
  - iii (a) If the person itself or through its agent or any third party does not refrain from making frivolous complaints in the same tender or any other tender, an official warning will be sent and their case may be sent to “NTDC’s Rights Protection Committee” which may analyse the situation and suggest action including the rejection of the bid of the complainant. However, Project Authority may reject the bid even in first instance depending upon nature of the case or provision of the Bidding Documents.
  - iii (b) If the same person itself or through its agent or any third party lodges a frivolous complaint in another tender floating in parallel before decision of the Grievance Committee, its bid will straight forwardly be rejected by the project authority. It may also be debarred to participate in the next tender for a minimum period of six months under intimation to the Grievance Committee and MD NTDC.
- iv. In order to monitor the record of the persons, a data base will be maintained at NTDC’s website and the offices of the project authorities regarding such persons who consistently lodge frivolous complaints during the evaluation process by making clandestine access to confidential record and hamper the award of contract process.

**NOTE: It is clarified that the process provided above in Appendix 1 is to discourage anonymous and frivolous complaints only, and does not bar any person feeling aggrieved by any act of the procuring agency from lodging a genuine complaint/grievance as provided under Rule 48 of the PPRA Rules, 2004.**

## **APPENDIX-2**

### **GUIDELINES FOR EVALUATION OF PERFORMANCE OF CONTRACTORS**

- i. After signing of the contract, the Project authority (or the Consultant / Engineer) must monitor and evaluate the Contractor's performance, that is, whether the Contractor is fulfilling his obligations based on the terms of the contract and plans that were developed and agreed upon with the Project authority at the time of signing of contract or during kick-off meetings..
- ii. Though the performance evaluation of any person is an on-going process, which takes place throughout the duration of the contract and also during the Defect Liability / Warranty Period, nevertheless, a person's Performance Evaluation Report may be prepared for the consumption and benefit of the procuring agency or for any other purpose at the completion of the project, as the case may be.
- iii. The performance evaluation report shall be prepared for all contracts of more than Rs. 100 million. When based on the Evaluation Report, the performance of a person is non-satisfactory, the procuring agency may initiate the case for blacklisting of the person in accordance with the terms of this SOP. For the avoidance of doubt, consistent failure to provide satisfactory performance shall also include performances in a single or multiple contracts executed or being executed by the same person, as the case may be.
- iv. In case of any extra-ordinary delay in performance of a single contract of vital and critical importance, the procuring agency shall have the right to initiate proceedings under this SOP and/or avail any other remedy provided under the law which may *interalia* include: termination of the contract, recovery of losses, debarring the person from participation in future tenders. The procuring agency shall be the sole judge to determine the projects of vital or critical importance.
- v. In case of ordinary delay in performance in 2 consecutive contracts within a period of 3 years, the procuring agency shall have the right to initiate proceedings under this SOP and/or avail any other remedy provided under the law which may *interalia* include: termination of the contract, recovery of losses, debarring the person from participation in future tenders.
- vi. The proceedings under this SOP shall not prejudice any other rights and/or remedies available to the procuring agency under the contract documents and/or any other law in force.