

# NATIONAL UNIVERSITY OF TECHNOLOGY



## BIDDING DOCUMENT

**FOR**

**Provision of ICT Services at Main Campus,  
NUTECH Islamabad through PSDP**

**TENDER REFERENCE NO: 106/PMO/ICT/01**

**Project Management Office**

**April 2026**

**NATIONAL UNIVERSITY OF TECHNOLOGY**

Karnal Sher Khan Shaheed Road, Sector I-12, Islamabad – 44000

Telephone No. +92-51-5476809 Ext: 219, 234

Email: [info@nutech.edu.pk](mailto:info@nutech.edu.pk)



**NATIONAL UNIVERSITY OF TECHNOLOGY (NUTECH),  
ISLAMABAD**

**NOTICE INVITING TENDER (NIT)**

1. National University of Technology (NUTECH) invites electronic proposals through **EPADS** from the well-established and reputed ICT firms registered with SECP / FBR and an active taxpayer for following work:-

<b>Sr</b>	<b>Tender Ref No.</b>	<b>Description of Work</b>	<b>Bid Security</b>
1	106/PMO/ICT/01	Provision of ICT Services at Main Campus, NUTECH Islamabad Through PSDP	2,000,000/-

2. Bidding Document containing scope of work, detailed terms and conditions for submission of proposals, method of procurement (**Single Stage Two Envelop Procedure**), bid security, bid validity, opening of proposals, evaluation & qualification criteria, specifications, requirements etc. are available for the registered bidders on **EPADS - PPRA**. Non-compliance with any form of bidding document will result in the rejection of respective bid.
3. Pre-Bid meeting will be held on **22<sup>nd</sup> April, 2026** at **1100 hours** at the address mentioned below.
4. The Technical bids must be submitted online by using **EPADS** on or before **4<sup>th</sup> May 2026 till 1100 hours**. Bids will be opened on the same day at **1145 hours**.
5. All the firms participating through EPADS will be bound to submit their Original bid security in the shape of Pay order / Demand Draft as mentioned above in the favor of **“Development Project Security Account”** with letterheads in the office of the undersigned not later than **1100 hours** on **4<sup>th</sup> May 2026**.
6. This advertisement is also available on PPRA / NUTECH website.



**Project Management Office (PMO)**  
National University of Technology, (NUTECH)  
Main IJP Road, Sector I-12, Islamabad  
Ph: 051-5476768 Ext 219, 234  
[pm.office@nutech.edu.pk](mailto:pm.office@nutech.edu.pk)



# **INSTRUCTIONS TO BIDDERS (IB)**



## INSTRUCTIONS TO BIDDERS

### A. GENERAL

- IB.1 Scope of Bid**
- 1.1 The Employer as defined in the **Bidding Data** hereinafter called “the Employer” wishes to receive bids for the construction and completion of works as described in these Bidding Documents, and summarized in the **Bidding Data** hereinafter referred to as the “Works”.
- 1.2 The successful Bidder will be expected to complete the Works within the time specified in the **Bidding Data**.
- IB.2 Source of Funds**
- 2.1 The Employer has applied for/received a funding from the source(s) in various currencies towards the cost of the project specified in the **Bidding Data** and it is intended that part of the proceeds of this funding will be applied to eligible payments under the Contract for which these Bidding Documents are issued.
- IB.3 Eligible Bidders**
- 3.1 This Invitation for Bids is open to all Bidders meeting the following requirements at the time of submission of Bids and thereafter:
- Duly eligible for this bidding process;
  - Duly licensed by the Pakistan Engineering Council (PEC) in the category relevant to the value of the Works in the relevant field of specialization.  
  
However, a Foreign Constructor can submit provisional licence with its Bid but the Foreign Constructor will be required to submit standard licence after award of Contract and before start of work.  
  
Foreign Constructor shall not be eligible to participate in bidding individually. Foreign Constructor shall enter into joint venture with Pakistani Constructor registered with the Pakistan Engineering Council in equivalent/compatible category and submit the joint venture agreement to the Employer before participating in bidding in accordance with PEC Construction and Operation of Engineering Works Bye-laws, 1987;
  - Pakistani Constructor must be on Active Taxpayer List of the Federal Board of Revenue and provincial revenue authority/ board where applicable; and
  - All partners constituting the Bidder including proposed subcontractors do not appear in the list of debarred/blacklisted firms and individuals on the websites of PEC and Federal & Provincial Procurement Regulatory Authorities and have not been declared debarred/blacklisted by foreign country, international organizations or other foreign institutions.



- IB.4 Eligible Materials, Equipment and Services**
- 4.1 All materials, equipment and services to be supplied under this Contract shall have their origin in eligible countries described under paragraph 4.4 hereunder.
- 4.2 For purpose of this Clause, “origin” means the place where the Goods are mined, grown or produced or from where the ancillary services are supplied. Goods are produced when, through manufacturing, processing or substantial and major assembling of components, a commercially recognized product results that is substantially different in basic characteristics or in purpose or utility from its components.
- 4.3 The origin of Goods and Services is distinct from the nationality of the Bidder.
- 4.4 Eligible countries to participate in this bidding process are those which have been notified by Ministry of Interior, Government of Pakistan as Business Friendly Countries (BVL); information can be accessed through following link:  
<http://www.dgip.gov.pk/Files/Visa%20Categories.aspx#L>
- IB.5 One Bid per Bidder**
- 5.1 Each Bidder shall submit only one Bid either by himself, or as a partner in a joint venture. A Bidder who submits or participates in more than one Bid (other than alternatives pursuant to Clause IB.17) will be disqualified.
- IB.6 Site Visit**
- 6.1 The Bidders are advised to visit and examine the Site of Works and its surroundings and obtain for themselves on their own responsibility all information that may be necessary for preparing the Bid and entering into a contract for construction of the Works. All cost in this respect shall be at the Bidder’s own expense.
- 1.1 The Bidders and any of their personnel or agents will be granted permission by the Employer to enter upon his premises and lands for the purpose of such inspection, but only upon the express condition that the Bidders, their personnel and agents, will release and indemnify the Employer, his personnel and agents from and against all liability in respect thereof and will be responsible for death or personal injury, loss of or damage to property and any other loss, damage, costs and expenses incurred as a result of such inspection.
- B. BIDDING DOCUMENTS**
- IB.7 Contents of Bidding Documents**
- 7.1 The Bidding Documents, in addition to Invitation for Bids, are those stated below and should be read in conjunction with any Addenda issued in accordance with Clause IB.9:



1. Instructions to Bidders;
2. Bidding Data;
3. Evaluation Criteria and Qualification Updating Forms;
4. General Conditions (GC);
5. Particular Conditions (PC);
6. Specifications (SP) (if any);
7. Letter of Bid;
8. Schedules to Bid;
9. Standard Forms:
  - (i) Form of Bid Security;
  - (ii) Letter of Acceptance;
  - (iii) Form of Contract Agreement;
  - (iv) Form of Performance Security;
  - (v) Form of Mobilization Advance Guarantee;
10. Drawings.

7.2 The Bidders are expected to examine carefully the contents of all the above documents. Failure to comply with the requirements of Bid submission will be at the Bidder's own risk. Pursuant to Clause IB.26, bids which are not substantially responsive to the requirements of the Bidding Documents will be rejected.

**IB.8 Clarification of Bidding Documents, Pre-Bid Meeting**

- 8.1 Any prospective Bidder requiring any clarification(s) in respect of the Bidding Documents may notify the Employer in writing at the Employer's address indicated in the Invitation for Bids. The Employer will respond to any request for clarification which he receives earlier than the period specified in the **Bidding Data**, prior to the deadline for submission of bids.
- 8.2 Copies of the Employer's response will be forwarded to all purchasers of the Bidding Documents, including a description of the enquiry but without identifying its source.
- 8.3 The Employer may, on his own or at the request of any prospective Bidder(s), hold a pre-bid meeting to clarify issues and to answer any questions on matters related to the Bidding Documents. The date, time and venue of pre-bid meeting, if convened, are as stipulated in the **Bidding Data**. All prospective Bidders or their authorized representatives shall be invited to attend such a pre-bid meeting.
- 8.4 The Bidders are requested to submit questions, if any, in writing so as to reach the Employer not later than seven (7) days before the proposed pre-bid meeting.



- IB.9 Amendment of Bidding Documents**
- 8.5 Minutes of the pre-bid meeting, including the text of the questions raised and the replies given, will be transmitted without delay to all purchasers of the Bidding Documents. Any modification of the Bidding Documents listed in Sub-Clause IB.7.1 hereof which may become necessary as a result of the pre-bid meeting shall be made by the Employer exclusively through the issue of an Addendum pursuant to Clause IB.9 and not through the minutes of the pre-bid meeting.
- 8.6 Absence at the pre-bid meeting will not be a cause for disqualification of a Bidder.
- 9.1 At any time prior to the deadline for submission of bids, the Employer may, for any reason, whether at his own initiative or in response to a clarification requested by a prospective Bidder, modify the Bidding Documents by issuing addendum.
- 9.2 Any addendum thus issued shall be part of the Bidding Documents listed in Sub-Clause IB.7.1 hereof and shall be communicated in writing to all purchasers of the Bidding Documents. Prospective Bidders shall acknowledge receipt of each addendum in writing to the Employer.
- 9.3 Such addendum shall be issued not later than number of days prior to the deadline for submission of bids, specified in the **Bidding Data**. To afford prospective Bidders reasonable time in which to take an addendum into account in preparing their bids, the Employer may extend the deadline for submission of bids in accordance with Clause IB.20.
- IB.10 Cost of Bidding**
- C. PREPARATION OF BIDS**
- IB.11 Language of Bid**
- 1.1 The Bidders shall bear all costs associated with the preparation and submission of their respective bids and the Employer will in no case be responsible or liable for those costs, regardless of the conduct or outcome of the bidding process.
- 11.1 The Bid and all correspondence and documents related to the Bid exchanged by a Bidder and the Employer shall be in the Bid language stipulated in the **Bidding Data** and Particular Conditions of Contract. Supporting documents and printed literature furnished by the Bidders may be in any other language provided the same are accompanied by duly certified translation of the relevant parts in the Bid language, in which case, for purposes of evaluation of the bid, the translation in Bid language shall prevail.
- IB.12 Documents Comprising the Bid**
- 12.1 Each Bidder shall:
- (a) submit duly filled in, signed and stamped Letter of Bid and completed Schedules to Bid as required, including priced Bill of Quantities, in accordance with Clause IB.18 hereof;



- (b) submit Bid Security in accordance with Clause IB.16 hereof;
  - (c) submit alternative proposal, if permissible in accordance with Clause IB.17;
  - (d) submit a written power of attorney authorizing the signatory of the Bid to act for and on behalf of the Bidder. The name and position held by each person signing the authorization must be typed or printed below the signature;
  - (e) submit the Qualification Updating Forms duly filled in, signed and stamped along with requisite attachments, to establish that the Bidder continues to meet the Eligibility and Qualification Criteria set out in the Pre-Qualification Documents and as provided in the Section "Evaluation Criteria and Qualification Updating Forms";
  - (f) furnish a technical proposal taking into account the various Schedules to Bid, specially the following:
    - Schedule-C to Bid, Proposed Construction Schedule;
    - Schedule-D to Bid, Method of Performing the Work;
    - Schedule-E to Bid, List of Major Equipment;
    - Schedule-F to Bid, Organization Chart for Supervisory Staff;and other pertinent information, such as mobilization programme, etc.
- 12.2 Bids submitted by a joint venture of two (2) or more firms specified in **Bidding Data**, shall comply with the following requirements:
- (a) the bid, and in case of a successful bid, the Form of Contract Agreement shall be signed by all members so as to be legally binding on all partners;
  - (b) one of the joint venture partners shall be nominated as being in-charge; and this authorization shall be evidenced by submitting a power of attorney signed by legally authorized signatories of all the joint venture partners;
  - (c) the partner-in-charge shall always be duly authorized to deal with the Employer regarding all matters related with and/or incidental to the execution of Works as per the terms and Conditions of Contract and in this regard to incur any and all liabilities, receive instructions, give binding undertakings and receive payments on behalf of the joint venture;
  - (d) all partners of the joint venture shall at all times and under all circumstances be liable jointly and severally for the execution of the Contract in accordance with the



Contract terms and a statement to this effect shall be included in the authorization mentioned under Sub-Para(b) above as well as in the Letter of Bid and in the Form of Contract Agreement (in case of a successful bid); and

- (e) a copy of the agreement entered into by the joint venture partners shall be submitted with the bid stating the conditions under which it will function, its period of duration, the persons authorized to represent and obligate it and which persons will be directly responsible for due performance of the Contract and can give valid receipts on behalf of the joint venture, the proportionate participation and corresponding duties & responsibilities of the several firms forming the joint venture, and any other information necessary to permit a full appraisal of its functioning. No amendments/modifications whatsoever in the joint venture agreement shall be agreed to between the joint venture partners without prior written consent of the Employer.

12.3 Bidders shall also submit proposals of work methods and schedule, in sufficient detail to demonstrate the adequacy of the Bidders' proposals to meet the technical specifications and the completion time referred to in Sub-Clause IB.1.2 hereof.

**IB.13 Bid Prices**

13.1 The price and discount if any quoted by the Bidders in the Letter of Bid and in the Bill of Quantity shall conform to the requirement specified below:

13.2 The Bidder shall quote any discounts and the methodology for their application.

13.3 If bids are being invited for individual lots (contracts) or for any combination of lots, the Bidders can offer discounts for the individual lots (contracts) as well as for award of more than one Contract and shall specify in their bid.

13.4 Unless stated otherwise in the Bidding Documents, the Contract shall be for the whole of the Works as described in Sub-Clause IB.1.1 hereof, based on the unit rates and/or prices.

13.5 The Bidders shall fill in rates and prices for all items of the Works described in the Bill of Quantities. Items against which no rate or price is entered by a Bidder will not be paid for by the Employer when executed and shall be deemed covered by rates and prices for other items in the Bill of Quantities.

13.6 All duties, taxes and other levies payable by the Contractor under the Contract, or for any other cause, as on the date 28 days prior to the deadline for submission of bids shall be included in the rates and prices and the total Bid Price submitted by a Bidder.



Additional/reduced duties, taxes and levies due to subsequent additions or changes in legislation shall be reimbursed/deducted as per Sub Clause 13.6 [*Adjustment for Changes in Laws*] of the Conditions of Contract.

- 13.7 The rates and prices quoted by the Bidders are subject to adjustment during the performance of the Contract in accordance with the provisions of Sub-Clause 13.7 [*Adjustments for Changes in Cost*] of the General Conditions of Contract. The Bidders shall furnish the prescribed information for the price adjustment formulae in Schedule-A to Bid, and shall submit with their bids such other requisite supporting information if required under the said Schedule.
- IB.14 Currencies of Bid and Payment**
- 14.1 The unit rates and the prices shall be quoted by the Bidder entirely PKR.
- A Bidder expecting to incur expenditures in other currencies for inputs to the Works supplied from outside the Employer's country (referred to as the "Foreign Currency Requirements") shall indicate in Table III of Schedule-A to Bid the proportion of the Bid Price (excluding Provisional Sums) needed by him for the payment of such Foreign Currency Requirements; in such case the unit rates and the prices shall be quoted by the Bidder in Equivalent PKR.
- 14.2 The rates of exchange to be used by the Bidder for currency conversion shall be the TT Selling Rates published or authorized by the State Bank of Pakistan prevailing on the date twenty eight (28) days prior to the deadline for submission of bids. Such rates shall be notified by the Employer not later than fourteen (14) days prior to the deadline for submission of Bids.
- For the purpose of payments, the exchange rates used in Bid preparation shall apply for the duration of the Contract.
- IB.15 Bid Validity**
- 15.1 Bids shall remain valid for the period stipulated in the **Bidding Data** after the date of Bid Opening specified in Clause IB.23.
- 15.2 In exceptional circumstances, prior to expiry of the original bid validity period, the Employer may request that the Bidders extend the period of validity for a specified additional period which normally may not be more than the original bid validity period. The request and the responses thereto shall be made in writing. A Bidder may refuse the request without forfeiting his Bid Security. A Bidder agreeing to the request will not be required or permitted to modify his bid, but will be required to extend the validity of his Bid Security for the period of the extension, and in compliance with Clause IB.16 in all respects.
- IB.16 Bid Security**
- 16.1 Each Bidder shall furnish, as part of his bid, a Bid Security in original form in the amount stipulated in the **Bidding Data** in PKR or an equivalent amount in a freely convertible currency.



- 16.2 The Bid Security shall be, at the option of the Bidder, in the form of Call Deposit Receipt (CDR) / Pay Order by a Scheduled Bank in Pakistan. The Bid Security of Joint Venture shall be in the name of Joint Venture or Lead partner, submitting the bid.
  - 16.3 Any Bid not accompanied by an acceptable Bid Security shall be rejected by the Employer as non-responsive.
  - 16.4 The Bid Securities of the Bidders except the lowest three will be returned by the Employer within twenty eight (28) days from the opening of Bids, provided a Bidder requests for the return of its Bid Security, or upon the expiry of original validity of Bid Security or as extended, whichever is earlier.
  - 16.5 The Bid Security of the lowest three Bidders including the successful Bidder will be returned when the successful Bidder has furnished the required Performance Security.
  - 16.6 The Bid Security may be forfeited:
    - (a) if the Bidder withdraws his bid except as provided in Sub Clause IB.22.1;
    - (b) if the Bidder does not accept the correction of his Bid Price pursuant to Sub Clause IB.28.2 hereof; or
    - (c) in the case of successful Bidder, fails to furnish the required Performance Security.
  - 16.7 In case of annulment, all Bids submitted and specially, Bid securities, shall be returned to the Bidders within 14 days of annulment.
- IB.17 Alternative Proposals by Bidder**
- 17.1 Unless otherwise specified in the **Bidding Data**, alternative proposal(s) shall not be considered.
  - 17.2 Should any Bidder consider that he can offer any advantages to the Employer by a modification to the designs, specifications or other conditions, he may, in addition to his Bid to be submitted in strict compliance with the Bidding Documents, submit any alternative proposal(s) containing



(a) relevant design calculations; (b) technical specifications; (c) proposed construction methodology; and (d) any other relevant details/conditions, provided always that the total sum entered on the Letter of Bid shall be that which represents complete compliance with the Bidding Documents.

17.3 Alternative proposal(s), if any, of the Bidder having submitted most advantageous Bid only may be considered by the Employer as the basis for the award of Contract to such Bidder.

**IB.18 Format and Signing of Bid**

18.1 Bidders are particularly directed that the amount entered on the Letter of Bid shall be for performing the Contract strictly in accordance with the Bidding Documents.

18.2 All Schedules to Bid are to be properly completed and signed.

18.3 No alteration is to be made in the Letter of Bid nor in the Schedules thereto except in filling up the blanks as directed. If any such alterations be made or if these instructions be not fully complied with, the Bid may be rejected.

18.4 Each Bidder shall prepare by filling in the forms completely and without alterations one (1) original and number of copies, specified in the **Bidding Data**, of the documents comprising the Bid as described in Clause IB.12 and clearly mark them "ORIGINAL" and "COPY" as appropriate. In the event of discrepancy between them, the original shall prevail.

The Bidder shall also provide complete searchable PDF versions as well as Word, Excel\_etc., versions of the Bid if so required in the **Bidding Data**.

18.5 The original of the Bid shall be typed or written in indelible ink and shall be signed by a person or persons duly authorized to sign on behalf of the Bidder pursuant to Sub-Clause IB.12.1(d) hereof. All pages of the Bid shall be initialled and stamped by the person or persons signing the bid.

18.6 The Bid shall contain no alterations, omissions or additions, except to comply with instructions issued by the Employer, or as are necessary to correct errors made by the Bidder, in which case such corrections shall be initialled by the person or persons signing the Bid.

18.7 Bidders shall indicate in the space provided in the Letter of Bid their full and proper addresses at which notices may be legally served on them and to which all correspondence in connection with their bids and the Contract is to be sent.

18.8 Bidders should retain a copy of the Bidding Documents and the Bid as their file copy.

18.9 All documents executed outside Pakistan required to be submitted with the Bid must be certified by Pakistani Embassy in the respective country(ies).



**D. SUBMISSION OF BIDS**

**IB.19 Sealing and Marking of Bids**

19.1 Only through EPADS – PPRA.

**IB.20 Deadline for Submission of Bids**

20.1 (a) Bids must be received by the Employer at the address specified no later than the time and date stipulated in the **Bidding Data**.

(b) Bids with charges payable will not be accepted, nor will arrangements be undertaken to collect the bids from any delivery point other than that specified above. Bidders shall bear all expenses incurred in the preparation and delivery of Bids. No claims will be entertained for refund of such expenses.

(c) Where delivery of a Bid is by mail and the Bidder wishes to receive an acknowledgment of receipt of such Bid, he shall make a request for such acknowledgment in a separate letter attached to but not included in the sealed Bid envelope.

(d) Upon request, acknowledgment of receipt of Bids will be provided to those making delivery in person or by messenger.

20.2 The Employer may, at his discretion, extend the deadline for submission of Bids by issuing an amendment in accordance with Clause IB.9, in which case all rights and obligations of the Employer and the Bidders previously subject to the original deadline will thereafter be subject to the deadline as extended.



**IB.21 Late Bids**

- 21.1 (a) Any Bid received by the Employer after the deadline for submission of bids prescribed in Clause IB.20 shall be declared late, rejected and returned unopened to such Bidder.
- (b) Delays in the mail, delays of person in transit, or delivery of a Bid to the wrong office shall not be accepted as an excuse for failure to deliver a Bid at the proper place and time. It shall be the Bidder's responsibility to determine the manner in which timely delivery of his Bid will be accomplished either in person, by messenger or by mail.

**IB.22 Modification, Substitution and Withdrawal of Bids**

- 22.1 Any Bidder may modify, substitute or withdraw his Bid after Bid submission provided that the modification, substitution or written notice of withdrawal is received by the Employer prior to the deadline for submission of bids.
- 22.2 The modification, substitution, or notice for withdrawal of any Bid shall be prepared, sealed, marked and delivered in accordance with the provisions of Clause IB.19 with the outer and inner envelopes additionally marked "MODIFICATION", "SUBSTITUTION" or "WITHDRAWAL" as appropriate.
- 22.3 No Bid may be modified by a Bidder after the deadline for submission of Bids except in accordance with Sub Clauses IB.22.1 and 28.2.
- 22.4 Withdrawal of a Bid during the interval between the deadline for submission of Bids and the expiration of the period of Bid validity specified in the Letter of Bid may result in forfeiture of the Bid security in pursuance to Clause IB.16.

**E. BID OPENING AND EVALUATION**

**IB.23 Bid Opening**

- 23.1 The Employer will open the Bids including withdrawals, substitution and modifications made pursuant to Clause IB.22, in the presence of Bidders' representatives who choose to attend, at the time, date and location stipulated in the **Bidding Data**. The Bidders' representatives who are present shall sign a register evidencing their attendance.
- 23.2 Envelopes marked "MODIFICATION", "SUBSTITUTION" or "WITHDRAWAL" shall be opened and read out first. Bids for which an acceptable notice of withdrawal has been submitted pursuant to Clause IB.22 shall not be opened. Only bids that are opened and read out at Bid opening shall be considered further.
- 23.3 The Bidder's name, total Bid Price and price of any alternative proposal(s), any discounts, Bid modifications, substitution and withdrawals, the presence or absence of Bid security, and such other details as the Employer may consider appropriate, will be announced by the Employer at the opening of Bids. Only discounts and alternative proposals



read out at Bid opening shall be considered for evaluation. The Letter of Bid and the Summary Bill of Quantities are to be initialled by representative(s) of the Employer attending Bid opening. The Employer shall neither discuss the merits of any Bid nor reject any Bid (except for late Bids, in accordance with Sub-Clause IB 21.1).

23.4 The Employer shall prepare minutes of the Bid opening, including the information disclosed to those present in accordance with the Sub-Clause IB.23.3.

**IB.24 Process to be Confidential**

24.1 Information relating to the examination, clarification, evaluation and comparison of Bids and recommendations for the award of Contract shall not be disclosed to Bidders or any other person not officially concerned with such process before the announcement of the result of Bid evaluation in the form of final evaluation report giving justification for acceptance or rejection of Bids which shall be done at least fifteen (15) days prior to award of Contract. The announcement to all Bidders will include table(s) comprising read out prices, discounted prices, price adjustments made, final evaluated prices and recommendations against all the Bids evaluated. Any effort by a Bidder to influence the Employer's processing of Bids or Contract award decisions may result in the rejection of such Bidder's Bid. Whereas any Bidder feeling aggrieved may lodge a written complaint not later than five (5) days after the announcement of the final evaluation report.

**IB.25 Clarification of Bids**

25.1 To assist in the examination, evaluation and comparison of Bids, the Employer may, at his discretion, ask any Bidder for clarification of his Bid, including breakdowns of unit rates and lump sum prices. Any clarification submitted by a Bidder that is not in response to a request by the Employer shall not be considered. The request for clarification and the response shall be in writing. No change in the price or substance of the Bid shall be sought, offered or permitted except as required to confirm the correction of arithmetic errors discovered by the Employer in the evaluation of the Bids in accordance with Clause IB.28.

25.2 The Employer may, at his discretion, ask any Bidder for confirmation/submission of missing information to clarify its Bid. However, the Employer does not have an obligation to request any additional information or clarification with respect to missing or deficient information in a Bid. The Employer may reject any Bid as non-responsive if found materially incomplete, obscure, irregular or omitting any material information required to be submitted in accordance with the Bidding Documents.

25.3 If a Bidder does not provide clarifications of its Bid by the date and time set reasonably (not less than seven (7) days) in the Employer's request for clarification, the Employer may proceed with the evaluation based on the information submitted in the Bid without waiting for the Bidder's response.



- IB.26 Examination of Bids and Determination of Responsiveness**
- 26.1 Prior to the comparison of Bids, the Employer will determine whether each Bid is substantially responsive to the requirements of the Bidding Documents.
- 26.2 The Employer's determination of a Bid's responsiveness is to be based on the contents of the Bid itself, as defined in Sub-Clause IB.12.
- 26.3 A substantially responsive Bid is one which meets the requirements of the Bidding Documents, without material deviation, reservation or omission. A material deviation, reservation or omission is one that,
- (a) if accepted, would:
    - (i) affect in any substantial way the scope, quality or performance of the Works; or
    - (ii) limit in any substantial way, inconsistent with the Bidding Documents, the Employer's rights or the Bidder's obligations under the proposed Contract; or
  - (b) if rectified, would unfairly affect the competitive position of other Bidders presenting substantially responsive Bids.
- 26.4 During the evaluation of Bids, the following definitions apply:
- (a) "Deviation" is a departure from the requirements specified in the Bidding Documents;
  - (b) "Reservation" is the setting of limiting conditions or withholding from complete acceptance of the requirements specified in the Bidding Documents; and
  - (c) "Omission" is the failure to submit part or all of the information or documentation required in the Bidding Documents.
- 26.5 The Employer shall examine the technical aspects of the Bid submitted in accordance with Sub-Clause IB.12.1(f), in particular, to confirm that all requirements stated in Specifications have been met without any material deviation, reservation or omission.
- 26.6 If a Bid is not substantially responsive to the requirements of the Bidding Documents, it will be rejected by the Employer, and may not subsequently be made responsive by correction or withdrawal of the non-conforming deviation, reservation or omission.
- IB.27 Nonmaterial Nonconformities**
- 27.1 Provided that a Bid is substantially responsive, the Employer may waive any nonconformities in the Bid.
- 27.2 Provided that a Bid is substantially responsive, the Employer may request that the Bidder submit the necessary information or documentation, within a reasonable period of time, to rectify nonmaterial nonconformities in the Bid related to documentation requirements. Requesting information or



documentation on such nonconformities shall not be related to any aspect of the price of the Bid. Failure of the Bidder to comply with the request may result in the rejection of its Bid.

27.3 Provided that a Bid is substantially responsive, the Employer shall rectify quantifiable nonmaterial nonconformities related to the Bid Price. To this effect, the Bid Price shall be adjusted, for comparison purposes only, to reflect the price of a missing or non-conforming item or component, by adding the average price of the item or component quoted by other lowest two evaluated substantially responsive Bidders. If the price of the item or component cannot be derived from the price of other substantially responsive Bids, the Employer shall use a suitable CSR, adjusted to the date 28 days earlier to the Bid submission date or its best assessment.

**IB.28 Correction of Arithmetic Errors**

28.1 Bids determined to be substantially responsive will be checked by the Employer for any arithmetic errors. Errors will be corrected by the Employer as follows:

- (a) where there is a discrepancy between the amounts in figures and in words, the amount in words will govern.
- (b) where there is a discrepancy between the unit rate and the line item total resulting from multiplying the unit rate by the quantity, the unit rate as quoted will govern, unless in the opinion of the Employer there is an obviously gross misplacement of the decimal point in the unit rate, in which case the line item total as quoted will govern and the unit rate will be corrected.
- (c) if there is an error in a total corresponding to the addition or subtraction of subtotals, the subtotals shall prevail and the total shall be corrected.

28.2 The amount stated in the Letter of Bid will be adjusted by the Employer in accordance with the above procedure for the correction of errors and with the concurrence of the Bidder, shall be considered as binding upon the Bidder. If the Bidder does not accept the corrected Bid Price, his Bid will be rejected, and the Bid security shall be forfeited in accordance with Sub Clause IB.16.6(b) hereof.

**IB.29 Evaluation and Comparison of Bids**

29.1 The Employer will evaluate and compare only the Bids determined to be substantially responsive in accordance with Clause IB.26. The Employer shall use the criteria and methodologies listed in this Clause. No other evaluation criteria or methodologies shall be permitted.

29.2 In evaluating and comparing the Bids, the Employer will determine for each Bid the evaluated Bid Price by adjusting the Bid Price as follows:

- (a) making any correction for arithmetic errors pursuant to Clause IB.28;



- (b) price adjustment due to discounts offered in accordance with Sub-Clause IB.23.3;
- (c) excluding Provisional Sums and the provision, if any, for contingencies in the Summary Bill of Quantities, but including competitively priced daywork;
- (d) making an appropriate price adjustment for any quantifiable nonmaterial nonconformities in accordance with Sub-Clause IB.27.3; and
- (e) the additional evaluation factors are specified in Section Evaluation Criteria and Qualification Updating Forms.

29.3 The estimated effect of the price adjustment provisions of the Conditions of Contract, applied over the period of execution of the Contract, shall not be taken into account in Bids' comparison.

**IB.30 Abnormally Low Bids**

30.1 If the Bid Price of the successful Bidder is more than 15% below the lower of the Employer's estimate of the cost of work to be performed under the Contract or average of other lowest two evaluated substantially responsive Bids, the Employer may require the Bidder to produce detailed price analyses for any or all items of the Bill of Quantities to demonstrate the internal consistency of those prices with the construction methods and schedule proposed. After evaluation of the price analyses, the Employer may require an additional Performance Security by 10% of the difference of the Bid Price as determined hereinabove upto issuance of Taking Over Certificate at the expense of the successful Bidder to a level sufficient to protect the Employer against financial loss in the event of default of the successful Bidder under the Contract. The Bids having Bid Price lower than 25% shall be liable to be rejected.

**IB.31 Unbalanced or Front Loaded Bids**

31.1 If the Bid of the successful Bidder is seriously unbalanced (Front Loaded) in relation to the average of other evaluated substantially responsive Bids, the Employer during execution of contract may pay against measured quantities of significantly higher quoted line item(s) rate(s) with respect to same line item(s) rate(s) determined from the average of other lowest two evaluated substantially responsive Bids as instructed by the Engineer. The balance line item(s) rate(s) may be paid against the same measured quantities at the time of issuance of Taking Over Certificate or as instructed by the Engineer.

**F. AWARD OF CONTRACT**

**IB.32 Award Criteria**

32.1 Subject to Clauses IB.33 and IB.39, the Employer will award the Contract to the Bidder whose Bid has been determined as most advantageous Bid (substantially responsive to requirements of the Bidding Documents with the lowest evaluated Bid Price).



- IB.33 Employer’s Right to Annul the Bidding Process**
- 33.1 Notwithstanding Clause IB.32, the Employer reserves the right to annul the bidding process and reject all Bids, at any time prior to award of Contract, without thereby incurring any liability to the affected Bidders or any obligation.
- The Employer shall upon request communicate to any Bidder who submitted a Bid, the grounds for its rejection of all Bids but is not required to justify those grounds. Rejection of all Bids shall be notified to all Bidders promptly.
- IB.34 Notification of Award**
- 34.1 Prior to expiration of the period of Bid validity prescribed by the Employer, the Employer will notify the successful Bidder in writing (“Letter of Acceptance”) that his Bid has been accepted. This letter shall name the sum which the Employer will pay the Contractor in consideration of the execution and completion of the Works by the Contractor as prescribed by the Contract (hereinafter and in the Conditions of Contract called the “Accepted Contract Amount”).
- The Letter of Acceptance will also state the remedies with respect to Sub-Clauses IB.30 & IB.31 if applicable.
- 34.2 No negotiation with the Bidder having submitted most advantageous Bid or any other Bidder shall be permitted, however, Employer may have clarification meetings before issuing Letter of Acceptance to get clarified any item in the Bid evaluation report.
- 34.3 The Letter of Acceptance/ notification of award and its acknowledgement/acceptance by the Bidder will constitute the formation of the Contract, binding the Employer and the Bidder till signing of the formal Contract Agreement.
- 34.4 Upon furnishing by the successful Bidder of a Performance Security, the Employer will promptly notify the other Bidders that their Bids have been unsuccessful and return their Bid securities in accordance with Sub-Clause IB.16.5.
- IB.35 Performance Security**
- 35.1 The successful Bidder shall furnish to the Employer a Performance Security in the form and the amount stipulated in the Conditions of Contract and additional Performance Security if applicable under IB.30 as stated in the Letter of Acceptance, within a period of 28 days after the receipt of Letter of Acceptance.
- 35.2 Failure of the successful Bidder to comply with the requirements of Sub Clause IB.35.1 or Clauses IB.36 or IB.37 shall constitute sufficient grounds for the annulment of the award, forfeiture of the Bid security and to award the Contract to the Bidder having submitted next advantageous Bid.
- IB.36 Signing of Contract Agreement**
- 36.1 Within 14 days from the date of furnishing of acceptable Performance Security under the Conditions of Contract, the Employer will notify the successful Bidder to depute its representative with appropriate Power of Attorney to sign the Contract Agreement in the form provided in the Bidding Documents, incorporating all agreements between the parties.



- 36.2 The formal Agreement between the Employer and the successful Bidder shall be executed within 14 days of the receipt of the above stated notification by the successful Bidder from the Employer.
- IB.37 Integrity Pact** 37.1 The Bidder shall sign and stamp the Integrity Pact provided at Schedule-J to Bid in the Bidding Documents for all Federal Government procurement contracts exceeding PKR ten million. Failure to provide such Integrity Pact shall make the Bidder non-responsive.
- IB.38 Instructions not Part of Contract** 38.1 Bids shall be prepared and submitted in accordance with the Instructions to Bidders which are provided to assist the Bidders in preparing Bids but do not constitute part of the Contract.
- IB.39 Corrupt and Fraudulent Practices** 39.1 The Employer will reject a Bid if it determines that the Bidder recommended for award, or any of its personnel, or its agents, or its sub-contractors, service providers, suppliers and/or their employees, has, directly or indirectly, engaged in corrupt, fraudulent, collusive, coercive, or obstructive practices in competing for the contract under this bidding.
- 39.2 The Employer will blacklist and hence forthwith debar a Constructor or individual, at any time, in accordance with the prevailing Public Procurement Rules 2004.



## **BIDDING DATA (BD)**



### BIDDING DATA

IB Clause Reference	Bidding Data
1.1	Name and address of the Employer: <b>Project Management Office (PMO)</b> <b>National University of Technology (NUTECH)</b> <b>Kamal Sher Khan Shaheed Road, Sector I-12, Islamabad-44000.</b> Telephone : 051-5476768, 5476809 Ext: 234, 219 Email : pm.office@nutech.edu.pk Website : <a href="http://nutech.edu.pk">http://nutech.edu.pk</a>
1.1	Name of the Project & Summary of the Works: <b>Provision of ICT Services at Main Campus, NUTECH</b> <b>Islamabad Through PSDP</b> <b>106/PMO/ICT/01</b>
1.2	Time for Completion for the Works: <b>45 Days (One &amp; a Half Months)</b>
2.1	Name of the Borrower/Source of Funding: <b>PSDP Funded project</b>
8.1	Time limit for clarification: <b>7 Days</b>
8.3	Venue, time, and date of the pre-Bid meeting: <b>Project Management Office (PMO)</b> <b>National University of Technology (NUTECH)</b> <b>Kamal Sher Khan Shaheed Road, Sector I-12, Islamabad-44000.</b> <b>On 22<sup>nd</sup> April 2026 at 1100 hrs.</b>
11.1	Bid language: <b>English</b>



IB Clause Reference	Bidding Data
12.2	Maximum number of JV Partners shall be <b>Two (02)</b> and lead partner should be an Authorized manufacturer / Authorized Distributor.
14.1	Bidders to quote entirely in Pak. Rs
15.1	Period of Bid Validity: <b>90 Days</b>
16.1	Amount of Bid Security: <b>2,000,000/- (Two Million)</b>
17.1	Alternative Proposal(s) by the Bidder <b><u>Shall not be</u></b> considered.
18.4	Bids only be submitted online through EPADS – PPRA
19.2(a)	Employer's address for the purpose of Bid submission: <b>Director PMO National University of Technology (NUTECH) Kamal Sher Khan Shaheed Road, Sector I-12, Islamabad-44000.</b>
19.2(b)	Name and Number of the Contract: <b>Provision of ICT Services at Main Campus, NUTECH Islamabad Through PSDP 106/PMO/ICT/01</b>
20.1(a)	Deadline for submission of Bids: Day : <b>Monday</b> Date: <b>4<sup>th</sup> May, 2026</b> Time: <b>1100 hrs</b>
23.1	Venue, time, and date of Bid opening: <b>Main Conference Room (MCR), Level 4, Administration Block National University of Technology (NUTECH) Kamal Sher Khan Shaheed Road, Sector I-12, Islamabad-44000</b> Day : <b>Monday</b> Date: <b>4<sup>th</sup> May, 2026</b> Time: <b>1145 hrs</b>



*Provision of ICT Services – (Academic Block)*

# **SECTION – VI EVALUATION CRITERIA AND QUALIFICATION UPDATING FORMS**



## **EVALUATION CRITERIA AND QUALIFICATION UPDATING FORMS**

### **1. General**

This Section contains Eligibility and Qualification Criteria that the Employer shall use to evaluate Bids and qualify Bidders in accordance with Clauses IB.3 of Instructions to Bidders. The Bidder shall provide all the information requested in the relevant forms contained in Bidder's Qualification Updating Forms provided herein.

The information provided in the forms shall be substantiated with valid documentary evidences otherwise the requirement will not be considered as complied. Non-compliance with any form of bidding document will result in the rejection of respective bid.

### **2. Evaluation**

Quality cum Cost based selection method be used for bids evaluation. The weights given to the Technical and Financial bids are as follow: -

T = the weight given to the Technical Proposal = 80%

P = the weight given to the Financial Proposal = 20%

The markings for & formula used for technical & financial bids evaluation is provided on next pages and same for all three Lots;



### Qualification.

Eligibility and Qualification Criteria		Compliance Requirements					Documentation
No.	Subject	Requirement	Single Entity	Joint Venture (existing or intended)			Submission Requirements
				All Combined	Parties Each Member	One Member	
<b>1. Eligibility</b>							
1.1	<b>Nationality</b>	Nationality in accordance with <b>ITB 4.3</b>	Must meet requirement	Must meet requirement	Must meet requirement	N/A	Forms ELI – 1.1 and 1.2, with attachments
1.2	<b>Conflict of Interest</b>	No conflicts of interest in accordance with <b>ITB 3.7</b>	Must meet requirement	Must meet requirement	Must meet requirement	N/A	Letter of Bid
1.3	<b>Active Tax Payer</b>	Registration with FBR in “Income Tax” as well as in “Sales Tax” in accordance with Bidding Data Sheet (BDS)	Must meet requirement	N/A	Must meet requirement	Must meet requirement	Valid FBR Registration for the year 2025 with documentary evidence
1.4	<b>Debarment/ Blacklisting</b>	Undertaking at Stamp Paper of Rs. 100/- with attested by Notary Public for not having been debarment/ blacklisted	Must meet requirement	Must meet requirement	Must meet requirement	Must meet requirement	List of any past or present satisfactory performance of the bidder as contractor (individual or all partners of a JV) from any other executing agency and the contractor has not been blacklisted earlier by any Procuring Agency, Government or Semi Government Departments, Autonomous Bodies, International Organization and any Client/ Employer or Cantonments in Pakistan.
1.5	<b>OEM Authorization</b>	Authorization certificates from principal OEMs	Must meet requirement	Must meet requirement	N/A	Must meet requirement	Documentary Proof OEM Authorization



Eligibility and Qualification Criteria			Compliance Requirements				Documentation
No.	Subject	Requirement	Single Entity	Joint Venture (existing or intended)			Submission Requirements
				All Parties Combined	Each Member	One Member	
<b>2. Historical Contract Non-Performance</b>							
2.1	<b>History of Non-Performing Contracts</b>	Non-performance of a contract did not occur as a result of contractor default for last (03) years	Must meet requirement	Must meet requirements	Must meet requirement	N/A	Form CON-2
2.2	<b>Pending Litigation</b>	Bidder's financial position and prospective long term profitability sound according to criteria established in 3.1 below and assuming that all pending litigation will be resolved against the Bidder	Must meet requirement	N/A	Must meet requirement	N/A	Form CON – 2
2.3	<b>Litigation History</b>	No consistent history of court/arbitral award decisions against the Bidder since 1 <sup>st</sup> January Jan 2021	Must meet requirement	Must meet requirement	Must meet requirement	N/A	Form CON – 2



Eligibility and Qualification Criteria			Compliance Requirements			Documentation	
No.	Subject	Requirement	Single Entity	Joint Venture (existing or intended)			Submission Requirements
				All Parties Combined	Each Member	One Member	
<b>3. Financial Situation and Performance</b>							
3.1	<b>Financial Capabilities</b>	<p>(i) The Bidder shall demonstrate that it has access to, or has available, liquid assets, unencumbered real assets, lines of credit, and other financial means (independent of any contractual advance payment) sufficient to meet the cash flow requirements for the subject contract(s) net of the Bidders other commitments</p> <p>(ii) The Bidders shall also demonstrate, to the satisfaction of the Procuring agency/Employer, that it has adequate sources of finance to meet the cash flow requirements on works currently in progress and for future contract commitments.</p> <p>(iii) The audited balance sheets or, if not required by the laws of the Bidder's country, other financial statements acceptable to the Procuring agency/Employer for the last <b>03 (three) years</b> shall be submitted and must demonstrate the current soundness of the Bidder's financial position and indicate its prospective long-term profitability.</p>	Must meet requirement	N/A	N/A	Must meet requirement	Form FIN – 3.1, with attachments
3.2	<b>Average Annual Turnover</b>	Minimum average annual turnover of <b>Rs. 250 Million</b> calculated as total certified payments received for contracts in progress and/or completed within the last <b>03 (three) years</b> .	Must meet requirement	N/A	N/A	Must meet requirement	Form FIN – 3.2



Eligibility and Qualification Criteria		Compliance Requirements			Documentation		
No.	Subject	Requirement	Single Entity	Joint Venture (existing or intended)			Submission Requirements
				All Parties Combined	Each Member	One Member	
<b>4. Experience</b>							
4.1	<b>Experience</b>	Firm that has completed projects i.e. <b>“Provision of ICT works”</b> of similar size and complexity in public sector institutions as a prime contractor during <b>last Five (05) years. (Minimum 3 Projects)</b> . In case of JV, if lead partner alone fulfils the condition, then the other partner is not required to fulfil the condition, otherwise each member shall be assessed according to its share in JV. <ul style="list-style-type: none"> <li>• Projects should be related to building works of govt. institutions (schools / colleges / universities)</li> </ul>	must meet requirement	Must meet requirement as follows: Either one partner must meet requirement; or Any two partners must each demonstrated successfully completed contracts of relevant and similar size	N/A	must meet requirement	Form EXP - 4.2  Documentary proof (i.e. purchase order / work order / completion certificate, Manufacturer Authorization Certificate, duly attested via email) be attached.  Documentary proof should be strictly clearly readable, otherwise the project will not be considered for evaluation.



*Provision of ICT Services – (Academic Block)*

Eligibility and Qualification Criteria			Compliance Requirements				Documentation
No.	Subject	Requirement	Single Entity	Joint Venture (existing or intended)			Submission Requirements
				All Parties Combined	Each Member	One Member	
<b>5. Personnel</b>							
5.1	<b>Contractors Representative and Key Personnel</b>	Qualified / Certified Engineers & Technicians	must meet requirement	N/A	N/A	must meet requirement	Form PER 1 & 2



## Technical Evaluation Criteria

Ser No.	Description	Marks
<b>Eligibility</b>		<b>10</b>
1.	FBR Active Tax Payer	2.5
2.	No Blacklisting (Affidavit on stamp paper of Rs. 100)	2.5
3.	OEM Authorization (Evidence Letter Should be attached with bid)	5
<b>Experience</b>		<b>15</b>
4.	<u>Experience</u> Firm that has completed projects i.e. “Provision of ICT Services” of similar size and complexity in public sector institutions as a prime contractor of Rs. 50 Million each project cost or more during last Five (05) years. (Minimum 5 Projects). <i>Note: Each project = 3 marks</i>	15
<b>Technical Staff</b>		<b>15</b>
5.	<u>Qualified / Certified Engineers &amp; Technicians</u> (Minimum 5 Engineers / Technicians) <i>Note: Each Engineer = 3 marks</i>	15
<b>Financial Capacity</b>		<b>20</b>
6.	Audit Report of Last 3 years (2023 - 2025)	5
7.	Having 250 Million average annual turnover <i>Note: If avg annual turnover is;</i> <ul style="list-style-type: none"><li>• &lt; 100 Mn = 3 Marks</li><li>• 100 - 200 Mn = 6 Marks</li><li>• 201 - 250 Mn = 12 Marks</li></ul>	15
<b>Technical Compliance</b>		<b>10</b>
8.	Organizational Chart	3
9.	Work Schedule, manpower deployment	4
10.	Compliance with Bidding Documents	3
<b>TOTAL</b>		<b>70</b>
<b>Bonus Points</b>		<b>7.5</b>
11.	Registered in Pakistan Engineering Council (PEC) in Category C-3 or Above.	2.5
12.	Samples Provided with Bids of items mentioned in BqoQs	2.5
13.	Credit line facility	2.5

*Note: Bidders scoring less than 70% in Technical Evaluation will be disqualified and their financial bids will remain unopened.*



## Financial Evaluation Criteria

The evaluation committee shall determine whether the financial bids are complete and without computational errors. The lowest financial bid (Fm) among all shall be given a financial score (Sf) of 100 points. The financial scores of the bids shall be computed as follows:

$$Sf=100 \times Fm/F$$

(F = amount of specific financial proposal)

## Final Evaluation

Bids, in the quality cum cost-based selection shall finally be ranked according to their combined technical (St) and financial (Sf) scores using the weights (T = the weight given to the technical proposal, P = the weight given to the financial proposal; and T+P=1) indicated in the Data Sheet:

$$S = St \times T \% + Sf \times P\%$$

The Bidder having the highest score will be considered as the, **“MOST ADVANTAGEOUS BIDDER”**.



# FORM ELI 1

## Bidder Information Form

*[The Bidder shall fill in this Form in accordance with the instructions indicated below. No alterations to its format shall be permitted and no substitutions shall be accepted.]*

Date: \_\_\_\_\_

Tender Ref No.: 106/PMO/ICT/01

Alternative No.: \_\_\_\_\_

Page \_\_\_\_\_ of \_\_\_\_\_ pages

1. Bidder's Name <i>[insert Bidder's legal name]</i>
2. In case of JV, legal name of each member : <i>[insert legal name of each member in JV]</i>
3. Bidder's actual or intended country of registration: <i>[insert actual or intended country of registration]</i>
4. Bidder's year of registration: <i>[insert Bidder's year of registration]</i>
5. Bidder's Address in country of registration: <i>[insert Bidder's legal address in country of registration]</i>
6. Bidder's Authorized Representative Information Name: <i>[insert Authorized Representative's name]</i> Address: <i>[insert Authorized Representative's Address]</i> Telephone/Fax numbers: <i>[insert Authorized Representative's telephone/fax numbers]</i> Email Address: <i>[insert Authorized Representative's email address]</i>
7. Attached are copies of original documents of <i>[check the box(es) of the attached original documents]</i> <input type="checkbox"/> Articles of Incorporation (or equivalent documents of constitution or association), and/or documents of registration of the legal entity named above. <input type="checkbox"/> In case of JV, JV agreement attached <input type="checkbox"/> Establishing that the Bidder is not under the supervision of the Procuring agency/Employer[ in case of subsidiaries]
8. Included are the organizational chart, a list of Board of Directors, and the beneficial ownership.



## ELI2

### Bidder's JV Members Information Form

[The Bidder shall fill in this Form in accordance with the instructions indicated below. The following table shall be filled in for the Bidder and for each member of a Joint Venture].

Date: \_\_\_\_\_

Tender Ref No.: 106/PMO/IT/01

Alternative No.: \_\_\_\_\_

Page \_\_\_\_\_ of \_\_\_\_\_ pages

1. Bidder's Name: <i>[insert Bidder's legal name]</i>
2. Bidder's JV Member's name: <i>[insert JV's Member legal name]</i>
3. Bidder's JV Member's country of registration: <i>[insert JV's Member country of registration]</i>
4. Bidder's JV Member's year of registration: <i>[insert JV's Member year of registration]</i>
5. Bidder's JV Member's legal address in country of registration: <i>[insert JV's Member legal address in country of registration]</i>
6. Bidder's JV Member's authorized representative information Name: <i>[insert name of JV's Member authorized representative]</i> Address: <i>[insert address of JV's Member authorized representative]</i> Telephone/Fax numbers: <i>[insert telephone/fax numbers of JV's Member authorized representative]</i> Email Address: <i>[insert email address of JV's Member authorized representative]</i>
7. Attached are copies of original documents of <i>[check the box(es) of the attached original documents]</i> <input type="checkbox"/> Articles of Incorporation (or equivalent documents of constitution or association), and/or registration documents of the legal entity named above.
8. Included are the organizational chart, a list of Board of Directors, and the beneficial ownership.



## Personnel

### Form PER -1

## Contractor's Representative and Key Personnel Schedule

Bidders should provide the names and details of the suitably qualified Contractor's Representative and Key Personnel to perform the Contract. The data on their experience should be supplied using the Form PER-2 below for each candidate.

### Contractor' Representative and Key Personnel

1.	<b>Title of position:</b>	
	<b>Name of candidate:</b>	
	<b>Duration of appointment:</b>	<i>[insert the whole period (start and end dates) for which this position will be engaged]</i>
	<b>Time commitment for this position:</b>	<i>[insert the number of days/week/months/ that has been scheduled for this position]</i>
	<b>Expected time schedule for this position:</b>	<i>[insert the expected time schedule for this position (e.g. attach high level Gantt chart]</i>
2.	<b>Title of position:</b>	
	<b>Name of candidate:</b>	
	<b>Duration of appointment:</b>	<i>[insert the whole period (start and end dates) for which this position will be engaged]</i>
	<b>Time commitment for this position:</b>	<i>[insert the number of days/week/months/ that has been scheduled for this position]</i>
	<b>Expected time schedule for this position:</b>	<i>[insert the expected time schedule for this position (e.g. attach high level Gantt chart]</i>
3.	<b>Title of position:</b>	
	<b>Name of candidate:</b>	
	<b>Duration of appointment:</b>	<i>[insert the whole period (start and end dates) for which this position will be engaged]</i>
	<b>Time commitment for this position:</b>	<i>[insert the number of days/week/months/ that has been scheduled for this position]</i>
	<b>Expected time schedule for this position:</b>	<i>[insert the expected time schedule for this position (e.g. attach high level Gantt chart]</i>



4.	<b>Title of position:</b>	
	<b>Name of candidate:</b>	
	<b>Duration of appointment:</b>	<i>[insert the whole period (start and end dates) for which this position will be engaged]</i>
	<b>Time commitment for this position:</b>	<i>[insert the number of days/week/months/ that has been scheduled for this position]</i>
	<b>Expected time schedule for this position:</b>	<i>[insert the expected time schedule for this position (e.g. attach high level Gantt chart)]</i>
5.	<b>Title of position:</b>	
	<b>Name of candidate</b>	
	<b>Duration of appointment:</b>	<i>[insert the whole period (start and end dates) for which this position will be engaged]</i>
	<b>Time commitment for this position:</b>	<i>[insert the number of days/week/months/ that has been scheduled for this position]</i>
	<b>Expected time schedule for this position:</b>	<i>[insert the expected time schedule for this position (e.g. attach high level Gantt chart)]</i>
6.	<b>Title of position:</b> <i>[insert title]</i>	
	<b>Name of candidate</b>	
	<b>Duration of appointment:</b>	<i>[insert the whole period (start and end dates) for which this position will be engaged]</i>
	<b>Time commitment for this position:</b>	<i>[insert the number of days/week/months/ that has been scheduled for this position]</i>
	<b>Expected time schedule for this position:</b>	<i>[insert the expected time schedule for this position (e.g. attach high level Gantt chart)]</i>

*Note: Extras rows may also attached for additional entries..*



**Form PER-2:  
Resume and Declaration  
Bidder's Representative and Key Personnel**

Page \_\_\_\_\_ of \_\_\_\_\_ pages

<b>Name of Bidder</b>
-----------------------

<b>Position [#1]: [title of position from Form PER-1]</b>
-----------------------------------------------------------

<b>Personnel information</b>	<b>Name:</b>	<b>Date of birth:</b>
	<b>Address:</b>	<b>E-mail:</b>
	<b>Professional qualifications:</b>	
	<b>Academic qualifications:</b>	
	<b>Language proficiency:[language and levels of speaking, reading and writing skills]</b>	
<b>details</b>		
	<b>Address of Procuring agency/Employer:</b>	
	<b>Telephone:</b>	<b>Contact (manager / personnel officer):</b>
	<b>Fax:</b>	
	<b>Job title:</b>	<b>Overall Experience of Personnel:</b>

Summarize professional experience in reverse chronological order. Indicate particular technical and managerial experience relevant to the project.

Project	Role	Duration of involvement	Relevant experience
<i>[main project details]</i>	<i>[role and responsibilities on the project]</i>	<i>[time in role]</i>	<i>[describe the experience relevant to this position]</i>



## Declaration

I, the undersigned [ *insert either “Contractor’s Representative” or “Key Personnel” as applicable* ], certify that to the best of my knowledge and belief, the information contained in this Form PER-2 correctly describes myself, my qualifications and my experience.

I confirm that I am available as certified in the following table and throughout the expected time schedule for this position as provided in the Bid:

<b>Commitment</b>	<b>Details</b>
<b>Commitment to duration of contract:</b>	[ <i>insert period (start and end dates) for which this Contractor’s Representative or Key Personnel is available to work on this contract</i> ]
<b>Time commitment:</b>	[ <i>insert period (start and end dates) for which this Contractor’s Representative or Key Personnel is available to work on this contract</i> ]

I understand that any misrepresentation or omission in this Form may:

- (a) be taken into consideration during Bid evaluation;
- (b) result in my disqualification from participating in the Bid;
- (c) result in my dismissal from the contract.

**Name of Key Personnel:** [*insert name*]

Signature: \_\_\_\_\_

Date: (day month year): \_\_\_\_\_

**Countersignature of authorized representative of the Bidder:**

Signature: \_\_\_\_\_

Date: (day month year): \_\_\_\_\_



## Form CON – 2

### Historical Contract Non-Performance, Pending Litigation and Litigation History

Bidder's Name: \_\_\_\_\_

Date: \_\_\_\_\_

JV Member Name \_\_\_\_\_

Page \_\_\_\_\_ of \_\_\_\_\_ pages

Non-Performed Contracts in accordance with Qualification Criteria			
<input type="checkbox"/> Contract non-performance did not occur January <i>[insert year]</i>			
<input type="checkbox"/> Contract(s) not performed since <i>[insert year]</i>			
Year	Non-performed portion of contract	Contract Identification	Total Contract Amount (current value, currency, exchange rate and PKR equivalent)
		Contract Identification: Name of Procuring agency/Employer(PA): Address of PA: Reason(s) for nonperformance:	
Pending Litigation, in accordance with Qualification Criteria			
<input type="checkbox"/> No pending litigation			
<input type="checkbox"/> Pending litigation			



Year of dispute	Amount in dispute (currency)	Contract Identification	Total Contract Amount
		Contract Identification: _____ Name of PA: _____ Address of PA: _____ Matter in dispute: _____ Party who initiated the dispute: _____  Status of dispute: _____	
Litigation History in accordance with Section III, Evaluation and Qualification Criteria of the Prequalification document			
<input type="checkbox"/> No Litigation History <input type="checkbox"/> Litigation History			
Year of award	Outcome as percentage of Net Worth	Contract Identification	Total Contract Amount (currency), PKR Equivalent (exchange rate)
<i>[insert year]</i>	<i>[insert percentage]</i>	Contract Identification: <i>[indicate complete contract name, number, and any other identification]</i> Name of PA: <i>[insert full name]</i> Address of PA: <i>[insert street/city/country]</i> Matter in dispute: <i>[indicate main issues in dispute]</i> Party who initiated the dispute: <i>[indicate "Procuring agency/Employer" or "Contractor"]</i> Reason(s) for Litigation and award decision <i>[indicate main reason(s)]</i>	<i>[insert amount]</i>



# Financial Situation

## Form FIN – 3.1:

### Financial Situation and Performance

Bidder's Name: \_\_\_\_\_

Date: \_\_\_\_\_

JV Member's Name \_\_\_\_\_

Page \_\_\_\_\_ of \_\_\_\_\_ pages

#### 1. Financial data

Type of Financial information in (currency)	Historic information for previous <i>Three (03) years</i> , (amount in currency, currency, exchange rate*, PKR equivalent)				
	2024	2023	2022	2021	2020
Statement of Financial Position (Information from Balance Sheet)					
Total Assets (TA)					
Total Liabilities (TL)					
Total Equity/Net Worth (NW)					
Current Assets (CA)					
Current Liabilities (CL)					
Working Capital (WC)					
Information from Income Statement					
Total Revenue (TR)					
Profits Before Taxes (PBT)					
Cash Flow Information					
Cash Flow from Operating Activities					



## 2. Sources of Finance

Specify sources of finance to meet the cash flow requirements on works currently in progress and for future contract commitments.

No.	Source of finance	Amount (PKR)
1		
2		
3		

## 2. Financial documents

The Bidder and its parties shall provide copies of financial statements for \_\_\_\_\_ years pursuant to Evaluation and Qualifications Criteria, Sub-factor 3.1. The financial statements shall:

- (a) reflect the financial situation of the Bidder or in case of JV member, and not an affiliated entity (such as parent company or group member).
  - (b) be independently audited or certified in accordance with local legislation.
  - (c) be complete, including all notes to the financial statements.
  - (d) correspond to accounting periods already completed and audited.
- Attached are copies of financial statements for the **Three (03)** years required above; and complying with the requirements



**Form FIN – 3.2:**

**Average Annual Construction Turnover**

Bidder's Name: \_\_\_\_\_

Date: \_\_\_\_\_

JV Member's Name \_\_\_\_\_

Page \_\_\_\_\_ of \_\_\_\_\_ pages

Annual turnover data (construction only)			
Year	Amount Currency	Exchange rate	PKR equivalent
<i>[indicate year]</i>	<i>[insert amount and indicate currency]</i>		
Average Annual Turnover *			

\* See Section IV, Evaluation and Qualification Criteria.



### Form FIN – 3.3:

#### Current Contract Commitments / Works in Progress

Bidders and each member to a JV should provide information on their current commitments on all contracts that have been awarded, or for which a letter of intent or acceptance has been received, or for contracts approaching completion, but for which an unqualified, full completion certificate has yet to be issued.

Current Contract Commitments					
No.	Name of Contract	Procuring agency/Employer's Contact Address, Tel, Fax	Value of Outstanding Work [PKR Equivalent]	Estimated Completion Date	Total Cost (PKR)
1					
2					
3					
4					
5					



**EXPERIENCE**  
**Form EXP - 4.1**  
**Experience**

Bidder's Name: \_\_\_\_\_

Date: \_\_\_\_\_

JV Member's Name \_\_\_\_\_

Page \_\_\_\_\_ of \_\_\_\_\_ pages

Starting Year	Ending Year	Contract Identification	Role of Bidder
		Contract name: _____ Brief Description of the Works performed by the Bidder: _____ Amount of contract: _____ Name of PA: _____ Address: _____	
		Contract name: _____ Brief Description of the Works performed by the Bidder: _____ Amount of contract: _____ Name of PA: _____ Address: _____	
		Contract name: _____ Brief Description of the Works performed by the Bidder: _____ Amount of contract: _____ Name of PA: _____ Address: _____	
		Contract name: _____ Brief Description of the Works performed by the Bidder: _____ Amount of contract: _____ Name of PA: _____ Address: _____	
		Contract name: _____ Brief Description of the Works performed by the Bidder: _____ Amount of contract: _____ Name of PA: _____ Address: _____	

*Note:- A firm may add additional rows to provide further details of the work completed*



## Form EXP - 4.2

### Experience

Bidder's Name: \_\_\_\_\_

Date: \_\_\_\_\_

JV Member's Name \_\_\_\_\_

Page \_\_\_\_\_ of \_\_\_\_\_ pages

Similar Contract No.	Information			
Contract Identification				
Award date				
Completion date				
Role in Contract	Prime Contractor <input type="checkbox"/>	Member in JV <input type="checkbox"/>	Management Contractor <input type="checkbox"/>	Sub-contractor <input type="checkbox"/>
Total Contract Amount			PKR equivalent	
If member in a JV or sub-contractor, specify participation in total Contract amount				
PA's Name:				
Address:				
Telephone/fax number				
E-mail:				



**LETTER OF BID  
AND  
SCHEDULES TO BID**



## LETTER OF BID

**Note:** Letter of Bid will be provided separately for all three lots by vendor.

Bid Reference No. 106/PMO/ICT/01

To: **Director**  
**Project Management Office**  
**NUTECH, Islamabad**

Gentleman,

1. Having examined the Bidding Documents including Instructions to Bidders, Bidding Data, Conditions of Contract, Specifications, Schedules to Bid including Bill of Quantities, Drawings and Addenda for the execution of the above-named Works, we, the undersigned, offer to execute and complete such Works and remedy any defects therein in conformity with the said Bidding Documents and Addenda for the sum of Equivalent PKR \_\_\_\_\_ (Eq. Pak Rupees \_\_\_\_\_) or such other sum as may be ascertained in accordance with the said conditions.
2. We meet the eligibility requirements in accordance with IB.3.
3. We, including any Subcontractors for any part of the Contract, are not debarred/ blacklisted by the Employer, any Government/Semi Government/Public Department in Pakistan or foreign country, international organizations or other foreign institutions.
4. Our subcontractors or suppliers for any part of the Contract, if any, shall have nationalities from eligible countries, in accordance with IB.4.4.
5. We understand that all the Schedules attached hereto form part of this Bid.
6. As security for due performance of the undertakings and obligations of this Bid, we submit herewith a Bid Security in the amount of PKR \_\_\_\_\_ (Pak. Rupees. \_\_\_\_\_) drawn in your favour or made payable to you and valid for a period of \_\_\_\_\_ days beginning from the date Bids are opened.
7. We undertake, if our Bid is accepted, to commence the Works and to complete the whole of the Works comprised in the Contract within the time stated in Contract Data.
8. We agree to abide by this Bid for the period of \_\_\_\_\_ days, inclusive of 14 days beyond Bid validity period (as mentioned at Sr. No. 6 above) and it shall remain binding upon us and may be accepted at any time before the expiration of that period.
9. Unless and until a formal Agreement is prepared and executed, this Bid, together with your written acceptance thereof, shall constitute a binding contract between us.
10. We do hereby declare that the Bid is made without any collusion, comparison of figures or arrangement with any other Bidder for the Works.
11. We understand that you are not bound to accept the lowest or any Bid you may receive.
12. We undertake that all the information and documents submitted with the Bid are genuine, and in case of incorrect information of fake documents we shall be liable for punitive action under the Applicable Law.



Dated this \_\_\_\_\_ day of \_\_\_\_\_ 20 \_\_\_\_\_

Signature: \_\_\_\_\_

in the capacity of \_\_\_\_\_ duly authorized to sign Bids for and on behalf of

\_\_\_\_\_  
*(Name of Bidder in Block Capitals)*  
*(Seal)*

Address: \_\_\_\_\_  
\_\_\_\_\_  
\_\_\_\_\_

Witness:

Signature: \_\_\_\_\_

Name: \_\_\_\_\_

Address. \_\_\_\_\_

Occupation \_\_\_\_\_



## SCHEDULE OF ADJUSTMENT DATA

### Schedule of Cost Indexation

[The Employer is to engage a professional with experience in construction costs and the inflationary effect on construction costs when preparing the contents of the Schedule of Cost Indexation. In the case of very large and/or complex works contracts, it may be necessary to specify several families of price adjustment formulae corresponding to the different works involved.]

[The formulae for price adjustment shall be of the following general type:]

$$P_n = a + b \frac{L_n}{L_0} + c \frac{E_n}{E_0} + d \frac{M_n}{M_0} + \dots$$

where:

“P<sub>n</sub>” is the adjustment multiplier to be applied to the estimated Contract value in the relevant currency of the work carried out in period “n”, this period being a month;

“a” is a fixed coefficient, stated in the relevant table of adjustment data, representing the non-adjustable portion in contractual payments;

“b”, “c”, “d”, ... are coefficients representing the estimated proportion of each cost element related to the execution of the Works as stated in the relevant table of adjustment data; such tabulated cost elements may be indicative of resources such as labour, equipment and materials;

“L<sub>n</sub>”, “E<sub>n</sub>”, “M<sub>n</sub>”, ... are the current cost indices or reference prices for period “n”, expressed in the relevant currency of payment, each of which is applicable to the relevant tabulated cost element on the date 49 days prior to the last day of the period (to which the particular Payment Certificate relates); and

“L<sub>0</sub>”, “E<sub>0</sub>”, “M<sub>0</sub>”, ... are the base cost indices or reference prices, expressed in the relevant currency of payment, each of which is applicable to the relevant tabulated cost element on the Base Date.

The weightings (coefficients) for each of the factors of cost stated in the following table(s) of adjustment data shall only be adjusted if they have been rendered unreasonable, unbalanced or inapplicable, as a result of Variation(s).

If the currency in which the Contract price is expressed is different from the currency of the country of origin of the indices, a correction factor will be applied to avoid incorrect adjustments of the Contract price. The correction factor shall be:  $Z_0 / Z_1$ , where,

$Z_0$  = the number of units of currency of the origin of the indices which equal to one unit of the currency of the Contract Price on the Base date, and

$Z_1$  = the number of units of currency of the origin of the indices which equal to one unit of the currency of the Contract Price on the Date of Adjustment.



# **BILL OF QUANTITIES**

*Ref to the Last pages*



### WORK SCHEDULE

Pursuant to Sub-Clause 8.3 of the General Conditions, the whole of the Works, shall be completed within the Time for Completion for the Works or Section (as the case may be) stated as hereunder and mentioned in Contract Data:

Description	Time for Completion (days)
There are three Lots for subject services at academic block of main campus of National University of Technology, Islamabad. <ul style="list-style-type: none"><li>Lot 1: Passive LAN equipment</li><li>Lot 2: Network Switches, CCTV, &amp; UPS System</li><li>Lot 3: Fire Alarm System</li></ul>	45 calendar days is the duration of execution and will be calculated from the Letter of Commencement.

*[The Bidder shall provide, the Construction Schedule in the bar chart (CPM, PERT or any other to be specified herein) showing the sequence of work items and the period of time during which he proposes to complete each work item in such a manner that his proposed programme for completion of the whole of the Works and Sections of the Works may meet Employer's completion targets in days noted above and counted from the Commencement Date (Attach sheets as required for the specified form of Construction Schedule)]*



## METHOD OF PERFORMING THE WORK

*[The Bidder is required to submit a narrative outlining the method of performing the Work. The narrative should indicate in detail and include but not be limited to:*

1. **Organization Chart:**

*Shall indicate head office and field office personnel involved in management and supervision, engineering, equipment maintenance and purchasing.*

2. **Mobilization:**

*In Pakistan, the type of facilities including personnel accommodation, office accommodation, provision for maintenance and for storage, communications, security and other services to be used.*

3. **Method of performing the Works:**

*The procedures for installation of equipment and machinery and transportation of equipment and materials to the site.]*



**ORGANIZATION CHART**



**LIST OF SUBCONTRACTORS**

I/ We intend to subcontract the following parts of the Work to subcontractors. In my/ our opinion, the subcontractors named hereunder are reliable and competent to perform that part of the work for which each is listed.

Enclosed are documentation outlining experience of subcontractors, the curriculum vitae and experience of their key personnel who will be assigned to the Contract, equipment to be supplied by them, size, location and type of contracts carried out in the past.

<b>Part of Works (Give Details)</b>	<b>Subcontractor (With Complete Address)</b>
1	2



**INTEGRITY PACT**

**DECLARATION OF FEES, COMMISSION AND BROKERAGE, ETC.  
PAYABLE BY THE BIDDERS/CONTRACTORS OF GOODS, SERVICES & WORKS IN  
CONTRACTS WORTH PAK. RS. 10.00 MILLION OR MORE**

Contract No. \_\_\_\_\_ Dated \_\_\_\_\_  
Contract Value: \_\_\_\_\_  
Contract Title: \_\_\_\_\_

..... [Name of Bidder/Contractor] hereby declares that it has not obtained or induced the procurement of any contract, right, interest, privilege or other obligation or benefit from Government of Pakistan (GoP) or any administrative subdivision or agency thereof or any other entity owned or controlled by GoP through any corrupt business practice.

Without limiting the generality of the foregoing, [Name of Bidder/ Contractor] represents and warrants that it has fully declared the brokerage, commission, fees etc. paid or payable to anyone and not given or agreed to give and shall not give or agree to give to anyone within or outside Pakistan either directly or indirectly through any natural or juridical person, including its affiliate, agent, associate, broker, consultant, director, promoter, shareholder, sponsor or subsidiary, any commission, gratification, bribe, finder’s fee or kickback, whether described as consultation fee or otherwise, with the object of obtaining or inducing the procurement of a contract, right, interest, privilege or other obligation or benefit in whatsoever form from GoP, except that which has been expressly declared pursuant hereto.

[Name of Bidder/Contractor] certifies that it has made and will make full disclosure of all agreements and arrangements with all persons in respect of or related to the transaction with GoP and has not taken any action or will not take any action to circumvent the above declaration, representation or warranty.

[Name of Bidder/Contractor] accepts full responsibility and strict liability for making any false declaration, not making full disclosure, misrepresenting facts or taking any action likely to defeat the purpose of this declaration, representation and warranty. It agrees that any contract, right, interest, privilege or other obligation or benefit obtained or procured as aforesaid shall, without prejudice to any other rights and remedies available to GoP under any law, contract or other instrument, be voidable at the option of GoP.

Notwithstanding any rights and remedies exercised by GoP in this regard, [name of Bidder/Contractor] agrees to indemnify GoP for any loss or damage incurred by it on account of its corrupt business practices and further pay compensation to GoP in an amount equivalent to ten time the sum of any commission, gratification, bribe, finder’s fee or kickback given by [name of Bidder/Contractor] as aforesaid for the purpose of obtaining or inducing the procurement of any contract, right, interest, privilege or other obligation or benefit in whatsoever form from GoP.

Name of Employer: .....  
Signature: .....  
[Seal]

Name of Bidder/Contractor: .....  
Signature: .....  
[Seal]



# **STANDARD FORMS**



BS-1

**FORM OF BID SECURITY**

Security Executed on \_\_\_\_\_  
(Date)

Expiry on \_\_\_\_\_  
(Date)

Name of Surety with Address: \_\_\_\_\_  
\_\_\_\_\_

Name of Principal (Bidder) with Address \_\_\_\_\_  
\_\_\_\_\_

Penal Sum of Security PKR \_\_\_\_\_ (Pak Rupees \_\_\_\_\_)

Bid Reference No. \_\_\_\_\_

KNOW ALL MEN BY THESE PRESENTS, that in pursuance of the terms of the Bid and at the request of the said Principal (Bidder) we, the Surety above named, are held and firmly bound unto \_\_\_\_\_ (hereinafter called the 'Employer') in the sum stated above for the payment of which sum well and truly to be made, we bind ourselves, our heirs, executors, administrators and successors, jointly and severally, firmly by these presents.

THE CONDITION OF THIS OBLIGATION IS SUCH, that whereas the Bidder has submitted the accompanying Bid dated \_\_\_\_\_ for \_\_\_\_\_ (Particulars of Bid) to the said Employer; and

- (1) WHEREAS, the Employer has required as a condition for considering said Bid that the Bidder furnishes a Bid Security in the above said sum to the Employer, conditioned as under: that the Bid Security shall remain in force for a period fourteen (14) days beyond the Bid Validity date i.e., upto \_\_\_\_\_.
- (2) that the Bid Securities of the Bidders except the lowest three will be returned by the Employer within twenty eight (28) days from the opening of Bids, provided a Bidder request for the return of its Bid Security, or on the expiry of original validity of Bid Security or as extended, whichever is earlier;
- (3) that the Bid Security of the lowest three Bidders comprising the successful Bidder will be returned when the successful Bidder has furnished the required Performance Security; and
- (4) that in the event of failure of the successful Bidder to furnish the required Performance Security, the entire said sum be paid immediately to the said Employer pursuant to IB.16 and IB.35 of the Instructions to Bidders for the successful Bidder's failure to perform.

NOW THEREFORE, if the successful Bidder shall, within the period specified therefor, on the prescribed form presented to him for signature enter into a formal Contract with the said Employer in accordance with his Bid as accepted and furnish within twenty eight (28) days of his being requested to do so, a Performance Security with good and sufficient surety, as may be required, upon the form prescribed by the said Employer for the faithful performance and proper fulfilment of the said Contract or in the event of non-withdrawal of the said Bid within the time specified for its validity then this obligation shall be void and of no effect, but otherwise to remain in full force and effect.



**BS-2**

PROVIDED THAT the Surety shall forthwith pay the Employer the said sum upon first written demand of the Employer (without cavil or argument) and without requiring the Employer to prove or to show grounds or reasons for such demand, notice of which shall be sent by the Employer by registered post duly addressed to the Surety at its address given above.

PROVIDED ALSO THAT the Employer shall decide, whether the Principal (Bidder) has duly performed his obligations to sign the Contract Agreement and to furnish the requisite Performance Security within the time stated above, or has defaulted in fulfilling said requirements and the Surety shall pay without objection the said sum upon demand from the Employer forthwith and without any reference to the Principal (Bidder) or any other person.

IN WITNESS WHEREOF, the above bounden Surety has executed the instrument under its seal on the date indicated above, the name and seal of the Surety being hereto affixed and these presents duly signed by its undersigned representative pursuant to authority of its governing body.

**SURETY**  
(Schedule Bank/Insurance Company)

WITNESS:

1. \_\_\_\_\_  
\_\_\_\_\_  
Corporate Secretary (Seal)

2. \_\_\_\_\_  
\_\_\_\_\_  
Name, Title & Address

Signature \_\_\_\_\_

Name \_\_\_\_\_

Title \_\_\_\_\_  
Corporate Guarantor (Seal)



PS-1

**FORM OF PERFORMANCE SECURITY**

Guarantee No. \_\_\_\_\_

Executed on \_\_\_\_\_

Expiry date \_\_\_\_\_

[Letter by the Guarantor to the Employer]

Name of Guarantor with address: \_\_\_\_\_

\_\_\_\_\_

Name of Principal (Contractor) with address: \_\_\_\_\_

Penal Sum of Security (*express in words and figures*) \_\_\_\_\_

Letter of Acceptance No. \_\_\_\_\_ Dated \_\_\_\_\_

KNOW ALL MEN BY THESE PRESENTS, that in pursuance of the terms of the Bidding Documents and above said Letter of Acceptance (hereinafter called the Documents) and at the request of the said Principal we, the Guarantor above named, are held and firmly bound unto the \_\_\_\_\_ (hereinafter called the Employer) in the penal sum of the amount stated above for the payment of which sum well and truly to be made to the said Employer, we bind ourselves, our heirs, executors, administrators and successors, jointly and severally, firmly by these presents.

THE CONDITION OF THIS OBLIGATION IS SUCH, that whereas the Principal has accepted the Employer's above said Letter of Acceptance for \_\_\_\_\_

\_\_\_\_\_ (*Name of Contract*) for the \_\_\_\_\_

\_\_\_\_\_ (*Name of Project*).

NOW THEREFORE, if the Principal (Contractor) shall well and truly perform and fulfill all the undertakings, covenants, terms and conditions of the said Documents during the original terms of the said Documents and any extensions thereof that may be granted by the Employer, with or without notice to the Guarantor, which notice is, hereby, waived and shall also well and truly perform and fulfill all the undertakings, covenants terms and conditions of the Contract and of any and all modifications of said Documents that may hereafter be made, notice of which modifications to the Guarantor being hereby waived, then, this obligation to be void; otherwise to remain in full force and virtue till all requirements of Clause 11, Defects After Taking Over, of Conditions of Contract are fulfilled.

Our total liability under this Guarantee is limited to the sum stated above and it is a condition of any liability attaching to us under this Guarantee that the claim for payment in writing shall be received by us within the validity period of this Guarantee, failing which we shall be discharged of our liability, if any, under this Guarantee.

We, \_\_\_\_\_ (the Guarantor), waiving all objections and defense under the Contract, do hereby irrevocably and independently guarantee to pay to the Employer without delay upon the Employer's first written demand without cavil or arguments



PS-2

and without requiring the Employer to prove or to show grounds or reasons for such demand any sum or sums up to the amount stated above, against the Employer's written declaration that the Principal has refused or failed to perform the obligations under the Contract which payment will be effected by the Guarantor to Employer's designated Bank & Account Number.

PROVIDED ALSO THAT the Employer shall decide, whether the Principal (Contractor) has duly performed his obligations under the Contract or has defaulted in fulfilling said obligations and the Guarantor shall pay without objection any sum or sums up to the amount stated above upon first written demand from the Employer forthwith and without any reference to the Principal or any other person.

IN WITNESS WHEREOF, the above-bounden Guarantor has executed this Instrument under its seal on the date indicated above, the name and corporate seal of the Guarantor being hereto affixed and these presents duly signed by its undersigned representative, pursuant to authority of its governing body.

**Guarantor**

(Schedule Bank/ Insurance Company)

WITNESS:

1. \_\_\_\_\_  
\_\_\_\_\_  
Corporate Secretary (Seal)

2. \_\_\_\_\_  
\_\_\_\_\_  
Name, Title & Address

Signature \_\_\_\_\_

Name \_\_\_\_\_

Title \_\_\_\_\_  
Corporate Guarantor (Seal)



## Letter of Acceptance

*[letterhead paper of the Employer]*

NAME OF CONTRACT: \_\_\_\_\_

CONTRACT NUMBER: \_\_\_\_\_

TO : \_\_\_\_\_

Date: \_\_\_\_\_

Your Reference: \_\_\_\_\_

Our Reference: \_\_\_\_\_

We thank you for your Bid dated \_\_\_\_\_ for the execution and completion of the Works comprising the above-named Contract and remedying of defects therein, all in conformity with the terms and conditions contained in the Contract.

We have pleasure in accepting your Bid for the Accepted Contract Amount of:

\_\_\_\_\_  
[currency and amount in figures]

\_\_\_\_\_  
[currency and amount in words]

In consideration of you properly and truly performing the Contract, we agree to pay you the Accepted Contract Amount or such other sums to which you may become entitled under the terms of the Contract, at such times and as prescribed by the Contract.

We acknowledge that this Letter of Acceptance creates a binding Contract between us, and we undertake to fulfil all our obligations and duties in accordance with the terms of this Contract.

Signature: \_\_\_\_\_

Signed by: \_\_\_\_\_

For and on behalf of: \_\_\_\_\_

Date: \_\_\_\_\_



## FORM OF CONTRACT AGREEMENT

THIS CONTRACT AGREEMENT (hereinafter called the "Agreement") made on the \_\_\_\_\_ day of \_\_\_\_\_ (month) 20\_\_\_\_ between \_\_\_\_\_ (hereinafter called the "Employer") of the one part and \_\_\_\_\_ (hereinafter called the "Contractor") of the other part.

WHEREAS the Employer is desirous that certain Works, viz., \_\_\_\_\_ should be executed by the Contractor and has accepted a Bid by the Contractor for the execution and completion of such Works and the remedying of any defects therein.

NOW this Agreement witnessed as follows:

1. In this Agreement words and expressions shall have the same meanings as are respectively assigned to them in the Conditions of Contract hereinafter referred to.
2. The following documents, in the order of priority, after incorporating addenda, if any, except those parts relating to Instructions to Bidders shall be deemed to form and be read and construed as part of this Agreement:
  - a) This Contract Agreement;
  - b) The Letter of Acceptance;
  - c) The Letter of Bid;
  - d) The General Conditions;
  - e) Particular Conditions / Special Conditions
  - f) The Completed Schedules to Bid including Schedule of Prices;
  - g) the JV Undertaking (if the Contractor is a JV); and
  - h) *[Employer to insert any other documents forming part of the Contract]*

The addenda/corrigenda, if any, (Excluding part relating to Instructions to Bidders along with Bidding Data) shall be deemed to have been incorporated at the appropriate places in the "Documents forming the Contract".

3. In consideration of the payments to be made by the Employer to the Contractor as hereinafter mentioned, the Contractor hereby covenants with the Employer to execute and complete the Works and remedy defects therein in conformity and in all respects with the provisions of the Contract.
4. The Employer hereby covenants to pay the Contractor, in consideration of the execution and completion of the Works as per provisions of the Contract, the Contract Price or such other sum as may become payable under the provisions of the Contract at the times and in the manner prescribed by the Contract.



IN WITNESS WHEREOF the parties hereto have caused this Agreement to be executed on the day, month and year first before written in accordance with their respective laws.

\_\_\_\_\_  
Signature of Contactor

\_\_\_\_\_  
Signature of Employer

\_\_\_\_\_  
(Seal)

\_\_\_\_\_  
(Seal)

Signed, Sealed and Delivered in the presence of:

\_\_\_\_\_  
Witness

\_\_\_\_\_  
Witness

\_\_\_\_\_  
(Name, Title and Address)

\_\_\_\_\_  
(Name, Title and Address)



**FORM OF MOBILIZATION ADVANCE GUARANTEE/ BOND**

Guarantee No. \_\_\_\_\_ Date \_\_\_\_\_

WHEREAS \_\_\_\_\_ (hereinafter called the 'Employer')

has entered into a Contract for \_\_\_\_\_  
(Particulars of Contract)

with \_\_\_\_\_ (hereinafter called the "Contractor").

AND WHEREAS, the Employer has agreed to advance to the Contractor, at the Contractor's request, an amount of Pak Rupees \_\_\_\_\_ (PKR \_\_\_\_\_) which amount shall be advanced to the Contractor as per provisions of the Contract.

AND WHEREAS, the Employer has asked the Contractor to furnish Guarantee to secure the mobilization advance for the performance of his obligations under the said Contract.

AND WHEREAS, \_\_\_\_\_

(hereinafter called the "Guarantor") at the request of the Contractor and in consideration of the Employer agreeing to make the above advance to the Contractor, has agreed to furnish the said Guarantee.

NOW, THEREFORE, the Guarantor hereby guarantees that the Contractor shall use the advance for the purpose of above mentioned Contract and if he fails and commits default in fulfilment of any of his obligations for which the advance payment is made, the Guarantor shall be liable to the Employer for payment not exceeding the aforementioned amount.

Notice in writing of any default, on the part of the Contractor, of which the Employer at his discretion of making decision, shall be given by the Employer to the Guarantor, and on such first written demand, payment shall be made by the Guarantor of all sums then due under this Guarantee without any reference to the Contractor and without any objection.

This Guarantee shall remain in force until the advance is fully adjusted against payments from the Interim Payment Certificates of the Contractor or until \_\_\_\_\_ whichever is earlier.  
(Date)

The Guarantor's liability under this Guarantee shall not in any case exceed the sum of PKR \_\_\_\_\_ (Pak Rupees \_\_\_\_\_).

This Guarantee shall remain valid up to the aforesaid date and shall be null and void after the aforesaid date or earlier if the advance made to the Contractor is fully adjusted against payments from Interim Payment Certificates of the Contractor provided that the Guarantor



agrees that the aforesaid period of validity shall be deemed to be extended if on the above mentioned date the advance payment is not fully adjusted.

Guarantor  
(Scheduled Bank/ Insurance Company)

WITNESS:

Signature \_\_\_\_\_

1. \_\_\_\_\_

Name \_\_\_\_\_

\_\_\_\_\_  
Corporate Secretary (Seal)

Title \_\_\_\_\_  
Corporate Guarantor (Seal)

2. \_\_\_\_\_

\_\_\_\_\_  
Name, Title & Address



# **CONDITIONS OF CONTRACT**



## **CONDITIONS OF CONTRACT**

The Conditions of Contract comprise two parts:

- (a) General Conditions
- (b) Particular Conditions

### **General Conditions**

These Conditions are the “General Conditions” which form part of the “FIDIC Conditions of Contract for Construction for Building and Engineering Works Designed by the Employer Second Edition (2017 Red book, Reprinted 2022 with amendments)” published by:

International Federation of Consulting Engineers  
(Fédération Internationale des Ingénieurs – Conseils) – (FIDIC)  
World Trade Center II - Geneva Airport  
P. O. Box 311  
CH-1215 Geneva 15  
Switzerland  
Email: [fidic@fidic.org](mailto:fidic@fidic.org), [fidic.pub@fidic.org](mailto:fidic.pub@fidic.org)  
Website: <https://fidic.org/bookshop>



### Particular Conditions

The Particular Conditions (PC) complement the General Conditions (GC) to specify dates, contractual requirements, and special circumstances related to the Works. The PC consists of two parts, Part A - Contract Data and Part B - Special Provisions. The provisions to be found in the Special Provisions (Particular Conditions - Part B) take precedence over the equivalent provisions found under the same Sub-Clause number(s) in the General Conditions, and the provisions of the Contract Data (Particular Conditions - Part A) take precedence over the Special Provisions (Particular Conditions - Part B).

#### Part A - Contract Data

Sub-Clause	Data to be Given	Data
1.1.27	Defects Notification Period (DNP):	365 days
1.1.31	Employer's name and address:	<b>Director</b> <b>Project Management Office</b> National University of Technology (NUTECH) Kamal Sher Khan Shaheed Road, Sector I-12, Islamabad-44000. <b>Telephone :</b> 051-5476768 5476809 Ext: 234, 219 <b>Email:</b> pm.office@nutech.edu.pk <b>Website:</b> http://nutech.edu.pk
1.1.35	Engineer's name and address:	<b>Mir Sohail Bashir</b> <b>Project Director</b> <b>Project Management Office</b> National University of Technology (NUTECH) Kamal Sher Khan Shaheed Road, Sector I-12, Islamabad-44000.
1.1.84	Time for Completion:	45 calendar days
1.3(a)(ii)	agreed methods of electronic transmission:	Emails and Fax Only as specified in above 1.1.31.
1.3(d)	address of Employer for communications:	PMO - NUTECH
	address of Engineer for communications:	Kamal Sher Khan Shaheed Road, Sector I-12, Islamabad-44000.
1.4	Contract shall be governed by the law of:	Islamic Republic of Pakistan
	ruling language:	English
	language for communications:	English



Sub-Clause	Data to be Given	Data
2.4	Employer's financial arrangements	<i>Fund from Funding Agency PSDP.</i>
3.2 (e)(ii)	Engineer's Duties and Authority	Variation resulting in an increase of the Accepted Contract Amount in excess of one percent (1%) subject to accumulative Variations not exceeding five percent (5%) of the Accepted Contract Amount.
4.2	Performance Security (as percentage of the Accepted Contract Amount in Currencies) percent: currency:	Ten percent (10%) of the quoted amount in PKR and can be provided in the shape of bank guarantee from schedule bank of Pakistan or via Insurance Companies having AA+ ratings.
4.2.1	List of Insurance Companies	<i>Same as specified in Part B – Special Conditions</i>
4.7.2	period for notification of errors in the items of reference	Twenty Eight (28) days
5.1(a)	maximum allowable accumulated value of work subcontracted (as a percentage of the Accepted Contract Amount)	N/A



Sub-Clause	Data to be Given	Data
6.5	Normal working hours on the Site	<i>Eight (08) hours per day under normal circumstances</i>
8.3	number of additional paper copies of programmes	<i>Additional copies say six (06)</i>
8.8 & 14.15(b)	Delay Damages payable for each day of delay	<i>Pak. Rs. 0.10% of the Accepted Contract Amount for delay in completion of whole of the Works</i>
8.8	maximum amount of Delay Damages	<i>Ten percent (10%) of the Accepted Contract Amount</i>
8.14	Applicability of Incentives for Early Completion	<i>“No”</i>
12.3	Percentage profit	<i>Ten percent (10%)</i>
13.4.(b)(ii)	percentage rate to be applied to Provisional Sums for overhead charges and profit	<i>Twenty Five percent (25%)</i>
14.2	Total Advance Payment	<i>Twenty percent (20%) of the Accepted Contract Amount excluding Provisional Sums payable in the currencies and proportions in which the Accepted Contract Amount is payable. This advance payment will be given in two parts. (10%, 10%)</i>
14.2.1	List of Insurance Companies	<i>Same as specified in Part B – Special Conditions</i>



Sub-Clause	Data to be Given	Data
14.2.3	percentage deductions for the repayment of the Advance Payment	Deduction shall be made at the amortization rate of 17.5% of the value of the Works executed of each IPC as provided in paragraph (i) of Sub-Clause GCC 14.3, starting from 2 <sup>nd</sup> IPC provided that the advance payment shall be completely repaid prior to the time when 90% of the Accepted Contract Amount less Provisional Sums has been certified for payment. It may be more than 17.5% in the last instalment to ensure full repayment.
14.3	period of payment	one month
14.3(b)	number of additional paper copies of Statements	<i>(06) Six Copies</i>
14.3 (iii)	percentage of retention	Five percent (5%)
14.3 (iii)	limit of Retention Money (as a percentage of the Contract Price)	Five percent (5%)
14.5(b)(i)	Plant and Materials for payment when shipped	Not Applicable
14.5(c)(i)	Plant and Materials for payment when delivered to the Site	Not Applicable
14.6.2	minimum amount of Interim Payment Certificate (IPC)	<i>Total Contract Price stated in the Letter of Acceptance / (time for completion months x 3)</i>
14.7(a)	period of payment of Advance Payment to the Contractor	14 days
14.7b(i)	period for the Employer to make interim payments to the Contractor under Sub-Clause 14.6 [Interim Payment]	14 days



Sub-Clause	Data to be Given	Data
14.7b(ii)	period for the Employer to make interim payments to the Contractor under Sub-Clause 14.13 (Final Payment)	14 days
14.7(c)	period for the Employer to make final payment to the Contractor	60 days
14.8	financing charges for delayed payment	KIBOR+3% per annum for local currency and SOFR (Secured Overnight Financing Rate) +1% per annum for foreign currency.
14.11.1(b)	number of additional paper copies of draft Final Statements	Six (06) copies of Draft Final Statements.
14.15	currencies of payment of Contract Price	PKR (local Currency of Pakistan)
14.15(c)	currencies for payment of Delay Damages	Payment of Delay Damages shall be made in the currencies specified in the Contract Data.
14.15(f)	rates of exchange	If no rates of exchange are stated in the Contract Data, they shall be those prevailing on the Base Date and published by the central bank of the Country.
17.2(d)	forces of nature, the risks of which are allocated to the Contractor	Nil
19.1	permitted deductible limits: i) insurance required for the Works ii) insurance required for Goods iii) insurance required for liability for breach of professional duty iv) insurance required against liability for fitness for purpose (if any is required) v) insurance required for injury to persons and damage to property vi) insurance required for injury to employees vii) other insurances required by Laws and by local practice	i) Nil ii) Nil iii) Nil iv) Nil v) Nil vi) Nil vii) Nil



Sub-Clause	Data to be Given	Data
19.1	Periods for submission of insurance: a) evidence of insurance b) relevant policies	N/A
19.2.1(b)	additional amount to be insured (as a percentage of the replacement value)	N/A
19.2.2	extent of insurance required for Goods  amount of insurance required for Goods	from Ex-Works (i.e., works, factory, warehouse, etc) to delivery at the Site  Full replacement value
19.2.3(a)	amount of insurance required for liability for breach of professional duty	Full replacement value of the Works to be designed by the Contractor
19.2.3(b)	insurance required against liability for fitness for purpose	Yes
19.2.3	period of insurance required for liability for breach of professional duty	Until the date of issuance of Performance Certificate
19.2.6	other insurances required by Laws and by local practice	All insurances as applicable, to the extent of execution of the project, under Federal and Provincial laws of Islamic Republic of Pakistan
21.1	time for appointment of the DAAB	Not applicable at this stage



<b>Sub-Clause</b>	<b>Data to be Given</b>	<b>Data</b>
21.1	the DAAB shall comprise	Not applicable at this stage
21.6	Rules of Arbitration	PEC Rules of Conciliation and Arbitration or Pakistan Arbitration Act of 1940, if the former is inactive.  The place of Arbitration shall be in the Employer's Office: NUTECH Islamabad, Pakistan
The following Clauses are added after Clause 21		
22	Taxes	The Contractor shall be responsible for paying any taxes imposed by the government, including income tax, withholding tax, sales tax and any other taxes on income generated from the Contract.
23	Adjustment Timeline	Adjustments, if applicable, will be made within 30 days following the employer's receipt of the contractor's notification.



## Particular Conditions

### Part B - Special Provisions

- 1.1 Definitions** 1.1.76 "Specification"  
Following is added at the end:  
"and consists of two parts i.e.,  
i) "Part A - Specific Provisions"; and  
ii) "Part B - Technical Provisions"."
- 1.2 Interpretation** "and" is deleted from the end of sub-paragraph (i) and added at the end of sub-paragraph (j).  
Sub-paragraph (k) is added:  
"(k) The word "tender" is synonymous with "bid" the word tenderer with "bidder", the words "tender documents" with "bidding documents" and "Schedule of Prices" with "Bill of Quantities", as applicable."
- 1.5 Priority of Documents** The documents listed at (a) through (k) of this Sub-Clause are deleted and substituted with the following:  
(a) the Contract Agreement;  
(b) the Letter of Acceptance;  
(c) the Letter of Bid;  
(d) the Particular Conditions Part A - Contract Data;  
(e) the Particular Conditions Part B - Special Provisions;  
(f) Specific Provisions;  
(g) the Drawings;  
(h) the completed Schedules to Bid including Bill of Quantities;  
(i) the JV Undertaking (if the Contractor is a JV); and  
(j) any other documents forming part of the Contract.  
The addenda/corrigenda, if any, shall be deemed to have been incorporated at the appropriate places in the documents forming the Contract.
- 1.6 Contract Agreement** In the last line of the 1<sup>st</sup> paragraph the text "shall be borne by the Employer" is substituted by "shall be reimbursed by the Employer to the Contractor".
- 3.1 The Engineer** In sub-paragraph (a) the text "as defined in the Pakistan Engineering Council Act, 1975 (Act No. V of 1976)" are added after the words "professional engineer".
- 3.2 Engineer's Duties and Authority** The Engineer shall obtain the consent in writing of the Employer before taking action under the following Sub-Clauses of these Conditions:  
(a) Consenting to the subcontracting of any part of the Works



- under Sub-Clause 5.1 [Subcontractors]
- (b) Any action under Sub-Clauses 8.9 [Employer's Suspension] and 8.12 [Prolonged Suspension]
  - (c) Issuance of "Taking Over Certificate" under Sub-Clause 10.1 [Taking Over the Works and Sections].
  - (d) Issuing the "Performance Certificate" under Sub-Clause 11.9 [Performance Certificate].
  - (e) Sub-Clause 13.1 [Right to Vary]: instructing a Variation, except;
    - (i) in an emergency situation as determined by the Engineer, or
    - (ii) if such a Variation would increase the Accepted Contract Amount by less than the percentage specified in the Contract Data.
  - (f) Sub-Clause 13.3 [Variation Procedure]: approving a proposal for Variation submitted by the Contractor in accordance with Sub-Clause 13.3.2 [Variation by Request for Proposal] or 13.2 [Value Engineering].
  - (g) Certifying release of second half of the Retention Money under Sub-Clause 14.9 [Release of Retention Money].
  - (h) Issuing Final Payment Certificate under Sub-Clause 14.13 [Issue of FPC].

Any such requirement shall not be applied to any action by the Engineer under Sub-Clause 3.7 [Agreement or Determination], as stated in Sub-Clause 3.2 [Engineer's Duties and Authority] of the General Conditions.

Notwithstanding the obligation, as set out above, to obtain approval, if, in the opinion of the Engineer, an emergency occurs affecting the safety of life or of the Works or of adjoining property, he may, without relieving the Contractor of any of his duties and responsibility under the Contract, instruct the Contractor to execute all such work or to do all such things as may, in the opinion of the Engineer, be necessary to abate or reduce the risk. The Contractor shall forthwith comply, despite the absence of approval of the Employer, with any such instruction of the Engineer. The Engineer shall determine an addition to the Contract Price, in respect of such instruction, in accordance with Clause 13 and shall notify the Contractor accordingly, with a copy to the Employer.

Following is added after the words "the Employer's consent is required" in 4<sup>th</sup> paragraph:

"stating that the Employer's consent has been obtained for that specified authority"



**4.1 Performance Security**

4.2.1 Contractor’s Obligations

The entity issuing the Performance Security and its form shall be as under:

The Performance Security shall be, at the option of the Contractor, issued in the prescribed form included in the Bidding Documents, by (a) a Scheduled Bank in Pakistan or (b) a foreign bank duly counter-guaranteed by a Scheduled Bank in Pakistan or (c) an Insurance Company listed in the Contract Data and rated by PACRA/VIS of rating as provided in Table below:

Accepted Contract Amount (In Eq. PKR million)	Minimum Rating of Insurance Companies
Up to 1000	A (+)
1001 to no limit	AA

In case of Joint Venture, the Performance Security shall be in the name of the Joint Venture or in the name of Lead/either firm of the JV or in ratio of shares of the individual JV partners.

Following paragraph is added at the end of this Sub-Clause:

“The amount of Performance Security shall be reduced to 50% following issue of the Taking-Over Certificate for the whole of the Works under Clause 10 of Conditions of Contract.”

**4.2 Contractor’s Representative**

In second paragraph the text “professional engineer as defined in the Pakistan Engineering Council Act, 1975 (Act No. V of 1976) (having temporary licence in case of foreign engineer under Section 12 of the Pakistan Engineering Council Act, 1975 (Act No. V of 1976)” are added after the words “qualified, experienced”.

In the 3<sup>rd</sup> paragraph the words “28 days” are substituted by “14 days”. In 2<sup>nd</sup> line of 4<sup>th</sup> paragraph the text “or appoint a replacement” is substituted by “except appointment of a suitable temporary replacement is deployed at the Site”

**4.3 Contractor’s Documents**

4.4.2 As-Built Records

First paragraph is deleted and the text in the last paragraph is substituted with the following:

“The Contractor shall furnish to the Engineer 6 copies, one reproducible and one electronic copy (provided the Engineer has made available to the Contractor editable form of the Drawings) of all Drawings amended to conform to the Works as built. In case the Engineer does not make available to the Contractor editable form of the Drawings, the Contractor shall furnish to the Engineer as-built data for incorporation in the Drawings. Upon receipt of PDF versions of the as-built drawings prepared by the Engineer, the Contractor shall furnish to the Engineer 6 copies and one reproducible of these Drawings.



The price of such Drawings shall be deemed to be included in the Contract Price.”

Following Sub-Clause is added:

4.4.4 Shop Drawings

The Contractor shall submit to the Engineer for review 3 copies of all shop and erection drawings applicable to this Contract as per provision of relevant Sub-Clause of the Contract.

**4.8 Health and Safety Obligations**

Review and approval by the Engineer shall not exceed 21 days and be construed as a complete check but will indicate only that the general method of construction and detailing is satisfactory and the Engineer’s review or approval shall not relieve the Contractor of any of his responsibilities under the Contract.

The following text is added at the end of this Sub-Clause:

In the event of work being carried out outside the normal working hours and in the event of work being carried out at night, the Contractor shall at his own cost, provide and maintain such good and sufficient light as will enable the work to proceed satisfactorily and without danger. The approaches to the Site and the Works where the night work is being carried out shall be sufficiently lighted. All arrangement adopted for such lighting shall be to the satisfaction of the Engineer.

**4.20 Progress Reports**

At the end of sub-paragraph (g) the word “and” is deleted and at the end of sub-paragraph (h) the full stop (.) is replaced with “;”, and the following new sub-paragraphs are added as:

- (i) planned programme for the execution of the Works for next 56 days to enable the Engineer to determine its programme of inspection and testing;
- (j) monthly summery of daily job record indicating weather conditions, deployment of Contractor’s Equipment, labour employment, local material procurement and material import, if any; and
- (k) salient contractual and project information.

**5.1 Subcontractors**

Add the following text at the end of paragraph (ii):

“under Schedule to Bid”

The following is added at the end of the last paragraph of Sub-Clause 5.1:

“All subcontracts relating to the Works shall include provisions which entitle the Employer to require the subcontract to be assigned to the Employer under sub-paragraph (a) of Sub-Clause 15.2.3 [After Termination].

The Contractor shall give reasonable opportunity to contractors from Islamic Republic of Pakistan for subcontracts for the Works, and endeavour to employ such contractors as Subcontractors.”



**5.2 Nominated Subcontractors**

**5.2.2 Objection to Nomination**

In sub-paragraph (c), “and” is deleted from the end of (i);  
“.” at the end of (ii) is replaced with: “, and”.  
The following is then added as (iii):

“(iii) be paid only if and when the Contractor has received from the Employer payments for sums due under the Subcontract referred to under Sub-Clause 5.2.3 [Payment to nominated Subcontractors].”

**1.1 Engagement of Staff and Labour**

The following paragraph is added at the end of the Sub-Clause:

“The Contractor shall, to the extent practicable and reasonable, employ staff (not less than 50%) and labour (not less than 85%) with appropriate qualifications and experience from sources within the Islamic Republic of Pakistan.”

**6.7 Health and Safety of Personnel**

The existing text is substituted with the following:

“In order to provide for the safety, health and welfare of persons, and for prevention of damage of any kind, all operations for the purposes of or in connection with the Contract shall be carried out in compliance with the Safety Requirements of the Government of Pakistan with such modifications thereto as the Engineer may authorize or direct and the Contractor shall take or cause to be taken such further measures and comply with such further requirements as the Engineer may determine to be reasonably necessary for such purpose. The Contractor shall also provide all other medical services and appoint a health and safety officer at Site if stated in the Specifications. In case of any fatality or serious accident, the Contractor shall, in addition, notify the Engineer immediately by the quickest available means.”

**6.8 Contractor’s Superintendence**

Insert at the end of sub-paragraph (a) of this Sub-Clause:

"or, if not, the Contractor shall make competent interpreters available during all working hours, in a number sufficient for those persons to properly perform their superintendence duties"

The following text is added at the end of this Sub-Clause:

“The Contractor’s authorized representative and his other engineers working at site shall possess valid registration with the Pakistan Engineering Council.

The Contractor’s authorized representative at Site shall be authorized to exercise adequate administrative and financial powers on behalf of the Contractor so as to achieve completion of the Works as per the Contract.”



- 6.12 Key Personnel** The following is inserted at the end of the last paragraph:  
“If any of the Key Personnel are not fluent in this language, the Contractor shall make competent interpreters available during all working hours in a number deemed sufficient by the Engineer.”

The following Sub-Clauses 6.13 to 6.26 are added at the end of Sub-Clause 6.12:

- 6.13 Foreign Personnel** The Contractor may bring in to the Country any foreign personnel who are necessary for the execution of the Works to the extent allowed by the applicable Laws. The Contractor shall ensure that these personnel are provided with the required residence visas and work permits. The Employer will, if requested by the Contractor, use all reasonable endeavours in a timely and expeditious manner to assist the Contractor in obtaining any local, state, national, or government permission required for bringing in the Contractor’s personnel.  
The Contractor shall be responsible for the return of these personnel to the place where they were recruited or to their domicile. In the event of the death in the Country of any of these personnel or members of their families, the Contractor shall similarly be responsible for making the appropriate arrangements for their return or burial.
- 6.14 Supply of Foodstuffs** The Contractor shall arrange for the provision of a sufficient supply of suitable food as may be stated in the Specification at reasonable prices for the Contractor’s Personnel for the purposes of or in connection with the Contract.
- 6.15 Supply of Water** The Contractor shall, having regard to local conditions, provide on the Site an adequate supply of drinking and other water for the use of the Contractor’s Personnel.
- 6.16 Measures against Insect and Pest Nuisance** times take the necessary precautions to protect the Contractor’s Personnel employed on the Site from insect and pest nuisance, and to reduce the danger to their health. The Contractor shall comply with all the regulations of the local health authorities, including use of appropriate insecticide.
- 6.17 Alcoholic Liquor or Drugs** The Contractor shall not, otherwise than in accordance with the Laws of the Country, import, sell, give, barter or otherwise dispose of any alcoholic liquor or drugs, or permit or allow importation, sale, gift, barter or disposal thereto by Contractor’s Personnel.
- 6.18 Arms and Ammunition** The Contractor shall not give, barter, or otherwise dispose of, to any person, any arms or ammunition of any kind, or allow Contractor’s Personnel to do so.
- 6.19 Festivals and Religious Customs** The Contractor shall respect the Country’s recognized festivals, days of rest and religious or other customs.
- 6.20 Funeral Arrangements** The Contractor shall be responsible, to the extent required by local regulations, for making any funeral arrangements for any of its local employees who may die while engaged upon the Works.
- The Contractor shall at all



- 6.21 Forced Labour** The Contractor, including its Subcontractors, shall not employ or engage forced labour which consists of any work or service, not voluntarily performed, that is exacted from an individual under threat of force or penalty, and includes any kind of involuntary or compulsory labour, such as indentured labour, bonded labour or similar labour-contracting arrangements.
- 6.22 Child Labour** The Contractor, including its Subcontractors, shall not employ or engage child labour in accordance with relevant law(s) in force in Islamic Republic of Pakistan.
- 6.23 Employment Records of Workers** The Contractor shall keep complete and accurate records of the employment of labour at the Site. The records shall include the names, ages, genders, hours worked and wages paid to all workers. These records shall be summarized on a monthly basis and submitted to the Engineer. These records shall be included in the details to be submitted by the Contractor under Sub-Clause 6.10 [*Contractor's Records*].
- 6.24 Workers' Organizations** The Contractor shall comply with the relevant labour laws of Pakistan which recognize workers' rights to form and to join workers' organizations/Trade Union of their choosing and to bargain collectively without interference.
- 6.25 Non-Discrimination and Equal Opportunity** The Contractor shall not make decisions relating to the employment or treatment of Contractor's Personnel on the basis of personal characteristics unrelated to inherent job requirements. The Contractor shall base the employment of Contractor's Personnel on the principle of equal opportunity and fair treatment, and shall not discriminate with respect to any aspects of the employment relationship, including recruitment and hiring, compensation (including wages and benefits), working conditions and terms of employment, access to training, job assignment, promotion, termination of employment or retirement, and disciplinary practices.
- Special measures of protection or assistance to remedy past discrimination or selection for a particular job based on the inherent requirements of the job shall not be deemed discrimination. The Contractor shall provide protection and assistance as necessary to ensure nondiscrimination and equal opportunity, including for specific groups such as women, persons with disabilities, migrant workers and children (of working age in accordance with Sub-Clause 6.22).
- 6.26 Epidemics** In the event of any out-break of illness of epidemic nature, the Contractor shall comply with and carry out such regulations, orders and requirements as may be made by the Government or the local medical or sanitary authorities for the purpose of overcoming the same.



- 8.1 Commencement of Works** The Contractor shall, so far as may be consistent with the Contract, make the maximum use of materials, supplies, plant and equipment indigenous to or produced or fabricated in Pakistan and services available in Pakistan provided such materials, supplies, plant, equipment and services shall be of required standard.
- 8.5 Extension of Time for Completion**

The following is added before the first paragraph:

“After signing of the Contract Agreement by both Parties,” and thereafter the word “The” is replaced with the word “the”.

The following is added after paragraph (c):

“for last five years”.

The following Sub-Clause 8.14 is added after Sub-Clause 8.13:

- 8.14 Incentives For Early Completion** If Contract Data does not state applicability of incentives for early completion, this Sub-Clause shall not apply.
- The Contractor shall be entitled subject to Sub-Clause 20.2 [*Claims for Payment and/or EOT*] to bonus payment if the Works and/or each Section is completed earlier than the Time for Completion for the Works or Section (as the case may be). The amount of bonus for early completion of the Works and/or each Section shall be upto a limit and at a rate to 50% of the relevant limit and rate of delay damages prescribed in Contract Data and shall be paid for every day which shall elapse between the relevant Date of Completion of the Works or Section and the relevant Time for Completion.
- For the purposes of calculating any bonus payment, the applicable Time for Completion stated in the Contract Data is fixed and no adjustments of this time by reason of granting an EOT will be allowed.



The following Sub-Clause 11.12 is added after Sub-Clause 11.11:

- 11.12 Supervisory Assistance During DNP** If provided under the Schedule of Prices, the Contractor shall provide supervisory assistance to the Employer during the DNP for the Works. Such supervisory assistance shall be as described in the Specification for the purpose of supporting the Employer's operation and maintenance of the Plant for the period specified in the Schedule of Prices after the Date of Completion.
- 12.2 Method of Measurement** The following paragraph is added at the end of the Sub-Clause:  
"Summary of measured quantity for payment shall be delineated item-wise under four heads namely; "Schedule of Prices Quantity", "Quantity Executed To-date", "Quantity Certified Previously" and "Net Quantity Executed under this Certificate".
- 12.3 Valuation of the Works** The following text is added at the end of fifth paragraph of the Sub-Clause:  
"Sum of overhead charges and profit for sub-paragraph (a) shall be Twenty Five percent (25%)".
- 13.6 Adjustments for Changes in Laws** The following paragraph is added at the end of the Sub-Clause:  
"Notwithstanding the foregoing, the Contractor shall not be entitled to an extension of time if the relevant delay has already been taken into account in the determination of a previous extension of time and such Cost shall not be separately paid if the same shall already have been taken into account in the indexing of any inputs to the Table of Adjustment Data in accordance with the provisions of Sub-Clause 13.7 [*Adjustments for Changes in Cost*]."
- 14.1 The Contract Price** The following is added at the end of the Sub-Clause:  
"Notwithstanding the provisions of subparagraph (b), Contractor's Equipment, including essential spare parts, imported by the Contractor for the sole purpose of executing the Contract shall be temporarily exempt from the payment of import duties and taxes upon initial importation, provided the Contractor shall post with the customs authorities at the port of entry an approved re-export bond or bank guarantee, valid until the Time for Completion plus six months, in an amount equal to the full import duties and taxes which would be payable on the assessed imported value of such Contractor's Equipment and



spare parts, and callable in the event the Contractor's Equipment is not re-exported from the Country on completion of the Contract. A copy of the bond or bank guarantee endorsed by the customs authorities shall be provided by the Contractor to the Employer upon the importation of individual items of Contractor's Equipment and spare parts. Upon re-export of individual items of Contractor's Equipment or spare parts, or upon the completion of the Contract, the Contractor shall prepare, for approval by the customs authorities, an assessment of the residual value of the Contractor's Equipment and spare part to be re-exported, based on the depreciation scale(s) and other criteria used by the customs authorities for such purposes under the provisions of the applicable Laws. Import duties and taxes shall be due and payable to the customs authorities by the Contractor on (a) the difference between the initial imported value and the residual value of the Contractor's Equipment and spare parts to re-exported; and (b) on the initial imported value of the Contractor's Equipment and spare parts remaining in the Country after completion of the Contract. Upon payment of such dues within 28 days of being invoiced, the bond or bank guarantee shall be reduced or released accordingly; otherwise the security shall be called in the full amount remaining."

*[The Employer may change or delete this Sub-Clause as per Project requirements]*

## 14.2 Advance Payment

### 14.2.1 Advance Payment Guarantee

The entity issuing the Advance Payment Guarantee and its form shall be as under:

The Advance Payment Guarantee shall be in the form of Guarantee issued by (a) a Scheduled Bank in Pakistan or (b) a foreign bank duly counter-guaranteed by a Scheduled Bank in Pakistan or (c) an Insurance Company listed in the Contract Data and rated by PACRA/VIS of rating as provided in Table below:

Accepted Contract Amount (In Eq. million PKR)	Minimum Rating of Insurance Companies
Up to 1000	A (+)
1001 to no limit	AA

In case of Joint Venture, the Advance Payment Guarantee(s) shall be in the name of the Joint Venture or in the name of Lead/either firm of the JV or in ratio of shares of the individual JV partners.



- 14.5 Issue of IPC**                      14.6.1 The IPC  
In the first line of the 1<sup>st</sup> paragraph the words “28 days” are substituted by “14 days”.
- 14.6 Payment**                              The words “or through crossed cheque in favour of the Contractor or JV partners. The Payment to JV partners shall be made at the request of the Joint Ventures in the ratio of their shares specified by them” are added at the end of the Sub-Clause.
- 14.7 Delayed Payment**                In the first paragraph, third line, the words “compounded monthly” are deleted.  
  
The text of 2nd paragraph is deleted and substituted with the following:  
  
“The Employer shall pay to the Contractor compensation at the rate stated in the Contract Data.”
- 15.2 Termination for Contractor’s Default**      15.2.1 Notice  
Following text is added at the end of sub-paragraph (h) of this Sub-Clause:  
  
“For the purposes of this Contract, corrupt and fraudulent practices have been defined in Public Procurement Rules 2004.”
- 15.2.3 After Termination  
The word “and” at the end of sub-paragraph (ii) of paragraph (b) is deleted the following paragraph is added after sub-paragraph (iii):  
  
“(iv) all Employer-Supplied Materials and/or Employer’s Equipment made available to the Contractor in accordance with Sub-Clause 2.6 [*Employer-Supplied Materials and Employer’s Equipment*], and”



- 15.4 Payment after Termination** The following text is added at the end of this Sub-Clause:  
"The Employer shall be entitled to sell any of the Contractor's Equipment, Temporary Works and unused materials and apply the proceeds of sale towards payment of any debt due from the Contractor to the Employer under this Clause including any outstanding payments to the Subcontractors.
- 16.2 Termination by Contractor** 16.2.1 Notice  
The sub-paragraph (j) is deleted in its entirety.  
At the end of sub-paragraph (i) "; or" is replaced with "." and at the end of sub-paragraph (h) ";" is replaced with "; or".  
In sub-paragraph (f) "84 days" are replaced with "180 days" and text "for reasons not attributable to the Contractor" is added at the end.
- 16.3 Contractor's Obligations After Termination** Sub-paragraph (c) is deleted and replaced with:  
"(c) deliver to the Engineer all Employer-Supplied Materials and/or Employer's Equipment made available to the Contractor in accordance with Sub-Clause 2.6 [*Employer-Supplied Materials and Employer's Equipment*]; and  
(d) remove all other Goods from the Site, except as necessary for safety, and leave the Site."
- 17.1 Responsibility for Care of the Works** After the two instances of "Goods" in the last paragraph, the words "Employer-Supplied Materials and/or Employer's Equipment" are added.
- The following Sub-Clause 17.7 is added after Sub-Clause 17.6:
- 17.7 Use of Employer's Accommodation/Facilities** The Contractor shall take full responsibility for the care of the items of the Employer's facilities and/or accommodation, if any, as detailed in the Specification, from the date of use and/or occupation by the Contractor until the date on which such use and/or occupation is re-vested in the Employer.  
If any loss or damage happens to any of the above items during a time while the Contractor is responsible for its care, arising from any cause other than a cause for which the Employer is responsible or liable, the Contractor shall promptly rectify the loss or damage at the Contractor's risk and cost.
- 18.1 Exceptional Events** The words "or disorder" are replaced with "disorder or sabotage" in sub-paragraph (c) of the Clause.
- 18.4 Consequences of an Exceptional Event** The following is added at the end of sub-paragraph (b) after deleting the ".":  
", including the costs of rectifying or replacing the Works and/or Goods damaged or destroyed by Exceptional Events, to the extent they are not indemnified through the insurance policy referred to in Sub-Clause 19.2 [*Insurance to be provided by the Contractor*]."
- 18.5 Optional Termination** In sub-paragraph (c), the words "and necessarily" are added after the words "was reasonably".



**19.1 General Requirements** Following text is added at the end of first paragraph:

“The Contractor shall immediately after the date of the Letter of Acceptance submit the draft of insurance policies for the Employer’s consent.”

Following text is added at the end of third paragraph:

“The Contractor shall, within the respective periods stated in the Contract Data submit to the Engineer and the Employer a) evidence that the insurances described in this Clause have been effected, and b) copies of policies of the insurances described in Sub-Clauses 19.2.1, 19.2.4 and 19.2.5.”

**19.2 Insurance to be Provided by the Contractor**

19.2.5 Injury to employees

The words “sickness, disease” are deleted in the third line of first paragraph.

The following Sub-Clause is added after Sub-Clause 19.2.6:

19.2.7 Insurance Company

“The Contractor shall be obliged to place all insurances described in this Clause with insurers listed in the Contract Data and rated by PACRA/VIS of rating as provided in Table below:



Accepted Contract Amount (In Eq. million PKR)	Minimum Rating of Insurance Companies
Up to 1000	A (+)
1001 to no limit	AA

**21.6 Arbitration**

The word “international” is deleted in the sixth line of first paragraph. The text of sub-paragraph (a) is substituted with the following:

“the Dispute shall be finally settled under the Rules of Arbitration, specified in the Contract Data;”

The following Clauses are added after Clause 21

**22 Custom Duty**

*[Employer may incorporate provisions where applicable. However, in order to make the bid more balanced, the payment of Customs Duties should be the responsibility of the Employer.]*

**23 Taxes**

The Contractor, Subcontractors and their employees shall be liable to pay income tax, withholding tax, super tax and other taxes on income arising out of the Contract. The rates and prices as stated in the contract shall be deemed to cover all such taxes.

**24 Integrity Part**

If it is found and established at any stage that the Contractor or any of his Subcontractors, agents or servants have violated or involved in violation of the Integrity Pact signed by the Contractor then the Employer shall be entitled to :

- (a) recover from the Contractor an amount equivalent to ten times the sum of any commission, gratification, bribe, finder’s fee or kickback given by the Contractor or any of his Subcontractors, agent or servants;
- (b) terminate the Contract; and
- (c) recover from the Contractor any loss or damage to the Employer as a result of such termination or of any other corrupt business practices of the Contractor or any of his Subcontractors, agent or servants.

The termination under sub-paragraph (b) of this Sub-Clause shall proceed in the manner prescribed under Sub-Clause 15.1 to 15.4 and the payment under Sub-Clause 15.4 shall be made after having deducted the amounts due to the Employer under sub- paragraph (a) and (c) of this Sub-Clause.



# **SPECIAL PROVISIONS**

## **Term of Reference (TOR's)**

### **1. Payment Terms**

- 1.1. Advance Payment against bank guarantee = 20%  
*advance will be given in two parts (10% each)*
- 1.2. Upon installation, testing and commissioning = 20%
- 1.3. Retention Money = 5%
- 1.4. Remaining payment will be given on running IPCs

### **2. Secure Advance**

- Secure Advance will be given upon decision of Engineer In charge.

### **3. Special Conditions**

1. Fully compliance with the required technical (schedule + General) specifications.
2. A minimum of 01 Year comprehensive warranty of the equipment from Authorized Manufacturer against all type of parts and services.
3. If any of the given specifications/parameters do not meet the required specifications, the offer will not be considered and shall summarily be rejected by technical Committee.
4. Samples shall be given at the stage of bidding for the respective items.
5. Placing, Laying, Installation, Testing & Commissioning is included in almost every items of BoQs.
6. In case of a successful bidder, who repudiates the contract or fails to furnish performance guarantee and as the case may shall proceed for blacklisting and the work order will be placed to the Next Successful Bidder or from the alternative sources at the cost/risk of the concerned firm.
7. All Participant should have its local office in territory of Islamabad / Rawalpindi / Lahore.
8. In case of JV, lead partner should be an authorized distributor / manufacturer.
9. All Participant should have its own established Operation and Maintenance department with availability of tools, spare parts and technical persons.
10. Only original equipment manufacturer / authorized distributors are allowed to participate.
11. Authorized Distributors Certificate from approved / authorized manufacturer is mandatory.
12. All taxes will be borne by contractor.

**SUBJECT:**

**:SUMMARY FOR LOT-1, 2, 3:**

<b>S/N</b>	<b>LOT DESCRIPTION</b>	<b>LOT</b>	<b>Total AMOUNT WITH GST</b>
1	Copper & Fiber Passive LAN Equipment (Data, Telephone, Wifi, CCTV Points	1	
2	Network Switches, CCTV, & UPS System	2	
3	Public Address System, Fire Alarm System	3	
<b>GRAND TOTAL WITH GST</b>			

**Subject: LOT 1 :Copper & Fiber Passive LAN Equipment (Data, Telephone, Wifi, CCTV Points**

S/N	Items/Description	Unit	Qty	Unit Price without GST	Unit Price with GST	Total Price with GST
1	Providing and Laying of Cat-7 S/FTP Cable, Pure Copper, 10G Supported * Conductor Diameter: AWG 23 (0.56±0.005mm) * Insulation Diameter: 1.03±0.03 mm * Number of Pairs: 4 pairs * Conductor Type: Solid Bare Copper (i-Connect/UK/Panduit/Schneider or Equivalent)	Meter	70000			
2	Single Port Face Plate without Shuttered, UK Style 86x86mm with Top Label Holder, Color Signal White Mandatory Features: • Single Port Without Shuttered Face Plate with Label holder with white label strip and transparent hinged cover • Keystone Fixing • UK standard single gang faceplate with 86 x 86 mm dimensions • Color Signal White • Compatible with all keystone jacks (Shielded/unshielded, Cat. 5E/6/6A, with/without shutters) • Two mounting screws included (i-Connect/UK/Panduit/Schneider or Equivalent)	Nos	1582			
3	Back Box for Face Plate (Steel & PVC)	Nos	1582			
4	S/FTP Cat-6A Toolless Shuttered Shielded I/O, White, 10G Supported Mandatory Features: • Toolless Assembly • S/FTP I/O, Shielded • Shuttered I/O • Keystone Fixing (i-Connect/UK/Panduit/Schneider or Equivalent)	Nos	1582			
5	24 Port Patch Panel with Top Label Holder Including S/FTP Cat-6A Toolless Shuttered Shielded I/Os, Fully Loaded, 10G Supported Mandatory Features: • 24 Port Patch Panel with Top Label Holder • S/FTP I/O, Shielded • Toolless Assembly • Shuttered I/O • Keystone Fixing (i-Connect/UK/Panduit/Schneider or Equivalent)	Nos	84			

6	<p>Cable Manager, 1U, PVC  Made of plastic.  1U management hoops with horizontal &amp; vertical options.  Includes cage nut set for EIA 19" rack/cabinet mount.  Lightweight, easy to install/remove.  Comes in black color with 5 removable rings for cable configuration.  Used with patch panels in rack/cabinet mounts  (i-Connect/UK/Panduit/Schneider or Equivalent)</p>	Nos	120			
---	------------------------------------------------------------------------------------------------------------------------------------------------------------------------------------------------------------------------------------------------------------------------------------------------------------------------------------------------------------------------------------------------------------	-----	-----	--	--	--

7	F/UTP Cat-6A RJ45 to RJ45 Patch Cord, PVC, 1-Meter, 10G Supported (i-Connect/UK/Panduit/Schneider or Equivalent)	Nos	1582			
8	F/UTP Cat-6A RJ45 to RJ45 Patch Cord, PVC, 3-Meter, 10G Supported (i-Connect/UK/Panduit/Schneider or Equivalent)	Nos	1582			
9	Providing and Laying of 12 Core Optical Fiber Cable, Single Mode, (i-Connect/UK/Panduit/Schneider or Equivalent)	Meter	8000			
10	24 Port LC Type Rack Mounted ODF with Pigtails, Adapters, Sleeves, Splicing Trays, Fully Loaded, Single Mode, (i-Connect/UK/Panduit/Schneider or Equivalent)	Nos	26			
11	48 Port LC Type Rack Mounted ODF with Pigtails, Adapters, Sleeves, Splicing Trays, Fully Loaded, Single Mode (i-Connect/UK/Panduit/Schneider or Equivalent)	Nos	13			
12	LC-LC Optical Fiber Patch Cord, Single Mode, Duplex, 3-Meter (i-Connect/UK/Panduit/Schneider or Equivalent)	Nos	216			
13	LC-LC Optical Fiber Patch Cord, Single Mode, Duplex, 10-Meter (i-Connect/UK/Panduit/Schneider or Equivalent)	Nos	15			
14	42U 800x1000 Server Floor Standing Rack, Front Perforated, 4-Fans, 2-Fix, 1-2x PDU (For Floor IT Rooms) Sliding Trays, Back Double Door, <ul style="list-style-type: none"> <li>• Flat vented front single door with handle lock.</li> <li>• Double flat vented rear doors with handle lock.</li> <li>• Flat door border and arc door edge treatment.</li> <li>• Removable side doors to enable easy access.</li> <li>• Top and bottom wire path holes.</li> <li>• Max load capacity 1000kg.</li> <li>• Made of SPCC quality cold rolled steel material.</li> <li>• Mounting rails 2.0mm and mounting angle 1.2 - 1.5mm.</li> <li>• IP20 standard protections.</li> <li>• Degreasing, acid pickling, Parkerizing surface finishing.</li> </ul> Compliance: Complies with ANSI/EIA RS-310-D, IEC297-2, DIN41491; PART1, DIN41494; PART7, ETSI (i-Connect/UK/HP/Dell or Equivalent)	Nos	7			

15	<p>42U 800x1000 Server Floor Standing Rack, Front Perforated, 4-Fans, 2-Fix, 1-2x PDU (For Control Room) Sliding Trays, Back Double Door,</p> <ul style="list-style-type: none"> <li>• Flat vented front single door with handle lock.</li> <li>• Double flat vented rear doors with handle lock.</li> <li>• Flat door border and arc door edge treatment.</li> <li>• Removable side doors to enable easy access.</li> <li>• Top and bottom wire path holes.</li> <li>• Max load capacity 1000kg.</li> <li>• Made of SPCC quality cold rolled steel material.</li> <li>• Mounting rails 2.0mm and mounting angle 1.2 - 1.5mm.</li> <li>• IP20 standard protections.</li> <li>• Degreasing, acid pickling, Parkerizing surface finishing.</li> </ul> <p>Compliance: Complies with ANSI/EIA RS-310-D, IEC297-2, DIN41491; PART1, DIN41494; PART7, ETSI (i-Connect/UK/HP/Dell or Equivalent)</p>	Nos	1			
16	<p>18U 600x600 Wall Mounted Cabinet with Fan &amp; 1-PDU</p> <ul style="list-style-type: none"> <li>• Front glass door, blank panel with small round lock.</li> <li>• Removable side doors with plastic fasteners, lock is optional.</li> <li>• Rear solid metal door, with small round lock.</li> <li>• RU marking on front and rear mounting rails</li> <li>• Top and bottom wire path.</li> <li>• Front and rear hinge can be installed at either side.</li> <li>• Heavy duty type hinge, 120 degrees open angle.</li> <li>• Earthing bolts.</li> <li>• Loading capacity: 60kg.</li> <li>• Thickness: Mounting profile: 1.5mm; mounting angle: 1.0mm; other: 1.2mm;</li> <li>• Degree of protection: IP20</li> <li>• Surface finish: Degreasing, Pickling, Phosphating, Powder Coated, static</li> <li>• electricity plastic painting.</li> <li>• Top fan tray has 2~4 fans for cooling.</li> </ul> <p>Compliance: Complies with ANSI/EIA RS-310-D, IEC297-2, DIN41491; PART1, DIN41494; PART7, GB/T3047.2-92.</p>	Nos	7			

17	<p>15U 600x600 Wall Mounted Cabinet with Fan &amp; 1-PDU</p> <ul style="list-style-type: none"> <li>• Front glass door, blank panel with small round lock.</li> <li>• Removable side doors with plastic fasteners, lock is optional.</li> <li>• Rear solid metal door, with small round lock.</li> <li>• RU marking on front and rear mounting rails</li> <li>• Top and bottom wire path.</li> <li>• Front and rear hinge can be installed at either side.</li> <li>• Heavy duty type hinge, 120 degrees open angle.</li> <li>• Earthing bolts.</li> <li>• Loading capacity: 60kg.</li> <li>• Thickness: Mounting profile: 1.5mm; mounting angle: 1.0mm; other: 1.2mm;</li> <li>• Degree of protection: IP20</li> <li>• Surface finish: Degreasing, Pickling, Phosphating, Powder Coated, static</li> <li>• electricity plastic painting.</li> <li>• Top fan tray has 2~4 fans for cooling.</li> </ul> <p>Compliance: Complies with ANSI/EIA RS-310-D, IEC297-2, DIN41491; PART1, DIN41494; PART7, GB/T3047.2-92. (i. Connect/UK/HP/Dell or Equivalent)</p>	Nos	5			
18	<p>9U 600x600 Wall Mounted Cabinet with Fan &amp; 1-PDU</p> <ul style="list-style-type: none"> <li>• Front glass door, blank panel with small round lock.</li> <li>• Removable side doors with plastic fasteners, lock is optional.</li> <li>• Rear solid metal door, with small round lock.</li> <li>• RU marking on front and rear mounting rails</li> <li>• Top and bottom wire path.</li> <li>• Front and rear hinge can be installed at either side.</li> <li>• Heavy duty type hinge, 120 degrees open angle.</li> <li>• Earthing bolts.</li> <li>• Loading capacity: 60kg.</li> <li>• Thickness: Mounting profile: 1.5mm; mounting angle: 1.0mm; other: 1.2mm;</li> <li>• Degree of protection: IP20</li> <li>• Surface finish: Degreasing, Pickling, Phosphating, Powder Coated, static</li> <li>• electricity plastic painting.</li> <li>• Top fan tray has 2~4 fans for cooling.</li> </ul> <p>Compliance: Complies with ANSI/EIA RS-310-D, IEC297-2, DIN41491; PART1, DIN41494; PART7, GB/T3047.2-92.</p>	Nos	7			
19	<p>Supply and Installation of Cable Tray 18SWG 12x3" with Cover all Accessories and Complete Fitting Material Road, Anchor Bolt, Rawal Bolt ,Hanging Patti and Complete Nut Bolt (Local)</p>	Rft	2800			

20	Supply and Installation of Cable Tray 18SWG 9x3" with Cover all Accessories and Complete Fitting Material Road, Anchor Bolt, Rawal Bolt ,Hanging Patti and Complete Nut Bolt (Local)	Rft	450			
21	Supply and Installation of Cable Tray 18SWG 6x3" with Cover all Accessories and Complete Fitting Material Road, Anchor Bolt, Rawal Bolt ,Hanging Patti and Complete Nut Bolt (Local)	Rft	450			
22	Providing and Laying of PVC Pipe 1" with Fixing Material (Adamjee/Turk Plastor Equivalent)	Rft	19500			
23	Providing and Laying of PVC Pipe 1" Flexible with Fixing Material (Adamjee/Turk Plast or Equivalent)	Rft	3000			
24	Providing and Laying of PVC Pipe 2" with Fixing Material (Adamjee/Turk Plast or Equivalent)	Rft	500			
25	PVC Duct 16x38 with Fixing Material (Adamjee/Turk Plast or Equivalent )	Rft	100			
26	PVC Duct 40x40 with Fixing Material (Adamjee/Turk Plast or Equivalent )	Rft	200			
27	PVC Duct 60x60 with Fixing Material (Adamjee/Turk Plast or Equivalent)	Rft	4000			
28	Floor Boxes 12"x12" For Computer Labs and Podium Points	Nos	10			
29	HDMI Face Plate Imported	Nos	49			
<b>Services Part</b>						
31	Termination, Commissioning, Haggig of Material, Tagging Face Plate End and Patch Panel End, Complete Racks Installation Charges	Per Point	1582			
32	Cat-6A S/FTP Cable Fluke Testing with Fluke Meter DTX-1800 or Above Calibrated	Per Point	1582			
34	Fiber Splicing with OTDR (Calibrated) Testing with Calibrated Equipment	Per Splice	1248			
<b>Total Amount with GST</b>						

**Subject: LOT 2: Network Switches, CCTV, & UPS System**

S/N	Items/Description	Unit	Qty	Unit Price without GST	Unit Price with GST	Total Price with GST
<b>Network Switches Part</b>						
1	Supply, Installation & Configuration of Ethernet Switch with 24*10/100/1000BASE-T PoE+ Ports, 4*100/1000BASE-X SFP Combo Ports, and 4*1G/10GBASE-X SFP+ Ports,(AC) (H3C/Huawei/Cisco or Equivalent) AC Jumper Cord,2.0m,1.0mm^2,Black,C14C(3P)STM250V10A,227 IEC 53(RVV)&H05VV-F&SJT,C13,CCC/UL/EU/KC Console Cable,1.8m,RJ45P,UL2725(3C28AWG),USB AP 3- Years NBD Standard Equipment warranty from OEM	Nos	7			
2	Supply, Installation & Configuration of Ethernet Switch with 48*10/100/1000BASE-T PoE+ Ports and 4*1G/10GBASE-X SFP+ Ports,(AC) (H3C/Huawei/Cisco or Equivalent) AC Jumper Cord,2.0m,1.0mm^2,Black,C14C(3P)STM250V10A,227 IEC 53(RVV)&H05VV-F&SJT,C13,CCC/UL/EU/KC Console Cable,1.8m,RJ45P,UL2725(3C28AWG),USB AP 3- Years NBD Standard Equipment warranty from OEM	Nos	8			
3	Supply, Installation & Configuration of Ethernet Switch with 24*10/100/1000BASE-T Ports and 4*1G/10G BASE-X SFP+ Ports,(AC) (H3C/Huawei/Cisco or Equivalent) AC Jumper Cord,2.0m,1.0mm^2,Black,C14C(3P)STM250V10A,227 IEC 53(RVV)&H05VV-F&SJT,C13,CCC/UL/EU/KC Console Cable,1.8m,RJ45P,UL2725(3C28AWG),USB AP 3- Years NBD Standard Equipment warranty from OEM	Nos	7			
4	Supply, Installation & Configuration of Ethernet Switch with 48*10/100/1000BASE-T Ports and 4*1G/10G BASE-X SFP+ Ports,(AC) (H3C/Huawei/Cisco or Equivalent) AC Jumper Cord,2.0m,1.0mm^2,Black,C14C(3P)STM250V10A,227 IEC 53(RVV)&H05VV-F&SJT,C13,CCC/UL/EU/KC Console Cable,1.8m,RJ45P,UL2725(3C28AWG),USB AP 3- Years NBD Standard Equipment warranty from OEM	Nos	7			
5	Supply, Installation & Configuration of 48 Port Aggregation Switch with 48*1G/10G SFP+ Ports, 4*40G/100G QSFP28 Ports ,and 2*Slots, Without Power Supplies (H3C/Huawei/Cisco or Equivalent) AC Jumper Cord,2.0m,1.0mm^2,Black,C14C(3P)STM250V10A,227 IEC 53(RVV)&H05VV-F&SJT,C13,CCC/UL/EU/KC Console Cable,1.8m,RJ45P,UL2725(3C28AWG),USB AP QSFP+ 40GBASE Optical Transceiver Module (850nm,300m,CSR4,Support 40G to 4*10G)	Nos	2			

	450W AC Power Supply Module (Power Panel Side Exhaust Airflow)					
	Asset-Manageable Fan Module (Fan Panel Side Exhaust Airflow)					
	3- Years NBD Standard Equipment warranty from OEM					
6	Supply, Installation & Configuration 10G SFP+ Module(850nm,300m,LC) (H3C/Huawei/Cisco or Equivalent)	Nos	154			
7	Supply, Installation & Configuration of Wifi Controller (H3C/Huawei/Cisco or Equivalent)	Nos	1			
	Ethernet Interface Expansion Module(8GE+2*SFP+)					
	250W AC Power Supply					
	Enhanced Access Controller License,32 APs,for Verticals,for V7V9					
	Enhanced Access Controller License,64 APs,for Verticals,for V7V9					
	3- Years NBD Standard Equipment warranty from OEM					
8	Supply, Installation & Configuration AP in Door Internal Antennas 4 Streams Dual Radio 802.11be/ax/ac/n Access Point(1*GE+1*10GE+1*10G PSFP),FIT (H3C/Huawei/Cisco or Equivalent)	Nos	8			
	3- Years NBD Standard Equipment warranty from OEM					
9	Supply, Installation & Configuration of AP Out Door Internal Antennas 6 Streams Triple Radio 802.11be/ax/ac/n Industrial Access Point(1*GE+1*10GE+1*10G PSFP),FIT (H3C/Huawei/Cisco or Equivalent)	Nos	1			
	55V Power Supply 60W PoE Injector					
	Outdoor Mounting Bracket,WA7300X Outdoor Series,Structure					
	Water-proof cover,WA5300X Outdoor Series-M25*1.5,10PCS					
	Extended Waterproof Connector,WA7300X Outdoor					
	3- Years NBD Standard Equipment warranty from OEM					
10	Supply, Installation & Configuration of Firewall Appliance with 16*GE Copper,4*SFP Fiber,6*SFP Plus,4*Combo,1*Management Port,2*USB,1*Console,and 2*Slots (H3C/Huawei/Cisco or Equivalent)	Nos	1			
	Console Cable,1.8m,RJ45P,UL2725(3C28AWG),USB AP					
	Series,480GB 2.5inch SATA SSD HardDisk Module					
	150W AC Power Supply					
	AC Jumper Cord,2.0m,1.0mm^2,Black,C14C(3P)STM250V10A,227 IEC 53(RVV)&H05VV-F&SJT,C13,CCC/UL/EU/KC					
	Firewall TI/ACG/IPS/AV/URL Signature Update License,1 Year					
	Adaptive Operations Expert Day, INT					
<b>Total Price with GST</b>						

CCTV Active Part						
1	Supply, Installation & Configuration of Dome camera 4MP ColorVu with Smart Hybrid Light Fixed Bullet Network Camera, Smart Hybrid Light: advanced technology with long range, Built-in microphone, 1/3" Progressive Scan CMOS, Up to 30m Supplement Light Range, 20 fps (2560 × 1440), 25 fps (1920 × 1080, 1280 × 720), 120 dB WDR, BLC, HLC, 3D DNR, Water and dust resistant (IP67). (Hikvision/Dahua, HT-Net/Australia or Equivalent)	Nos	24			
2	Supply, Installation & Configuration of Bullet Camera 4MP ColorVu with Smart Hybrid Light Fixed Bullet Network Camera, Smart Hybrid Light: advanced technology with long range, Built-in microphone, 1/3" Progressive Scan CMOS, Up to 30m Supplement Light Range, 20 fps (2560 × 1440), 25 fps (1920 × 1080, 1280 × 720), 120 dB WDR, BLC, HLC, 3D DNR, Water and dust resistant (IP67). (Hikvision/Dahua, HT-Net/Australia or Equivalent)	Nos	24			
3	Supply, Installation & Configuration of PTZ Camera 4MP DS-2DE7A432IW-AEB (T5) 25X Powered by Dark Fighter IR Network Speed Dome, focuses on human and vehicle targets classification based on deep learning, Support face capture, 1/2.8" progressive scan CMOS, Powered-by-Dark Fighter technology, 25× optical zoom and 16× digital zoom, up to 100 m IR distance, Support H.265+/H.265 video compression, Color: 0.005 Lux @ (F1.6, AGC ON), 120 dB WDR, Digital defog, BLC, HLC, 3D DNR, Built-in memory card slot, IP66. (Hikvision/Dahua, HT-Net/Australia or Equivalent)	Nos	4			
4	Supply, Installation & Configuration of PTZ Controllar Network Keyboard, Flexible 4-axis joystick, 128 × 64 dot-matrix screen, Supports various cameras, NVRs, DVRs, Supports Web configuration, Supports PTZ control, settings and calling of presets and patrols, Control Method: Network control and serial control, RJ45 10 M/100 M self-adaptive Ethernet interface × 1, RS-232 × 1, RS-485 × 1, RS-422 × 1, USB 2.0 x1, 12 VDC. (Hikvision/Dahua, HT-Net/Australia or Equivalent)	Nos	1			
5	Supply, Installation & Configuration of 64 Channel AcuSense NVR, Intelligent analytics based on deep learning algorithm, Up to 4-ch perimeter protection, Up to 4-ch facial recognition for video stream, or up to 8-ch facial recognition for face picture, Incoming Bandwidth: 384 Mbps, Outgoing Bandwidth: 256 Mbps, Up to 8-ch IP speakers can be connected, Motion Detection 2.0 on all channel, HDMI1/VGA1 simultaneous output, HDMI2/VGA2 simultaneous output, HDMI1/HDMI2 independent output, Support ANPR Cameras attributes, RAID0, RAID1, RAID5, RAID6, RAID10 Support global hot spare, 8 SATA interfaces, 100 to 240 VAC, 50 to 60 Hz, ≤ 30 W (without HDD) (Hikvision/Dahua, HT-Net/Australia or Equivalent)	Nos	1			

6	Supply, Installation of Western Digital 4TB WD Surveillance Internal Hard Drive HDD	Nos	4			
7	Supply, Installation of 55" Led TV 4K Supported : TCL/Haier or Equivalent	Nos	1			
8	Supply, Installation of Wirless Mouse	Nos	1			
9	Supply, Installation of HDMI Cable 15 to 20 Meter 4K Supported	Nos	1			
10	Supply, Installation ofPTZ Pole 5 to 10 feet With Fixing Material	Nos	4			
<b>Total Price with GST</b>						
<b>UPS 10KVA</b>						
1	Supply, Installation & Configration of Branded Pure sine wave double conversion UPS., 10KVA/10KW. Tower/Rack Type. (Solution should be according to meet the 100% Capacity 10KW), 1 Phase input/output, External Batteries for 30 Minutes Backup @ 50% load (12V-9Ah x 32), Input voltage 220 V (3-phase+neutral +PE) Output voltage 220 V, Efficiency: Double conversion mode up to 95%, Protection: Overload, short-circuit, over-Temperature, serge protection. (i-Power/UK/APC or Equivalent)	Nos	3			
<b>Total Amount with GST</b>						
<b>Grand Total with GST</b>						

**Subject: LOT 3: Fire Alarm System**

S/N	Items/Description	Unit	Qty	Unit Price without GST	Unit Price with GST	Total Price with GST
<b>Fire Alarm System</b>						
1	Supply, Installation & Configuration of Addressable 8 Loop Fire Alarm Control Panel (Gent by Hanywell, Eton or Equivalent)	Nos	1			
2	Supply, Installation & Configuration of Addressable Optical Smoke Detector (Gent by Hanywell, Eton or Equivalent)	Nos	100			
3	Supply, Installation & Configuration of Addressable Heat Detector (Gent by Hanywel, Eton or Equivalent)	Nos	3			
4	Supply, Installation & Configuration of Addressable Sounder + Flasher (Gent by Hanywell, Eton or Equivalent)	Nos	12			
5	Supply, Installation & Configuration of Addressable Manual Call Point/Break Glass (Gent by Hanywell, Eton or Equivalent)	Nos	12			
6	Supply, Installation of 2 Core Fire Alarm Cable (Lower Ground to Third Floor) (Belden or Equivalent)	Meter	7000			
7	Supply, Installation of PVC Pipe 1" With Fixing Material (Plasco, Beta, Adamjee, Turak Plast )	Meter	1			
<b>Total Amount</b>						

# 12 Core Fiber Cable Primary & Secondary Link Single Mode Single Line Drawing

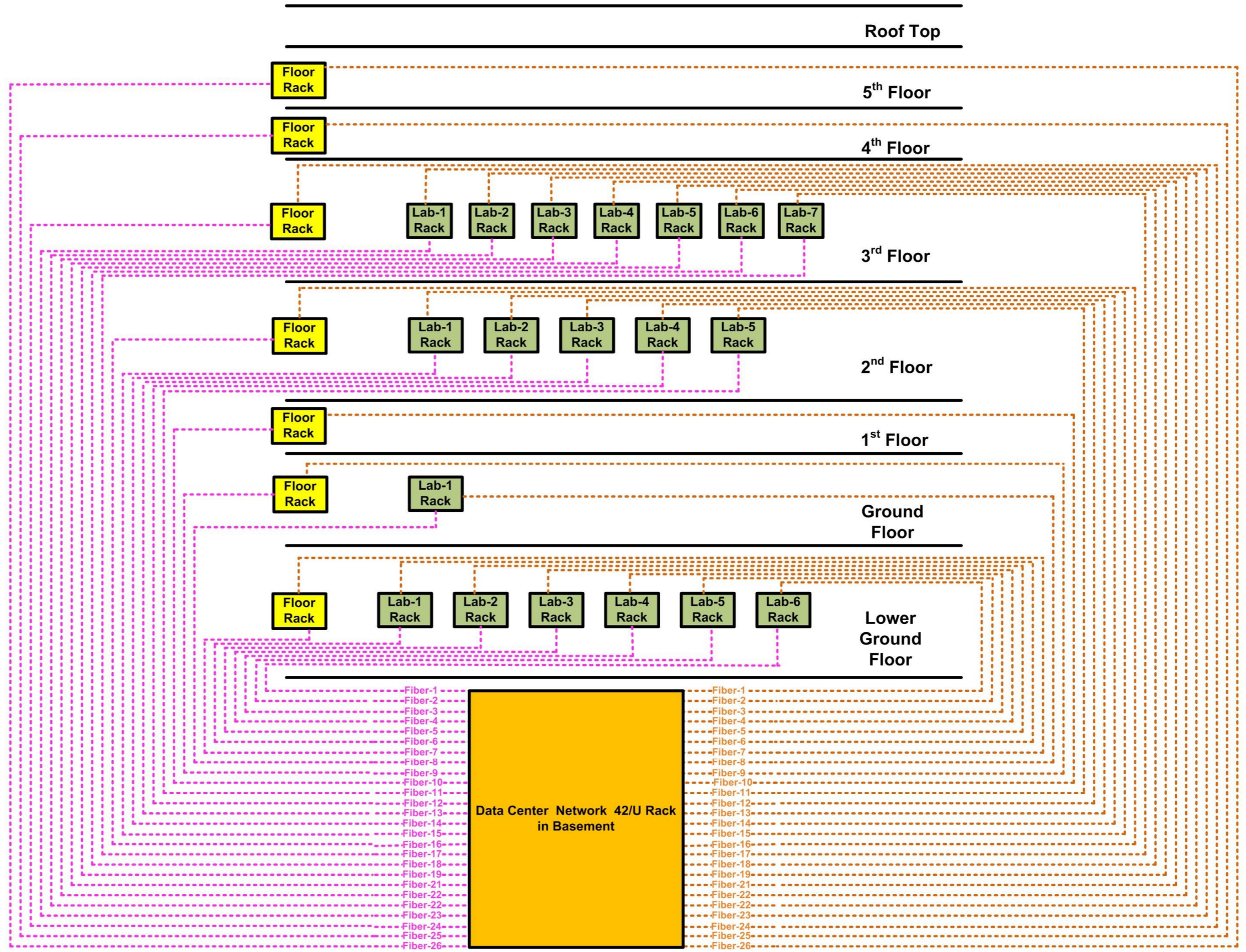

## LEGEND

Description	Symbol
12 Core Fiber Cable Primary Link	
12 Core Fiber Cable Secondary Link	
Labs Network Rack	
Floor Network Rack	
Main Network Rack	

# Fiber, Data, Telephone, Camera, Projector, Biometric Digital Signage, Wifi and TV Points Single Line Drawing

## LEGEND

Description	Symbol	Points
Dome Camera		164
Bullet Camera		54
PTZ Camera		4
Data Point		1021
Telephone Point		176
Wifi Access Point		56
TV Point		18
Biometric Point		19
Digital Signage Point		21
Projector Point		49
Cat-6 and Cat-6A Cable		7000M
12 Core Fiber Cable Primary Link		4000M
12 Core Fiber Cable Secondary Link		4000M
Labs Network 9/15/18-U Rack		19
Floor Network 42/U Rack		7
Main Network 42/U Rack		1

