



SUI NORTHERN GAS PIPELINES LTD

TENDER DOCUMENTS

**REPAIRING OF COMPUTER NUMERIC CONTROL GRINDING
MACHINE AT OVERHAUL WORKSHOP, MULTAN**

TENDER ENQUIRY NO.

TE/COMP/013/25-26

SUMMARY OF CONTENTS

<u>Subject</u>	<u>Page No</u>
(I) INVITATION FOR BIDS	03
(II) HSE STATEMENT	04
(III) FORM OF BID	10
(IV) INSTRUCTIONS TO BIDDERS & BIDDING DATA	13
(V) SCHEDULE TO BID	23
(VI) SCHEDULES-A: SCHEDULE OF PRICES	27
(VII) SCHEDULE-B: SCOPE OF WORK	28
(VIII) SCHEDULE-C: WORKS BY SUB-CONTRACTORS	34
(IX) SCHEDULE-F: INTEGRITY PACT	35
(X) CONDITIONS OF CONTRACT	36
(XI) CONTRACT DATA	47
(XII) GENERAL REQUIREMENT	48

(I)

INVITATION FOR BIDS

Date: _____

Bid Reference No.: _____

1. Sui Northern Gas Pipelines Limited (SNGPL), invites sealed bids on **single stage single envelop system** basis thru sealed envelopes & word marked with confidential from eligible firms or persons for work which will be completed in 60 days.
2. A complete set of Bidding Document is available on PPRA Website (EPADS) which may be downloaded changeby the interested bidders. Bidders are required to send Tender Processing fee of PKR 1000/- (Non-Refundable) in favor of SNGPL and shall submit the same on or before the Tender Opening date & Time.
3. All bids must be accompanied by a Bid Security amounting to PKR. 30,000/- and must be delivered to Compression Department, SNGPL Transmission office, Piran Ghaib Road, Multan. at or before 0930 hours, on 23.04.2026. Bids will be opened at 1000 hours on the same day in the presence of bidders' representatives who choose to attend, at the same address.

(II)

**HEALTH, SAFETY & ENVIRONMENT
(HSE) STATEMENT**

	SUI NORTHERN GAS PIPELINES LIMITED	DOC. # SNGPL-GPR013-F001	
		Contractor / Supplier / Vendor HSE Statement	Issue # 02

The Contractor/Supplier/Vendor shall prepare and maintain information including a clear method statement, regarding Contractor/sub-contractor activities, which outline the work to be undertaken and the method(s) for minimizing and maintaining environmental impacts, OH&S Hazards and maintaining compliance with HSE regulations.

To assist in organizing and maintaining information, background information sections have been included (section I, II, III). Sections can be modified or deleted as required when requesting a method statement from Contractors / subcontractors.

SNGPL's Personnel to Complete Sections I, II, and III
Suppliers to Complete Sections IV, V, and VI

Section I Your Information: [type or print]

Name:	
Phone Number:	
Fax Number:	
Dept Name:	

Section II. Requisition Information: [type or print]

Requisition Number:	
Project Number: (if applicable)	

Section III. Service or Activity to be Performed: [Check all that apply]

Material/Chemical: (Production/Non-production)	Paint Solvent Sealer	Treatment Chemicals Lubricants, Oils, Greases Gasoline	Janitorial Material Other (specify) _____ Other (specify) _____
Facilities/Construction:	Ditching Electrical Paint Structural	Roofing Mechanical HVAC	General Contractor Arch/Engin/Consulting Other (specify) _____
Services: (Includes Environmental Services)	Janitorial Security Maintenance	Emergency Response Env. Consulting Paint Booth Cleaning	Waste Management Other (specify) _____
Containerization:	5 gal. Or less Drums Bulk Tanks	Type of Contract:	Commodity Management On-site Manager Provided Total Cost Contract



Section IV. Supplier/Contractor/Vendor Information: [Circle / Check all that apply]

Current Supplier/Contractor/Vendor to this Facility

New Supplier/Contractor/Vendor to this Facility

Currently involved in other Facility project(s)

List Project(s): _____

(Complete Information in table below) [Type or print]

Name:	
Address:	
City & Province:	
Phone Number:	
Fax Number:	
President/General Manager/ CEO etc:	
Facility Site Coordinator:	
Email Address:	
Phone Number:	
Mobile Number:	
Fax Number:	
Pager:	
24 Hour Emergency Number:	



Subcontractor Information: (List suppliers/contractors/vendors not identified) [type or print]

Type	Firm Name
Architectural	
Mechanical	
Electrical	
Heavy Vehicles	
Industrial Services	
Painting	
Roofing	
Architectural/Engineering / Consulting Firm	
Sampling/Testing	
Chemical Supplier	
<u>Other (specify)</u>	
Scrap/Salvage Dealer	
Waste Disposal	
Demolition Disposal	

Note: It is strongly recommended that you have your subcontractors and suppliers involved at this facility should complete a separate HSE briefing package for the facility's review.

	SUI NORTHERN GAS PIPELINES LIMITED	DOC. # SNGPL-GPR013-F001	
		Issue # 02	Issue Date
Contractor / Supplier / Vendor HSE Statement		Page 4 of 5	04-02-21

Section V. Contractor / Supplier / Vendor Method Statement:

Supplier / Contractor / Vendor is financially responsible for on-site HSE remediation actions resulting from incidents involving their employees and subcontractors. To minimize the risk of environmental accidents, please review and initial the items contained in the HSE Management Basics Table below:

Health, Safety and Environment Management Basics	Tick (✓)
1. Contractor will ensure that the <ul style="list-style-type: none"> • Health of its employees is protected. • All activities carried out for the execution of the job are safe. • Compliance is met with all relevant laws and regulations. • All HSE (Health, Safety and Environment) procedures of the Company are implemented. • Safe working environment is provided to its employees. 	
2. Contractor will take all necessary steps to minimize the hazards associated with the job. Appropriate personal protective equipment should be provided to the employees where hazards exist.	
3. All incidents resulting in Dangerous Occurrence, minor or major injury, fire, vehicle accident and environmental incident are to be reported to Company within 24 hours.	
4. The contractor is to make his own arrangements for treating injuries to his employees. In the event a contractor employee is injured while working for the Company, it is the contractor's responsibility to notify the Company representative immediately and to report the circumstances of injury.	
5. Contractor's mobile equipment such as trucks, crane, welding machines etc must be maintained in good working condition. Contractor's trucks and other mobile equipment should be operated in such a way that material they are carrying does not fall off the equipment on to the roads. If repairs are required or vehicles become immobilized, arrangements must be made to correct the situation with additional outside help.	
6. Prior to the start of work a certificates from a competent authority is to be given to the site in charge by the contractor stating that all mobile heavy equipment are in good working condition. Only licensed and designated qualified people shall operate contractor's equipment.	
7. Company equipment must not be handled or tampered with by contractor. The Company representative may grant permission to the contractor on specific conditions to operate Company equipment if emergency conditions so require.	
8. When doing work involving excavation, contractors must not damage or break into or otherwise open any underground piping. Extreme care must be exercised in this respect while excavating with power driven equipment. If lines are accidentally damaged, notify the Company representative immediately.	
9. All excavation made by contractors must be fenced, barricaded or otherwise protected so as to prevent personnel from slipping or falling into them.	
10. Drawing / Excavation Include safety talk notified for facilitating contract employees ever during transportation by Cos TPT.	
11. The authorized Company executive will issue a permit appropriate for any work to be done by the contractor at Company's designated sites where work permit procedure is applicable. After receiving permit for work the contractor shall be guided by Company rules and applicable laws in performing his work.	
12. Contractors shall provide to all their staff the relevant PPE's as specified by the Company against each job. Contractors staff will do compliance.	
13. Contractor's job sites must be kept reasonably clean and free of rubbish and debris which may create tripping or fire hazard. Upon completion, the contractor shall leave the area in a clean and orderly manner, removing all contractor's debris, equipment, and excess material.	
14. Contractor shall dispose off all the waste generated from its activity in environment friendly manner as described in Pakistan Environmental Protection Act, 1997.	
15. The Contractor / Vendor / Supplier shall provide information regarding OH&S and environmental conditions pertaining to machinery / equipment / product / material / item being procured or services being hired.	

	SUI NORTHERN GAS PIPELINES LIMITED	DOC. # SNGPL-GPR013-F001	
		Issue # 02	Issue Date
Contractor HSE Statement		Page 9 of 48	04.02.2021

Section VI. Supplier/Contractor/Vendor Certification: [review and sign]

I have reviewed and understand the information contained in this document. I also understand that SNGPL's HSE Personnel have the right to inspect our activities and those of our Suppliers/Contractors/Vendors with regards to our on-site activities. I further understand that activities pertaining to service and/or maintenance contracts may only require submission of this form on an annual basis.

Name	
Title	
Signature	
Date	

HSE VIOLATION & INSURANCE:

1. The contractor shall be liable to pay compensation to his staff/ labor in case of any major injury, disability and fatality category wise as under:
 - a. In case of major injury (Injury leading to temporary disablement):
Payment of half of monthly wages till the recovery of temporary disablement or for a maximum period of one year, whichever is less.
Payment of one third of the monthly wages till the recovery of chronic ill health / disease or for a maximum period of five years, whichever is less.
 - b. In case of disability(permanent) : Rs. 500,000/-
 - c. In case of Fatality : Rs. 500,000/-

2. Failure to compliance against HSE initiative at operational sites will lead to blacklisting of contractor through following disciplinary actions.
 - a. 1st Violation : Warning letter
 - b. 2nd Violation : Deduction of Rs. 100,000/-
 - c. 3rd Violation : Deduction of Rs. 500,000/-
 - d. 4th Violation : Blacklisting

3. Contractor shall be liable to obtain 3rd party insurance to cover such incidents.

(III)

FORM OF BID

FORM OF BID

(LETTER OF OFFER)

Bid Reference No. _____

(Name of Works)

To:

The Chief Engineer (Compression)
Sui Northern Gas Pipelines Ltd.,
Transmission Office, Piran Ghaib Road,
Multan.

DEAR SIR,

1. Having examined the Bidding Documents including Instructions to Bidders, Bidding Data, Conditions of Contract, Contract Data, Specifications, Drawings, if any, Schedule of Prices and Addenda Nos. _____ for the execution of the above-named Works, we, the undersigned, being a company doing business under the name of and address _____ and being duly incorporated under the laws of Pakistan hereby offer to execute and complete such Works and remedy any defects therein in conformity with the said Documents including Addenda thereto for the Total Bid Price of Rs. _____ or such other sum as may be ascertained in accordance with the said Documents.
2. We understand that all the Schedules attached here to form part of this Bid.
3. As security for due performance of the undertakings and obligations of this Bid, we submit herewith a Bid Security in the amount of _____ drawn in your favor or made payable to you and valid for a period of twenty-eight (28) days beyond the period of validity of Bid.
4. We undertake, if our Bid is accepted, to deliver and complete the Works comprised in the Contract within the time(s) stated in Contract Data.
5. We agree to abide by this Bid for the period of _____ days from the date fixed for receiving the same and it shall remain binding upon us and may be accepted at any time before the expiration of that period.
6. Unless and until a formal Agreement is prepared and executed, this Bid, together with your written acceptance thereof, shall constitute a binding contract between us.
7. We undertake, if our Bid is accepted, to execute the Performance Security referred to in Conditions of Contract for the due performance of the Contract.
8. We understand that you are not bound to accept the lowest or any bid you may receive.

9. We do hereby declare that the Bid is made without any collusion, comparison of figures or arrangement with any other person or persons making a bid for the Works.

Dated _____

Signature _____ in the capacity of _____ duly

authorized to sign bid for and on behalf of

(Name of Bidder in Block Capitals)

(Seal)

Address

Witness:

(Signature) _____

Name: _____

Address: _____

(IV)

**INSTRUCTIONS TO BIDDERS
& BIDDING DATA**

INSTRUCTIONS TO BIDDERS

A. GENERAL

IB.1 Scope of Bid

1.1 Scope of Bid

SNGPL wishes to receive Bids for **Repairing of Computer Numeric Control Grinding Machine installed at Overhaul Workshop, Multan** (Herein after referred to as “the Works”).

The bid is being invited as per ‘Single Stage-Two Envelope’ procedure, in compliance of PPRA Rule No. 36(b). If the bidder fails to fulfill any of following mandatory requirements, his bid will be considered as non-responsive and will be rejected.

Bidders must quote for the complete scope of work. Any Bid covering partial scope of work will be rejected as non-responsive.

IB.2 Eligible Bidders

Bidding is open to all firms and persons who comply with all tender requirements mentioned under clause IB.8 of Preparation of Bids.

IB.3 Cost of Bidding

3.1 The bidder shall bear all costs associated with the preparation and submission of its bid and SNGPL will in no case be responsible or liable for those costs, regardless of the conduct or outcome of the bidding process.

B. BIDDING DOCUMENTS

IB.4 Contents of Bidding Documents

4.1 In addition to Invitation for Bids, the Bidding Documents are those stated below, and should be read in conjunction with any Addendum issued in accordance with Sub-Clause IB.6.1.

1. Instructions to Bidders & Bidding Data
2. Form of Bid
3. Schedules to Bid
 - (i) Schedule A: Schedule of Prices
 - (ii) Schedule B: Specific Works Data
 - (iii) Schedule C: Works to be Performed by Subcontractors
 - (iv) Schedule F: Integrity Pact
4. Conditions of Contract & Contract Data
5. Specifications
6. Drawings, if any.

IB.5 Clarification of Bidding Documents

5.1 A prospective bidder requiring any clarification(s) in respect of the Bidding Documents may notify SNGPL’s designated contact person / Engineer at address indicated in the Bidding Data.

5.2 The Engineer will respond to any request for clarification which it receives earlier than

Five (05) days prior to the deadline for the submission of Bids. Copies of the Engineer's response will be forwarded to all prospective bidders, who have received the Bidding Documents including a description of the enquiry but without identifying its source.

IB.6 Amendment of Bidding Documents

- 6.1 At any time prior to the deadline for submission of Bids, SNGPL may, for any reason, whether at his own initiative or in response to a clarification requested by a prospective bidder, modify the Bidding Documents by issuing addendum.
- 6.2 Any addendum thus issued shall be part of the Bidding Documents pursuant to Sub-Clause 6.1 hereof, and shall be communicated in writing to all purchasers of the Bidding Documents. Prospective bidders shall acknowledge receipt of each addendum in writing to SNGPL.
- 6.3 To afford prospective bidders reasonable time in which to take an addendum into account in preparing their Bids, SNGPL may at its discretion extend the deadline for submission of Bids.

C. PREPARATION OF BIDS

IB.7 Language of Bid

- 7.1 The bid prepared by the bidder and all correspondence and documents relating to the Bid, exchanged by the bidder and SNGPL shall be written in the English language, provided that any printed literature furnished by the bidder may be written in another language so long as accompanied by an English translation of its pertinent passages in which case, for purposes of interpretation of the Bid, the English translation shall govern.

IB.8 Documents Comprising the Bid

The bid shall comprise a single package containing the following;

- (a) Covering Letter
- (b) Form of Bid duly filled, signed and sealed, in accordance with Sub-Clause IB.14.3.
- (c) HSE contractor Statement given in tender documents, duly filled, stamped and signed by bidder.
- (d) National Tax Number (NTN) along with copy of certificate
- (e) Copy of Valid professional Tax Clearance Certificate.
- (f) Copy of Registration Certificate for Provincial Sales Tax (PST) from concerned Provincial Revenue Authority.
- (g) Following relevant paper must be provided in respective cases: -
 - Name of the bidder
 - Type of ownership i.e., Proprietor / Partnership / Private Limited Company / Public Limited Company
 - Copy of CNIC in case of single proprietor
 - Copy of partnership deed in case of partnership
 - Copy of Article of association for Private / Public Limited Companies

- (h) Technical Proposal by the bidder for the entire scope of work, along with;
 - i. Technical Literature
 - ii. Technical Compliance Sheet, duly filled and stamped by the bidder, if any
 - iii. Technical Deviation Sheet clearly mentioning any or all deviation points from the technical specification of the tender.
- (i) Schedules (A, B, C & F) to Bid duly filled and initialed, in accordance with the instructions contained therein & in accordance with Sub-Clause IB14.3.
- (j) Bid Security furnished in accordance with Clause IB.13.
- (k) Power of Attorney in accordance with Sub-Clause IB 14.5.
- (l) Documentary evidence in accordance with Clause IB.12.

IB.9 Sufficiency of Bid

- 9.1 Each bidder shall satisfy himself before Bidding as to the correctness and sufficiency of his Bid and of the rates and prices entered in the Schedule of Prices, which rates and prices shall except in so far as it is otherwise expressly provided in the Contract, coverall his obligations under the Contract and all matters and things necessary for the proper completion of the Works.
- 9.2 The bidder is advised to obtain for himself at his own cost and responsibility all information that may be necessary for preparing the bid and entering into a Contract for execution of the Works.

IB.10 Bid Prices, Currency of Bid and Payment

- 10.1 The bidder shall fill up the Schedule of Prices (Schedule A to Bid) indicating the unit rates and prices of the Works to be performed under the Contract. Prices in the Schedule of Prices shall be entered keeping in view the instructions contained in the Preamble to Schedule of Prices.
- 10.2 Unless otherwise stipulated in the Conditions of Contract, prices quoted by the bidder shall remain fixed during the bidder's performance of the Contract and not subject to variation on any account.
- 10.3 The unit rates and prices in the Schedule of Prices shall be quoted by the bidder in the currency as stipulated in Bidding Data.

IB.11 Not Used.

IB.12 Documents Establishing Works' Conformity to Bidding Documents

- 12.1 The documentary evidence of the Works' conformity to the Bidding Documents may be in the form of literature, drawings and data.
- 12.2 The bidder shall note that standards for workmanship, material and equipment, and references to brand names or catalogue numbers, if any, designated by SNGPL in the Technical Provisions are intended to be descriptive only and not restrictive.

IB.13 Bid Security

- 13.1 Each bidder shall furnish, as part of his bid, a Bid Security amounting to PKR. 30,000/- in the form of Demand Draft / Pay Order / Deposit-at-Call, issued by a Scheduled Bank in Pakistan in favor of SNGPL valid for a period up to twenty-eight (28) days beyond

- the bid validity date.
- 13.2 Any bid not accompanied by an acceptable Bid Security shall be rejected by SNGPL as non-responsive.
- 13.3 The bid securities of unsuccessful bidders will be returned upon award of contract to the successful bidder or on the expiry of validity of Bid Security whichever is earlier.
- 13.4 The Bid Security of the successful bidder will be returned after completion of all works and issuance of completion certificate.
- 13.5 The Bid Security may be forfeited:
- (a) If a bidder withdraws his bid during the period of bid validity; or
 - (b) If a bidder does not accept the correction of his Bid Price, pursuant to Sub-Clause 16.4(b) here of; or
 - (c) In the case of a successful bidder, if he fails to:
 - (i) Furnish the required Performance Security in accordance with Clause IB.21, or
 - (ii) Refuse / Fails to accept the contract award / work order in accordance with Sub-Clauses IB.20.1.

IB.14 Validity of Bids, Format, Signing and Submission of Bid

- 14.1 Bids shall remain valid for the period stipulated in the Bidding Data after the date of bid opening.
- 14.2 All Schedules to Bid are to be properly completed and signed.
- 14.3 No alteration is to be made in the Form of Bid except in filling up the blanks as directed. If any alteration be made or if these instructions be not fully complied with, the bid may be rejected.
- 14.4 Each bidder shall prepare the bid as specified in the Bidding Data of the documents comprising the bid as described in Clause IB.8 and clearly mark them
“ORIGINAL” and “COPY” as appropriate. In the event of discrepancy between them, the original shall prevail.
- 14.5 The original bid shall be typed or written in indelible ink and shall be signed by a person or persons duly authorized to sign (in the case of copies, Photostats are also acceptable). This shall be indicated by submitting a written Power of Attorney authorizing the signatory of the bidder to act for and on behalf of the bidder. All pages of the bid shall be initialed and official seal be affixed by the person or persons signing the bid.
- 14.6 The Bid shall be delivered in person or sent by registered mail / courier service at the address to SNGPL as given in Bidding Data.

D. SUBMISSION OF BID

IB.15 Deadline for Submission, Modification & Withdrawal of Bids

- 15.1 Bids must be submitted on EPADS and printed copy of the same to be submitted at the address provided in Bidding Data not later than the time and date stipulated therein.
- 15.2 Bids submitted through telegraph; telefaxes-mail shall not be considered.
- 15.3 Any bid received by SNGPL after the deadline for submission prescribed in Bidding Data will be returned unopened to such bidder.
- 15.4 Any bidder may modify or withdraw his bid after bid submission provided that the modification or written notice of withdrawal is received by SNGPL prior to the deadline for submission of bids.
- 15.5 Withdrawal of a bid during the interval between the deadline for submission of bids and the expiration of the period of bid validity specified in the Form of Bid may result in forfeiture of the Bid Security pursuant to Sub-Clause IB.13.5(a).
- 15.6 The Company is not bound to award the work to the lowest bidder and the decision of the Company in this respect shall be final and binding on all bidders.

E. BID OPENING AND EVALUATION

IB.16 Bid Opening, Clarification and Evaluation

- 16.1 SNGPL will open the bids, in the presence of bidders' representatives who choose to attend, at the time, date and location stipulated in the Bidding Data.
- 16.2 The bidder's name, Bid Prices, any discount, the presence or absence of Bid Security, and such other details as SNGPL at its discretion may consider appropriate, will be announced by SNGPL at the bid opening. Representatives of the bidders who choose to attend shall sign the attendance sheet. Any Bid Price or discount which is not read out and recorded at bid opening will not be taken into account in the evaluation of bid.
- 16.3 To assist in the examination, evaluation and comparison of Bids the Engineer / SNGPL representative may, at its discretion, ask the bidder for a clarification of its Bid. The request for clarification and the response shall be in writing and no change in the price or substance of the Bid shall be sought, offered or permitted.
- 16.4
 - (a) Prior to the detailed evaluation, pursuant to Sub-Clauses IB.16.7 to 16.8, the Engineer/SNGPL will determine the substantial responsiveness of each bid to the Bidding Documents. For purpose of these Clauses, a substantially responsive bid is one which conforms to all the terms and conditions of the Bidding Documents without material deviations. It will include to determine the requirements listed in Bidding Data.

- (b) Arithmetical errors will be rectified on the following basis:

If there is a discrepancy between the unit price and total price that is obtained by multiplying the unit price and quantity, the unit price shall prevail and the total price shall be corrected. If there is a discrepancy between the words and figures the amount in words shall prevail. If there is a discrepancy between the Total Bid price entered in Form of Bid and the total shown in Schedule of Prices-Summary, the amount stated in the Form of Bid will be corrected by SNGPL in accordance with the Corrected Schedule of Prices.

If the bidder does not accept the corrected amount of Bid, his Bid will be rejected and his Bid Security forfeited.

- 16.5 A Bid determined as substantially non-responsive will be rejected and will not subsequently be made responsive by the bidder by correction of the non-conformity.
- 16.6 Any minor informality or non-conformity or irregularity in a Bid which does not constitute a material deviation may be waived by SNGPL, provided such waiver does not prejudice or affect the relative ranking of any other bidders.
- 16.7 The Engineer/SNGPL's representative will evaluate and compare only the bids previously determined to be substantially responsive pursuant to Sub-Clauses IB.16.4 to 16.6 as per requirements given hereunder. Bids will be evaluated for complete scope of works. The prices will be compared on the basis of the Evaluated Bid Price pursuant to Sub-Clause 16.8 herein below.

(a) Technical Evaluation

It will be examined in detail whether the Works offered by the bidder complies with the Technical Provisions of the Bidding Documents. For this purpose, the bidder's data submitted with the Bid will be compared with requirements stipulated under clause IB.8 and technical specifications. Other technical information submitted with the bid regarding the Scope of Work will also be reviewed.

(b) Commercial Evaluation

It will be examined in detail whether the bids comply with the commercial/contractual conditions of the Bidding Documents. It is expected that no material deviation/stipulation shall be taken by the bidders.

16.8 Evaluated Bid Price

In evaluating the bids, the Engineer/SNGPL's representative will determine for each bid in addition to the Bid Price, the following factors (adjustments) in the manner and to the extent indicated below to determine the Evaluated Bid Price:

- (i) Making any correction for arithmetic error pursuant Sub-Clause 16.4 hereof.
- (ii) Discount, if any, offered by the bidders as also read out and recorded at the time of bid opening.

16.9 Not Used.

IB.17 Process to be Confidential

- 17.1 Subject to Sub-Clause IB.16.3 heretofore, no bidder shall contact Engineer/SNGPL's representative on any matter relating to its Bid from the time of the Bid opening to the time the bid evaluation result is announced by SNGPL. The evaluation result shall be announced at least Fifteen (15) days prior to award of Contract.
- 17.2 Any effort by a bidder to influence Engineer/SNGPL's representative in the Bid evaluation, bid comparison or Contract Award decisions may result in the rejection of his Bid. Whereas, any bidder feeling aggrieved may lodge a written complaint not later than Seven (07) days after the announcement of the bid evaluation result, however, mere fact of lodging a complaint shall not warrant suspension of procurement process.

F. AWARD OF CONTRACT

IB.18. Post Qualification

- 18.1 SNGPL, at any stage of the bid evaluation, having credible reasons for or *prima facie* evidence of any defect in supplier's or contractor's capacities, may require the suppliers or contractors to provide information concerning their professional, technical, financial, legal or managerial competence whether already pre-qualified or not:

Provided that such qualification shall only be laid down after recording reasons therefor in writing. They shall form part of the records of that bid evaluation report.

- 18.2 The determination will take into account the bidder's financial and technical capabilities. It will be based upon an examination of the documentary evidence of the bidders' qualifications submitted under Clause IB.8, as well as such other information required in the Bidding Documents.

IB.19 Award Criteria & SNGPL's Right

- 19.1 Subject to Sub-Clause IB.19.2, SNGPL will award the Contract to the bidder whose bid has been determined to be substantially responsive to the Bidding Documents and who has offered the lowest evaluated Bid Price, provided that such bidder has been determined to be qualified to satisfactorily perform the Contract in accordance with the provisions of Clause IB.18.
- 19.2 Notwithstanding Sub-Clause IB.19.1, SNGPL reserves the right to accept or reject any bid, and to annul the bidding process and reject all bids, at any time prior to award of Contract, without thereby incurring any liability to the affected bidders or any obligation to inform the affected bidders of the grounds for SNGPL's action except that the grounds for its rejection of all bids shall upon request be communicated, to any bidder who submitted a bid, without justification of the grounds. Notice of the rejection of all the bids shall be given promptly to all the bidders.

IB.20 Award of Contract

- 20.1 Prior to expiration of the period of bid validity prescribed by SNGPL, SNGPL will award the contract to the successful bidder.
- 20.2 Not Used.

IB.21 Performance Security

- 21.1 The successful bidder shall furnish to SNGPL a Performance Security in the form and the amount stipulated in the Conditions of Contract within a period of fourteen (14) days after the receipt of Letter of Acceptance / Work Order.
- 21.2 Failure of the successful bidder to comply with the requirements of Sub-Clause 21.1 or Clause IB.22 shall constitute sufficient grounds for the annulment of the award and forfeiture of the Bid Security.

IB.22 Integrity Pact

The Bidder shall sign and stamp the Form of Integrity Pact provided at Schedule-F to Bid in the Bidding Document. Failure to provide such Integrity Pact shall make the bid non- responsive.

BIDDING DATA

Instructions to Bidders

Clause Reference

1.1 **Name of Employer**

Sui Northern Gas Pipelines Limited.

Brief Description of Works

Repairing of Computer Numeric Control Grinding Machine at Overhaul Workshop, Multan

(a) Employer's address:

Compression Department, SNGPL Transmission office, Piran Ghaib Road, Multan

Tel: 061-9220342

(b) Engineer's address:

Compression Department, SNGPL Transmission office, Piran Ghaib Road, Multan

Tel: 0336-4182154

1.2 Bid shall be quoted entirely in Pak. Rupees. The payment shall be made in Pak. Rupees.

1.3 **Amount of Bid Security:**

Bid amount of PKR.30,000/- in the form of Demand Draft / Pay Order / Deposit-at-Call, issued by a Scheduled Bank in Pakistan in favor of SNGPL valid for a period up to twenty-eight (28) days beyond the bid validity date.

1.4 **Period of Bid Validity**

Bids shall remain valid for the period of 90 days after the date of bid opening.

1.5 **Number of Copies of the Bid to be submitted**

One original.

1.6 **(a) SNGPL's Address for the Purpose of Bid Submission**

Compression Department, SNGPL Transmission office, Piran Ghaib Road, Multan

Tel: 0336-4182154

1.7 **Deadline for Submission of Bids**

0930 Hours on 23.04.2026

1.8 **Venue, Time, and Date of Bid Opening**

Venue: Compression Department, SNGPL Transmission office, Piran Ghaib Road, Multan

Time: 1000 Hours

Date: 23.04.2026

(V)

SCHEDULES TO BID

SCHEDULE TO BID INCLUDE THE FOLLOWING:

- Schedule A to Bid: Schedule of Prices
- Schedule B to Bid: Scope of Work
- Schedule C to Bid: Works to be Performed by Subcontractors
- Schedule F to Bid: Integrity Pact

PREAMBLE TO SCHEDULE OF PRICES

1. General

- 1.1 The Schedule of Prices shall be read in conjunction with the Conditions of Contract, Contract Data together with the Specifications and Drawings, if any.
- 1.2 The Contract shall be for the whole of the Works as described in these Bidding Documents. Bids must be for the complete scope of works.

2. Description

- 2.1 The general directions and descriptions of works and materials are not necessarily repeated nor summarized in the Schedule of Prices. References to the relevant sections of the Bidding Documents shall be made before entering prices against each item in the Schedule of Prices.

3. Units & Abbreviations

- 3.1 Units of measurement, symbols and abbreviations expressed in the Bidding Documents shall comply with the System International Units (SI Units).

4. Rates and Prices

- 4.1 Except as otherwise expressly provided under the Conditions of Contract, the rates and amounts entered in the Schedule of Prices shall be the rates at which the Contractor shall be paid and shall be the full inclusive value of the works set forth or implied in the Contract; except for the amounts reimbursable, if any to the Contractor under the Contract.
- 4.2 Unless otherwise stipulated in the Contract Data, the rates and prices entered by the bidder shall not be subject to adjustment during the performance of the Contract.
- 4.3 All duties, taxes and other levies payable by the Contractor shall be included in the rates and prices.
- 4.4 The whole cost of complying with the provisions of the Contract shall be included in the items provided in the Schedule of Prices, and where no items are provided, the cost shall be deemed to be distributed among the rates and prices entered for the related items of the Works and no separate payment will be made for those items. The rates, prices and amounts shall be entered against each item in the Schedule of Prices. Any item against which no rate or price is entered by the bidder will not be paid for by SNGPL when executed and shall be deemed covered by the rates and prices for other items in the Schedule of Prices.
- 4.5
 - (a) The bidder shall be deemed to have obtained all information as to and all requirements related thereto which may affect the bid price.
 - (c) The Contractor shall be responsible to make complete arrangements for the mobilization and de-mobilization to the site.

4.6 The Contractor shall provide for all parts of the Works to be completed in every respect. Notwithstanding that any details, accessories, etc. required for the complete installation and satisfactory operation of the Works, are not specifically mentioned in the Specifications, such details shall be considered as included in the Contract Price.

5. Bid Prices

5.1 Break-up of Bid Prices

The various elements of Bid Prices shall be quoted as detailed by SNGPL in the format of Schedule of Prices.

The bidder shall recognize such elements of the costs which he expects to incur the performance of the Works and shall include all such costs in the rates and amounts entered in the Schedule of Prices.

5.2 Total Bid Price

The total of bid prices in the Schedule of Prices shall be entered in the Summary of Bid Prices. Bids shall be evaluated on total bid price basis.

SCHEDULE-A TO BID**SCHEDULE OF PRICES / BID SHEET****Note:**

1. All the works shall be provided constructed, complete and maintained as per drawings, conditions of contract specifications to the fully functional / operational conditions whether or not shown on the drawings including all services such as public health and sanitary works, complete in all respect.
2. The samples of all the materials should be got approved from the Site Engineer before the supply and execution works. All testing expenses shall be borne by the contractor.

Sr. No.	DESCRIPTION	UNIT	QTY.	RATE	AMOUNT
				(Rs.)	(Rs.)
1	Repairing of Computer Numeric Control Grinding Machine at Overhaul Workshop, Multan as detailed in Scope of Work	Job	01		
A	Total Amount of (Pak Rupees)				
B	PST @16%				
C	Total Amount (A+B)				

Amount in Words (_____

(VII)
SCOPE OF WORK

SCOPE OF WORK

**REPAIRING OF COMPUTER NUMERIC CONTROL
GRINDING MACHINE**

Problem statement:

Computer Numeric Control grinding machine is currently unable to maintain consistent correlation between the commanded feed and actual axis movement on both axis. Chatter / vibration is observed during movement of grinding head. Detailed inspection and rectification of fault is required. There is possibility of vibration of grinding wheel due to unbalance inertial forces and / or faulty radial and thrust bearings of grinding spindle head. Another possible reason is insufficient lubrication of grinding head / guideways due to faulty lubrication system components.

Problem Investigation / Rectification:

The guideway and mechanism of the grinding spindle as well as the guideway and mechanism of the table longitudinal feed are required to be inspected in detail after disassembly to identify abnormal wear / damage pattern. Bed and table level should be checked and corrected if needed. Using balancing arbor with flange and roller guidage, grinding wheel balance will be checked and corrected. Balancing of grinding spindle should be checked and if necessary corrected. All bearings i.e. hydrodynamic radial bearing, antifriction thrust bearing and radial roller bearing will be checked and replaced if necessary (Bearing shall be supplied by SNGPL if required). The pre-stressing force of the hydrodynamic radial bearing is educed by the spring load which will be checked and corrected if necessary. Any other malfunction / wear that may result in chatter and vibration will also be investigated e.g. v-belts and pulleys on both motor shaft and grinding spindle. Similarly, pre-stressed guideway will be inspected for any apparent wear or damage. However, it will not be intervened as it is not recommended in Manual. Coupling that transmits twisted moment and feed to grinding head must be checked for its accuracy and replaced (Coupling to be provided by SNGPL). Repairing Job executed by the Contractor shall be considered as “Completed” upon successful commissioning and verification of operating parameters up to the satisfaction of Site Engineer

For detailed know how about the machine, relevant pages from the manual are attached with this document.

1.8.6 Grinding spindle head with accessories

Illustration : Essay 1 – Fig. 13, 15

The grinding spindle head with the drive and plate under the grinding spindle wheel form a grinding unit. This unit is mounted on the rear bed plate.

In the front part of the grinding spindle head body / 1 – 13 / 1 /, a grinding spindle / 1 – 13 / 2 / with the grinding wheel and bend-wheel is mounted. The flange with the grinding wheel is covered by the wheel guard / 1 – 13 / 3 /, fixed to the grinding spindle head body. The body is from above covered by a lid. / 1 – 13 / 4 /. In the case of using the internal grinding attachment, it is replaced with the internal grinding tiltable arm (special-purpose accessories).

The grinding spindle / 1 – 13 / 2 / is on the side of the grinding wheel mounted in springy hydrodynamic radial bearing / 1 – 13 / 5 / and in antifriction thrust bearing / 1 – 13 / 6 /. On the bend-wheel side, it is mounted in radial roller bearing / 1 – 13 / 7 /.

The pre-stressing force of the hydrodynamic radial bearing is educed by the spring load / 1 – 13 / 8 /.

Fig. 1 - 13

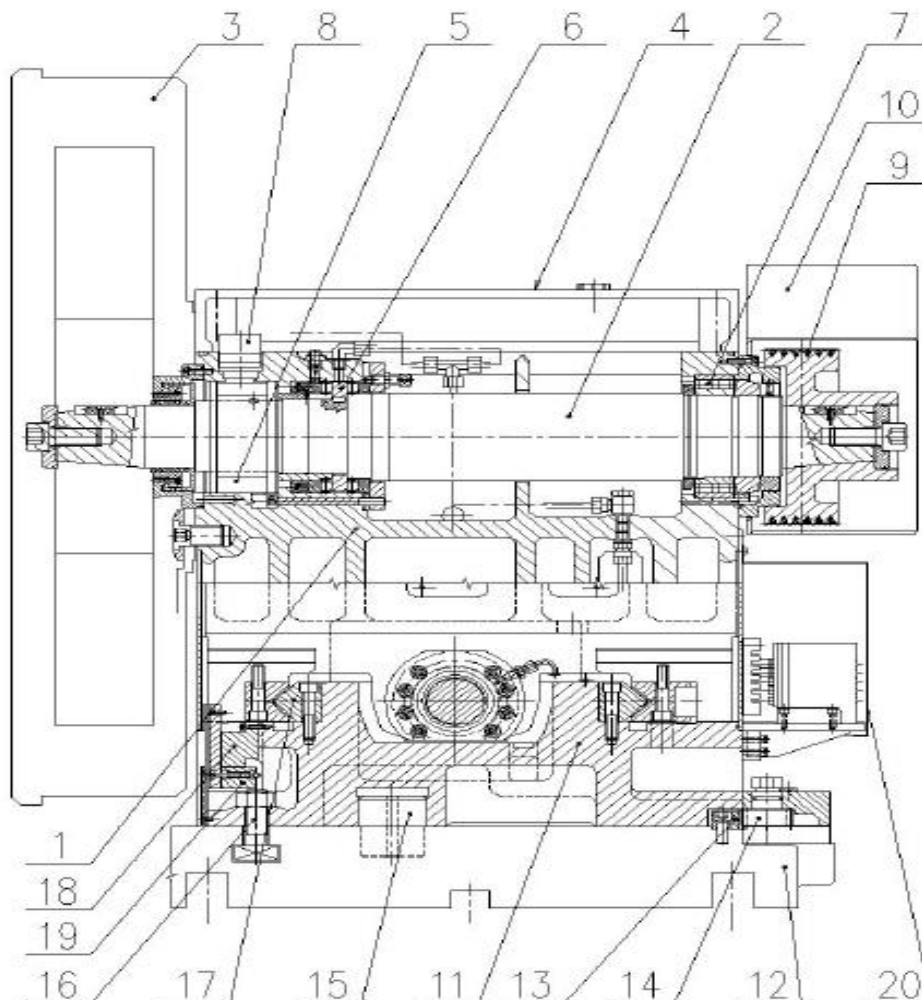

The grinding spindle bearings are lubricated hydraulically, by oil from the separated lubrication reservoir. The lubrication system is equipped with a lubrication oil flow rate indication, which in the case of insufficient flow rate turns down the grinding spindle drive.

The lifetime of bearings and the cut quality depend on correct setting of the bearings. The bearings are supplied set right from the factory. Further setting is not necessary and

manipulating the setting mechanism is non-permissible. Possible repairs and setting can be done only by professionals.

The grinding spindle drive is educed from a four-pole asynchronous electromotor / 1 – 15 / 13 /, mounted on the sliding plate / 1 – 15 / 9 /. The transmission to the spindle is provided by six V-belts / 1 – 13 / 9 /. They are covered by a safety guard / 1 – 13 / 10 /. Stretching the belts is done by sliding the motor plate by the feed screw / 1 – 15 / 10 /. The plate is then secured by three screws.

The stepless change of the motor revolutions is operated by the control system. It is reached by changing the setting of the values of the frequency converter feeding the motor.

Fig. 1 - 15

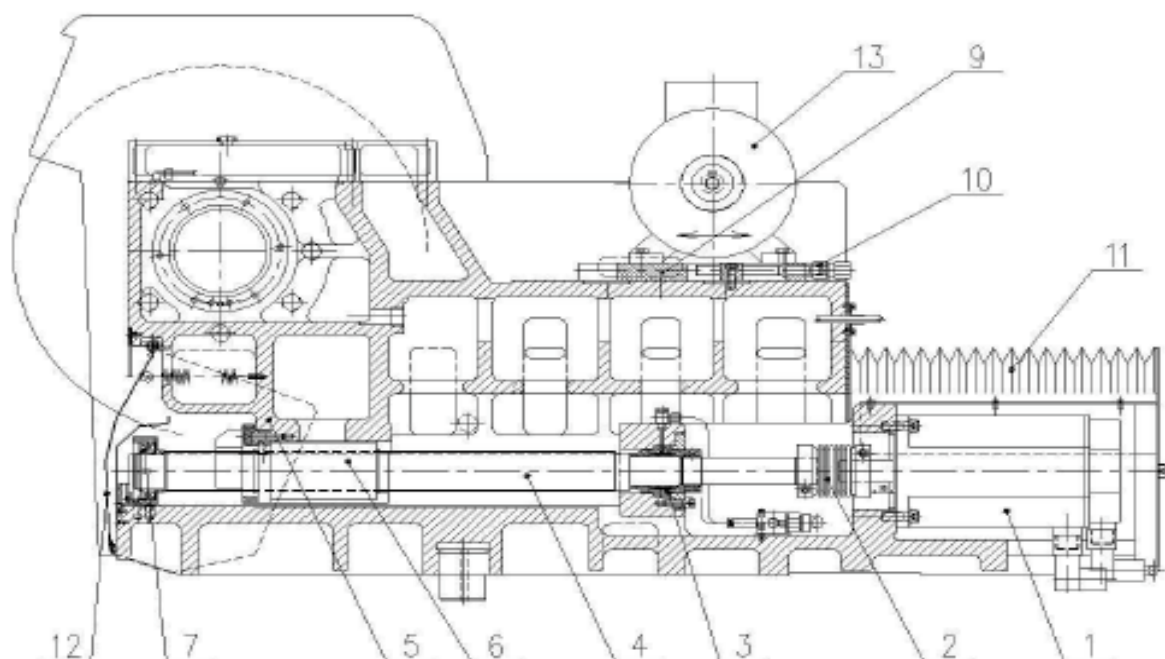

1.8.7 Plate under the grinding spindle head with infeed mechanism

Illustration : Essay 1 – Fig. 12, 13, 14, 15

The grinding spindle head / 1 – 13 / 1 /, / 1 – 12 / 1 / is mounted in antifriction, pre-stressed guideway of the plate under the grinding spindle head / 1 – 13 / 11 /, / 1 – 12 / 2 / mounted so that it allows for swivelling on the rear bed plate / 1 – 13 / 12 /, / 1 – 12 / 3 /.

The grinding spindle head swivelling property is employed in the case of using the technology of angular infeed of the grinding wheel.

The grinding unit is turned to the desired position using the pinion / 1 - 13 / 14 / on the ratchet / 1 - 13 / 13 / round the vertical pivot / 1 - 13 / 15 /.

It is fixed in the desired swivelling position by three „T“ screws with bolts / 1 - 13 / 16 / in round „T“ slots of the rear bed plate.

The fundamental part of the infeed mechanism is located in the plate under the grinding spindle head.

Fig. 1 - 12

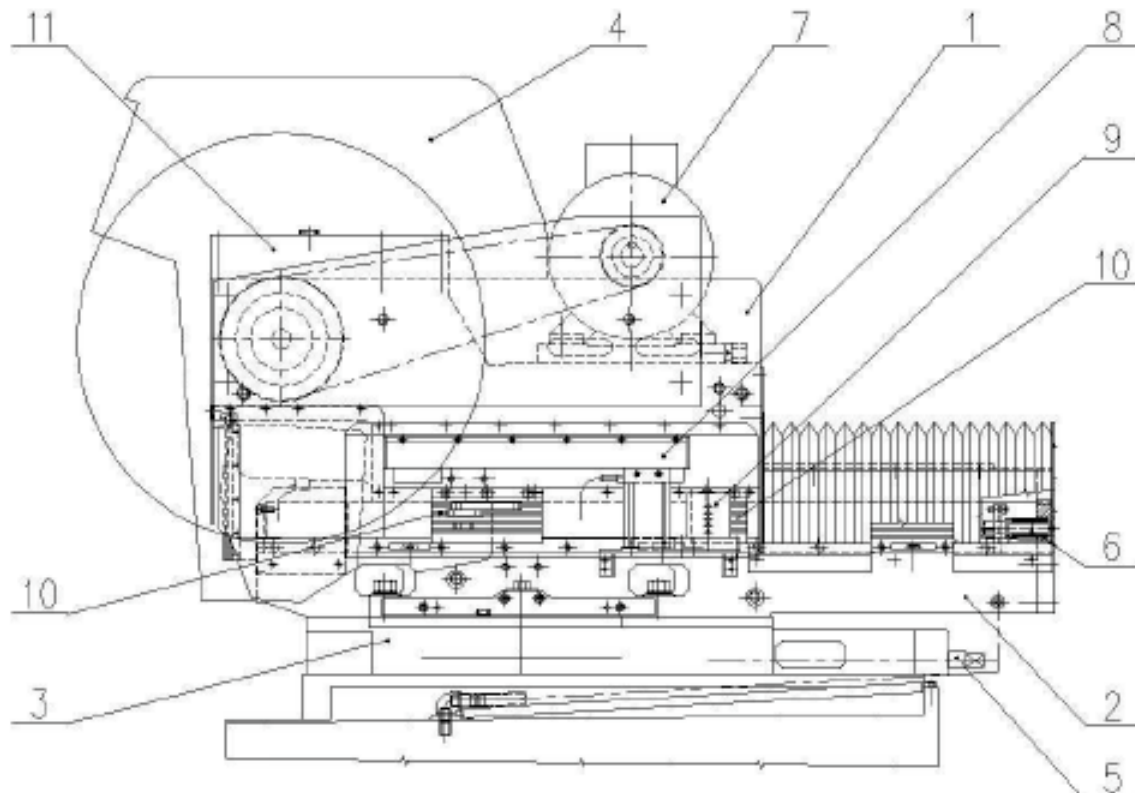

The grinding spindle head infeed is driven by electrical servomotor / 1 - 14 / 3 , / 1 - 15 / 1 /. The twisting moment is transmitted over the wave guide junction / 1 - 14 / 4 , / 1 - 15 / 2 / to the ball screw / 1 - 14 / 1 , / 1 - 15 / 4 / mounted in the radial thrust bearing / 1 - 14 / 2 , / 1 - 15 / 3 / and in the bearing / 1 - 15 / 7 /.

A pre-stressed ball bolt moves along the screw / 1 - 14 / 5 , / 1 - 15 / 6 / , which is fastened by its flange by screws in the bottom surface of the saddle / 1 - 15 / 5 / and thus transmits the transverse feed to the grinding spindle head.

The grinding spindle head is mounted in the antifriction guideway / 1 - 13 / 17 /. Rollers move in hardened guide bars of the profile VM. The guidage is pre-stressed by the pre-stressing wedge. It comes set from the manufacturer and it is not recommendable to intervene.

The guidage is protected against coolant splash and impurities from grinding by side guards, rear covering bellow / 1 - 15 / 11 / and by the front tilting guard / 1 - 15 / 12 /.

The grinding spindle head guideway as well as the ball screw and its bolt mountings are lubricated by oil from the lubricating aggregate.

Under the motor plate / 1 – 15 / 9 /, a mounting hole is covered. It provides for an access to the space inside the plate under the grinding spindle head round the ball screw / 1 – 15 / 3 / and the servomotor clutch / 1 – 15 / 2 /.

The grinding spindle head position in the infeed track is measured indirectly using a generator of pulses in the motor centre line. The machine in other design is equipped with direct measuring, using a linear switch of position, HEIDENHAIN LS 186 C / 1 – 13 / 18 / placed under the left guideway of the grinding spindle head. The position-indicating "runner" / 1 - 13 / 19 / is mounted under the sensor ruler. End-position switches positioned on the console on the right side of the grinding spindle head under the guard / 1 – 13 / 20 / are switched on by adjustable stops / 1 – 12 / 10 / upon reaching the respective end positions by the grinding spindle head. Stops are set by the manufacturer and it is not permitted to change their values. Having been adjusted by the manufacturer, the whole reversing system has been enclosed.

Fig. 1 - 14

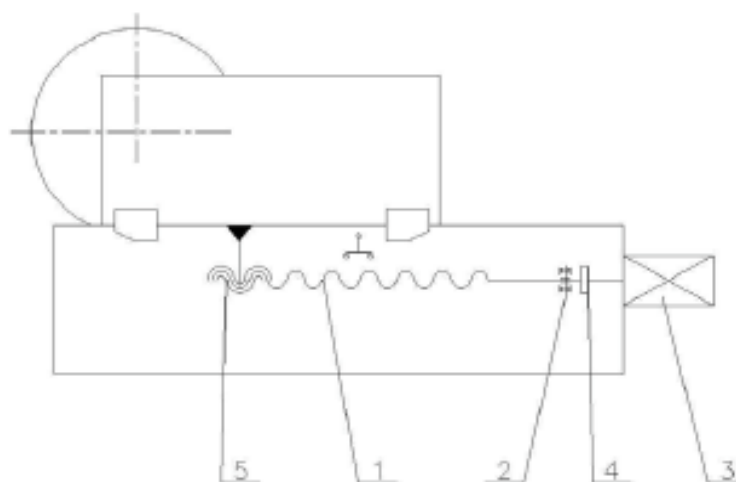

Each ball screw bolt position is successively determined by program / software / stop, electrical / hardware / stop, and end positions are secured by a mechanical reversing system, which is realized by a complex of hydraulic shock-absorbers at the ends of guideway / 1 – 12 / 6 /.

Having been adjusted by the manufacturer, the whole reversing system has been enclosed / 1 – 15 / 11 /.

WORKS TO BE PERFORMED BY SUBCONTRACTORS

The bidder will do the work with his own forces except the work listed below which he intends to sub-contract.

Sr. #	Items of Works to be Sub-Contracted	Name and address of Sub-Contractors	Statement of similar works previously executed (attach evidence)

Note:

1. No change of Sub-Contractors shall be made by the bidder without prior approval of SNGPL.
2. The truthfulness and accuracy of the statement as to the experience of Sub-Contractors is guaranteed by the bidder. SNGPL’s judgment shall be final as to the evaluation of the experience of Sub-Contractors submitted by the bidder.
3. Statement of similar works shall include description, location & value of works, year completed and name & address of the clients.

SCHEDULE-F TO BID

(INTEGRITY PACT)

DECLARATION OF FEES, COMMISSION AND BROKERAGE ETC. PAYABLE BY THE SUPPLIERS OF GOODS, SERVICES & WORKS IN CONTRACTS WORTH RS. 10.00 MILLION OR MORE

Contract No. _____ Dated _____ Contract Value:

Contract Title: _____

_____ [name of Supplier] hereby declares that it has not obtained or induced the procurement of any contract, right, interest, privilege or other obligation or benefit from Government of Pakistan (GoP) or any administrative subdivision or agency thereof or any other entity owned or controlled by GoP through any corrupt business practice.

Without limiting the generality of the foregoing, [name of Supplier] represents and warrants that it has fully declared the brokerage, commission, fees etc. paid or payable to anyone and not given or agreed to give and shall not give or agree to give to anyone within or outside Pakistan either directly or indirectly through any natural or juridical person, including its affiliate, agent, associate, broker, consultant, director, promoter, shareholder, sponsor or subsidiary, any commission, gratification, bribe, finder's fee or kickback, whether described as consultation fee or otherwise, with the object of obtaining or inducing the procurement of a contract, right, interest, privilege or other obligation or benefit in whatsoever form from GoP, except that which has been expressly declared pursuant hereto.

_____ [name of Supplier] certifies that it has made and will make full disclosure of all agreements and arrangements with all persons in respect of or related to the transaction with GoP and has not taken any action or will not take any action to circumvent the above declaration, representation or warranty.

_____ [name of Supplier] accepts full responsibility and strict liability for making any false declaration, not making full disclosure, misrepresenting facts or taking any action likely to defeat the purpose of this declaration, representation and warranty. It agrees that any contract, right, interest, privilege or other obligation or benefit obtained or procured as aforesaid shall, without prejudice to any other rights and remedies available to GoP under any law, contractor other instrument, be voidable at the option of GoP.

Notwithstanding any rights and remedies exercised by GoP in this regard, [name of Supplier] agrees to indemnify GoP for any loss or damage incurred by it on account of its corrupt business practices and further pay compensation to GoP in an amount equivalent to ten times the sum of any commission, gratification, bribe, finder's fee or kickback given by [name of Supplier] as aforesaid for the purpose of obtaining or inducing the procurement of any contract, right, interest, privilege or other obligation or benefit in whatsoever form from GoP.

(X)

CONDITIONS OF CONTRACT

CONDITIONS OF CONTRACT

1. GENERAL PROVISIONS

1.1 Definitions

In the Contract as defined below, the words and expressions defined shall have the following meanings assigned to them, except where the context requires otherwise:

The Contract

1.1.1 “Contract” means the Contract or Work Order issued as a result of bidding process to the successful bidder.

1.1.2 “Specifications” means the document as listed in the Contract Data, including SNGPL’s requirements in respect of design to be carried out by the Contractor (if any), and any Variation to such document.

1.1.3 “Drawings” means SNGPL’s drawings of the Works as listed in the Contract Data, and any Variation to such drawings.

1.1.4 Not Used

1.1.5 Not Used

1.1.6 “Party” means either the Employer or the Contractor.

1.1.7 Not used

1.1.8 Not Used

1.1.9 “Time for Completion” means the time for completing the Works as stated in the Contract Data, calculated from the Commencement Date.

1.2 **Not Used**

1.3 **Not Used**

1.4 **Law**

The law of the Contract is the relevant Law of Islamic Republic of Pakistan.

1.5 **Communications**

All Communications related to the Contract shall be in English language.

1.6 **Statutory Obligations**

The Contractor shall comply with the Laws of Islamic Republic of Pakistan and shall give all notices and pay all fees and other charges in respect of the Works.

2. **The Company**

2.1 Provision of Site

SNGPL shall provide the Site and right of access there to at the times stated in the Contract Data.

2.2 Not Used

2.3 SNGPL's Instructions

The Contractor shall comply with all instructions given by SNGPL's representative / Engineer, if notified by SNGPL, in respect of the Works including the suspension of all or part of the Works.

2.4 Not Used

3. SNGPL'S REPRESENTATIVES

3.1 Authorized Person

SNGPL shall appoint a duly authorized person to act for him and on his behalf for the purposes of this Contract. Such authorized person shall be duly identified in the Contract Data or otherwise notified in writing to the Contractor as soon as he is so appointed.

3.2 Not Used

4. THE CONTRACTOR

4.1 General Obligations

The Contractor shall carry out the Works properly and in accordance with the Contract. The Contractor shall provide all supervision, labor, Materials, Contractor's Equipment which may be required.

4.2 Contractor's Representative

The Contractor shall appoint a representative at site on full time basis to supervise the execution of work and to receive instructions on behalf of the Contractor but only after obtaining the consent of SNGPL for such appointment which consent shall not be unreasonable withheld by SNGPL. Such authorized representative may be substituted/replaced by the Contractor at any time during the Contract Period but only after obtaining the consent of SNGPL as aforesaid.

4.3 Subcontracting

The Contractor shall not subcontract the whole of the Works. The Contractor shall not sub contract any part of the Works without the consent of SNGPL.

4.4 Performance Security

Performance Security is applicable as stipulated in the Contract Data.

5. DESIGN BY CONTRACTOR

5.1 Contractor's Design

The Contractor shall carry out design to the extent specified, if referred to in the Contract Data. The Contractor shall promptly submit to the Engineer/SNGPL all designs prepared by him. Within fourteen (14) days of receipt the Engineer/SNGPL shall notify any comments or, if the design submitted is not in accordance with the Contract, shall reject it stating the reasons. The Contractor shall not construct any element of the Works designed by him within fourteen (14) days after the design has been submitted to the Engineer/SNGPL or which has been rejected. Design that has been rejected shall be promptly amended and resubmitted. The Contractor shall resubmit all designs commented on taking these comments into account as necessary.

5.2 Responsibility for Design

The Contractor shall remain responsible for his bided design and the design under this Clause, both of which shall be fit for the intended purposes defined in the Contract and he shall also remain responsible for any infringement of any patent or copyright in respect of the same. The Engineer/SNGPL shall be responsible for the Specifications and Drawings.

5.3 Not Used.

6. Not Used

7. TIME FOR COMPLETION

7.1 Execution of the Works

The Contractor after taking over the site shall proceed expeditiously and without delay and shall complete the Works, subject to Sub-Clause 7.3 below, within the Time for Completion.

7.2 Not Used

7.3 Extension of Time

If by reason of the amount of extra or additional work of any kind or any cause of delay referred to in these conditions, or exceptional adverse climate conditions, or other special circumstances of any kind whatsoever which may occur, other than through a default of the Contractor, the company shall entitle the Contractor to an extension of time for the completion of the works. The Company shall determine the amount of such extension and shall notify the Contractor accordingly. Provided that the Company is not bound to take into account any extra or additional work or other special circumstances unless the contractor has within Fifteen days after such work has been commenced or such circumstances have arisen, or as soon thereafter as in practicable, submitted to the Company's representative full and detailed particulars of any extension of time to which he may consider himself entitled in order that such submission may be investigated at the time.

7.4 Liquidated Damages for Delay

If the Contractor shall fail to achieve completion of the works within the time prescribed in Contract Data hereof, then the Contractor shall pay to the company

the sum stated in the Contract Data as liquidated damages for such default. The Company may, without prejudice to any other method of recovery, deduct the amount of such damages from any monies in his hands, due or which may become due to the Contractor. The payment or deduction of such damages shall not relieve the Contractor from his obligation to complete the works, or from any other of his obligations and liabilities under the Contract.

7.5 **Reduction of Liquidated Damages**

If, before the completion of the whole of the work or any part or section of the work has been certified by the Company as completed, and occupied or used by the company, the liquidated damages for delay shall, for any period of delay after such certificate and in the absence of alternative provisions in the contract be reduced in the proportion which the value of the part of section so certified bears to the value of the whole of the works.

If the Contractor fails to achieve completion of the work within the stipulated period stated in Contract Data, besides imposing the Liquidated Damages clause & on expiry of finishing target date, the company without prejudice, will issue a final notice for completion of the job and after the expiry period 14 (Fourteen) days, the company will take over the Project from the defaulter Contractor. The company shall be entitled to complete the remaining works on the risk and cost of the said Contractor.

8. **TAKING-OVER**

8.1 **Completion**

The Contractor shall notify the completion of Works to Engineer/SNGPL's representative.

8.2 **Taking-Over Notice**

Within fourteen (14) days of the receipt of the said notice of completion from the Contractor, SNGPL/Engineer shall either takeover the completed Works and issue a Certificate of Completion to that effect or shall notify the Contractor his reasons for not taking-over the Works. While issuing the Certificate of Completion as aforesaid, SNGPL/Engineer may identify any outstanding items of work which the Contractor shall undertake during the Maintenance Period.

9. **Definition of Period of Maintenance**

9.1 In these conditions, the expression "period of maintenance" shall mean the period of maintenance named in the Contract Data, calculated from the date of completion of the works, certified by the Company.

9.2 **Maintenance Certificate**

The Contract shall not be considered as completed until a maintenance certificate shall have been signed by the Company and delivered to the contractor stating that the works have been completed and maintained to its satisfaction. The maintenance certificate shall be given by the Company within twenty-eight days after the expiration of the period of maintenance or as soon thereafter as any works ordered during period, shall have been completed to the satisfaction of the Company and full effect shall be given to this clause notwithstanding any previous entry on the works or the taking possession,

working or using thereof or any part thereof by the Company. Maintenance period shall be as stated in Contract Data after completion of work.

9.3 Execution of Work of Repair Etc.

To the intent that the works shall at or as soon as practicable after the expiration of the period of maintenance be delivered to the company in the condition required by the contract, fair wear and tear excepted, to the satisfaction of the Company, the contractor shall finish the work, if any, outstanding at the date of completion, as certified hereof, as soon as practicable after such date and shall execute all such repair , amendment, reconstruction, rectification and making good defects, imperfections, shrinkages or other faults as may be required of the contractor in writing by the company during the period of maintenance, or within 14 days after its expiration, as a result of an inspection made by or on behalf of the company prior to its expiration.

9.4 Cost of Execution of Repair work etc.

All such works shall be carried out by the contractor at his own expense if the necessity thereof shall, in the opinion of the Company, be due to the use of materials or workmanship not in accordance with the contract, or to neglect or failure on the part of the contractor to comply with any obligation, expressed or implied, on the contractor's part under the contract. If, in the opinion of the Company, such necessity shall be due to any other cause, the value of such work shall be ascertained and paid for as if it were additional work.

9.5 Remedy on Contractor's failure to carry out Work required

If the contractor shall fail to do any such work as aforesaid required by the Company, the company shall be entitled to employ and pay other persons to carry out the same and if such work is the work, which in the opinion of the Company, the contractor was liable to do at his own expense under the contract, then all expenses consequent thereon or incidental thereto shall be recoverable from the contractor by the company, or may be deducted by the company from any money due or which may become due to the contractor.

10. VARIATIONS AND CLAIMS

10.1 Right to Vary

- i) The Company shall make any variation of the form, quality or quantity of the works in Bid Sheet or any part thereof that may, in its opinion, be necessary and for that purpose, or if for any other reason it shall, in its opinion be desirable, the company shall have power to order the contractor to do and the contractor shall do any of the following;
 - a. Increase or decrease the quantity of any work included in the contract.
 - b. Omit any such work
 - c. Change the character or quality or kind of any such work
 - d. Change the levels, lines, position and dimensions of any part of the works
 - e. Execute additional work of any kind necessary for the completion of works

And no such variation shall in any way vitiate or invalidate the contract, but the value, if any, of all such variations shall be taken into account in ascertaining the amount of the contract price.

10.2 **Valuation of Variations**

All extra or additional work done or work omitted by the order of the Company shall be valued at the rates and prices set out in the contract if, in opinion of the Company, the same shall be applicable.

For items included in the Bid Sheet, Specific Specifications, Rate Analysis may be desired from the Contractor by the Company to justify his rates. These rates analysis will be rationalized/corrected by the Company and the valuation of extra work will be made on the basis of rates corrected/rationalized/approved by the Company.

10.3 **Early Warning**

The Contractor shall notify the Engineer/SNGPL in writing as soon as he is aware of any circumstance which may delay or disrupt the Works, or which may give rise to a claim for additional payment.

To the extent of the Contractor's failure to notify, which results to the Engineer/SNGPL being unable to keep all relevant records or not taking steps to minimize any delay, disruption, or Cost, or the value of any Variation, the Contractor's entitlement to extension of the Time for Completion or additional payment shall be reduced/rejected.

10.4 **Not used**

10.5 **Variation and Claim Procedure**

No such variations shall be made by the Contractor without an order in writing of the Company. Provided that no order in writing shall be required for increase or decrease in quantity of any work where such increase or decrease is not the result of an order given under this clause but is the result of the quantities exceeding or being less than those stated in the Bid sheet. Provided also that if for any reason the Company shall consider it desirable to give any such order verbally, the contractor shall comply with such order and any confirmation in writing of such verbal order given by the Company, whether before or after the carrying out of the order, shall be deemed to be an order in writing within the meaning of this Clause. Provided further that if the contractor shall within Seven days confirm in writing to the Company and such confirmation shall not be contradicted in writing within Fourteen days by the Company, it shall be deemed to be an order in writing by the Company.

11. CONTRACT PRICE AND PAYMENT

11.1 Unless otherwise provided, Payments shall be made to the Contractor strictly in accordance with the Contract Data and in the manner given hereunder.

11.2 The contractor shall submit to the Company his bill and/or claims which the Company, after necessary checking/scrutiny, adjustments and deductions, shall within 45(Forty-Five) working days of the receipt of such bill shall pay to the contractor the certified amount.

11.3 The amount(s) of Retention Money, (security deposit) Mobilization Advance, Secured Advance and/or any other amount(s) which are due or which may become

due from the Contractor shall be deducted from each payment at the rate as specified in the Contract Data.

11.4 If the Works or part of the Works contained in the claims of the Contractor are found incomplete, defective, condemned, rejected and/or with calculation error(s) etc., the Company shall and/or can:

- a) Correct and deduct from the bill such amount or amounts as the Company may consider proper and reasonable – or
- b) Withhold payment certificate till the proper completion and rectification of the Works or part(s) thereof - or
- c) Return back the said bill to the Contractor for re-submission of proper bill in proper form and details as required by the Company.

The Contractor shall have no claim whatsoever for any delay thus occurring in issuing the payment certificate and releasing the payment thereof.

11.5 **Retention**

- a) The amount of Retention money shall be deducted from final payment certificate as mentioned in section XI i.e., Contract Data.
- b) All sums payable by the Contractor to the Company under the terms of this Contract may be deducted from the security deposits, and in the event of retention money being reduced due to such deductions, the Contractor shall within ten days thereafter make good in cash the deficiency so caused.
- c) The amount of retention money shall, after making all deductions for sums recoverable under this Contract be refunded to the Contractor after successful completion of the maintenance period as described in clause 9 above.

11.6 **Currency**

Payment shall be in the PAK Rupees.

12. **DEFAULT**

12.1 **Default by Contractor**

If the Contractor abandons the Works, refuses or fails to comply with a valid instruction of the Engineer/SNGPL or fails to proceed expeditiously and without

delay, or is, despite a written complaint, in breach of the Contract, SNGPL may give notice referring to this Sub-Clause and stating the default.

If the Contractor has not taken all practicable steps to remedy the default within fourteen (14) days after receipt of SNGPL's notice, SNGPL may by a second notice given within a further twenty-one (21) days, terminate the Contract. The Contractor shall then demobilize from the Site leaving behind any Contractor's Equipment which SNGPL instructs, in the second notice, to be used for the completion of the Works at the risk and cost of the Contractor.

In case of default on the part of the contractor in carrying out such order, the company shall be entitled to employ and pay other persons to carry out the same and all expenses consequent thereon or incidental thereto shall be recoverable from the contractor by the company, or may be deducted by the company from any money due or which may become due to the contractor.

12.2 **Not Used**

12.3 **Not Used**

12.4 **Not Used**

13. RISKS AND RESPONSIBILITIES

13.1 Way Leaves etc.

The Contractor shall bear all costs and charges for special or temporary way leaves required by him in connection with access to the site. The contractor shall also provide at his own cost any additional accommodation outside the site required by him for the purposes of the works.

13.2 Rate of Progress

If for any reason, which does not entitle the Contractor to an extension of time, the rate of progress of the works or any section is at any time, in the opinion of the Company, too slow to ensure completion by the prescribed time or extended time for completion, the Company shall so notify the Contractor in writing and Contractor shall thereupon take such steps as are necessary and the Company may approve to expedite progress so as to complete the works or such section by the prescribed time or extended time. The contractor shall not be entitled to any additional payment for taking such steps. If, as a result of any notice given by the Company under this Clause, the Contractor shall seek the Company's permission to do any work at night or on SUNDAY / FRIDAY as applicable, if locally recognized as days of rest, or their locally recognized equivalent, such permission shall not be unreasonably refused.

13.3 Contractor's Plant & Equipment

- i) All constructional plant, temporary works, and materials provided by the contractor shall, when brought on the site, be deemed to be exclusively intended for the execution of the works and the contractor shall not remove the same or any part thereof, except for the purpose of moving it from one part of the site to another, without the consent, in writing, of the Company, which shall not be unreasonably withheld.
- ii) Upon completion of the works, the contractor shall remove from the site all the said constructional plant and temporary works remaining thereon and any unused materials provided by the contractor.
- iii) The Company shall not at any time be liable for the loss of or damage to any of the said constructional plant, temporary works or materials.

13.4 Contractor's Employees

The contractor shall ensure to deploy experienced and qualified staff at SNGPL's site for execution of works, along with supervisory staff. SNGPL shall be at liberty to object to and require the Contractor to remove forthwith from the works any person employed by the Contractor in or about the construction, completion and maintenance of the works, who, in the opinion of the Company, misconducts himself, or is incompetent or negligent in the proper performance of his duties, or whose employment is otherwise considered by the Company to be undesirable and such person shall not be again employed upon the works without the written permission of the Company. Any person so removed from the works shall be replaced as soon as possible by a competent substitute approved by the Company.

13.5 Clearance of Site on Completion

On the completion of the works the contractor shall clear away and remove from the site all constructional plant, surplus materials, rubbish and temporary works of every kind, and leave the whole of the site and works clean and in a workmanlike condition to the satisfaction of the Company.

13.6 Removal of Improper work & Material

The Company shall during the progress of the works have power to order in writing from time to time: -

- a. The removal from the site, within such time or times as may be specified in the order, of any materials, which, in the opinion of the Company, are not in accordance with the contract
- b. The substitution of improper and unsuitable Materials
- c. The removal and proper re-execution, notwithstanding any previous test thereof or interim payment therefore, of any work which in respect of materials or workmanship is not in the opinion of the company Project Manager, in accordance with the contract.

13.7 Force Majeure

If Force Majeure occurs, the Contractor shall notify the Engineer/SNGPL immediately. If necessary, the Contractor may suspend the execution of the Works and, to the extent agreed with SNGPL demobilize the Contractor's Equipment.

14. Not Used

15. Not Used

16. INTEGRITY PACT

If the Contractor, or any of his Sub-Contractors, agents or servants is found to have violated or involved in violation of the Integrity Pact signed by the Contractor as Schedule-F to his Bid, then SNGPL shall be entitled to:

- (a) Recover from the Contractor an amount equivalent to ten times the sum of any commission, gratification, bribe, finder's fee or kickback given by the

Contractor or any of his Sub-Contractors, agents or servants;

(b) Terminate the Contract; and

(c) Recover from the Contractor any loss or damage to SNGPL as a result of such termination or of any other corrupt business practices of the Contractor or any of his Sub-Contractors, agents or servants.

On termination of the Contract under Sub-Para (b) of this Sub-Clause, the Contractor shall demobilize from the Site leaving behind Contractor's Equipment which SNGPL instructs, in the termination notice, to be used for the completion of the Works at the risk and cost of the Contractor.

(XI) CONTRACT DATA

Sub-Clauses of Conditions of Contract

1.1.3	SNGPL's Drawings, if any	N/A
1.1.9	Time for Completion	60 Days after Provision of site.
2.1	Provision of Site	14 days after receipt of Work Order
3.1	Authorized Person	Mr. M. Abubakar Sharif, (0336-4182154)
4.4	Performance Security	10 % of total Contract / Work order value in Pak Rupees in the form of bank guarantee / CDR / Banker's Cheque as performance bond to be submitted within 14 days after the receipt of Contract. Performance bond shall be released after successful completion ad commissioning of job.
5.1	Requirements for Contractor's design (if any)	Refer to Scope of work and Technical Specification
7.4	Amount of Liquidated Damages	0.10% of the final cost of project per day for each day of delay.
7.4	Limit of Liquidated Damages	Ten percent 10% of final cost of the project.
9.2	Maintenance Period	Maintenance period shall be 06 months after completion of work.
11.2	Terms of Payments	Forty-Five (45) working days after submission of completion certificate and approved invoice(s). No advance and / or partial payment shall be made.
11.5	Percentage of retention	10% of total amount to be retained until satisfactory completion of maintenance period
14.1	Bid Validity	90 days after the bid opening date

(XII)
GENERAL REQUIREMENT:

1. Bidders may visit the SNGPL site for complete understanding of scope of work
2. The Bidder shall also nominate a 'Contact Person' who shall be responsible for overall work performance.
3. Bidder to furnish copy of valid Professional Tax, NTN & PRA, GST & PEC Certificates.
4. Financial proposal shall be prepared in Pak Rupees.
5. A comprehensive and firm commercial proposal should be submitted as per bid sheet form.
6. No Conditional Tender or terms & Conditions other than mentioned in tender documents shall be applicable.
7. All pages of the bid proposal shall be signed and stamped by bidder or his authorized representatives. Authorization shall be furnished in the form of valid, written and irrevocable power of attorney, which shall accompany the bid.
8. Bid Evaluation criteria shall be based on specification / Scope of Work