

RESTRICTED

REGISTERED / IMMEDIATE

Central Avn Spares Depot (EME)
Dhamial Camp Rawalpindi
Telephone: 8018 - 35580
81201-EME / LP /25-26 / IT-18
10 Mar 2026

To: Mr. Rizwan Mehmood,
(Assistant Director - II)
Public Procurement Regulatory Authority
1st Floor FBC Building near State Bank,
Sector G-5/2, Islamabad

Subject: **Local Purchase of Aviation Stores**

Central Aviation Spares Depot (EME) Invitation Tenders no 81201-EME/LP/25-26/
IT-18/PPRA dated 10 Mar 2025 (**copy attached**) may be uploaded on PPRA for procurement of
stores, please.

Maj
OIC LP Branch
(Muhammad Zubair)

RESTRICTED

CENTRAL AVIATION SPARES DEPOT (EME)
QASIM ARMY AVIATION BASE, DHAMIAL CAMP RAWALPINDI
TENDER NOTICE

1. Sealed tender is invited from reputed firms possessing NTN certificates for supply of under mentioned items. Procurement will be carried out in the light of PPRA rules. **Quantity mentioned in tender is approximate requirement for complete financial year, however purchase quantity can be increased or decreased.** Being shelf life items purchase order will be placed in batches / packages in reduced quantity as per immediate requirements / needs. Firms should avoid quoting exorbitant rates.

Ser	Tender No	Detail of Required Stores	No of Items	Delivery Period	Date and Time of Tender	
					Submission	Opening
a.	81201-EME/LP/25-26/IT-18 dated 10 Mar 2026	Misc & Cap Bldg	(List attached as Annexure A to D	30 Days Local Stores & 90 Days For Foreign Stores	30 Mar 2026 at 1030 Hrs	30 Mar 2026 at 1100 Hrs

2. **Submission of Offers by the Firms.**

- a. Quoted rates must be valid up to **30 Jun 2026**.
- b. Delivery Period should be 1 x month for local and 3 x months for imported items.
- c. Those firms which are having pending deliveries of last financial year will not be allowed to participate in tender.
- d. **Bids of registered firms having valid MI-Dte security clearance will only be accepted.**
- e. Firm must quote items in separate envelopes clearly marked "Technical Offer" and Commercial Offer" in separate categories Anx wise as given below. **IT number must be mentioned on both envelopes: -**

Category	Heading on Envelop (Technical)	Heading on Envelop (commercial)
Misc	Annexure A,B,C &D (Technical)	Annexure A,B,C &D (Commercial)

- f. **Technical Offer.** The offer must include the following information which will be evaluated by a board:-
 - (1) Brand name, specification, country of origin.
 - (2) The source / firm authorization for all branded items to be imported by the firms. The firms are also requested to provide authorization / license to import these items.
 - (3) Validity of offer should be upto **30 Jun 2026**.
 - (4) Delivery period for each item must be mentioned on the quote. Delivery period will start from the date of issuance of POs, if firm considers that delivery will not be possible within 1 x month for local and 3 x months for foreign items. Firm should approach this office before expiry of delivery period.
 - (5) The purchaser can waive off any of the conditions stipulated in this tender inquiry and reserve the right to accept or reject thereto.
 - (6) Bidders should note that decision of Commandant CASD (EME), Dhamial Camp, Rawalpindi will be final in respect of acceptance / rejection of the offers.
 - (7) All samples and supplies will be subject to tests and inspections either by the board of officers constituted for the purpose and any cost incurred on tests / inspections and stores consumed in the same will be borne by the suppliers. Depot may test / inspect samples before placing of purchase orders.
 - (8) During warranty period (if stores supplied is/ are backed by warranty), if a faults occurs in supplied stores then supplier will be responsible to either rectify the faults

communicated or get the faulty parts replaced within 7 (seven) days of the receipt of information in this regard from the purchaser at his specified places which can be other than the place of delivery of stores. In case supplier fails to rectify the faults or replace the faulty parts in a specified time then purchaser will have the right to take disciplinary action against the supplier and also impose penalty if considered necessary / appropriate.

- (9) During warranty period it will be the responsibility of the supplier to carry out periodic maintenance of supplied stores as prescribed by the manufacturers free of cost as purchasers specified places which can be other than the place of delivery of stores.
- (10) In case of an item has no specifications, drawing or approved sample then a board of officers appointed for the purpose will decide its acceptable standards.
- (11) Make / model / brand and country of origin of stores must be mentioned where applicable.
- (12) Manufacturer certificate of branded items must be provided.
- (13) Prices / rates will be quoted on delivery basis at locations all over Pakistan.
- (14) —Prices / rates will be inclusive of all applicable taxes / duties.
- (15) Prices / rates quoted must be as per accounting unit.
- (16) More than one manufacturer / model may also be quoted giving separate price of each manufacturer / model.
- (17) Prices / rates will be quoted in Pakistani currency.
- (18) Part delivery / part payment will not be accepted / made.
- (19) Payment will be made after acceptance of ordered stores.
- (20) If stores are not delivered within delivery period, penalty will be imposed.
- (21) Items should be packed properly at the time of delivery as per standard packing regime.
- (22) Participation by authorized representatives of concerned firms is mandatory, absence may entail in rejection of bids. In case representative cannot attend the opening proceedings of tender, prior written intimation is mandatory for consideration to accept the bids.
- (23) Technical detail may be sought out by firms.

g. **Commercial Offer.** This offer must include the item wise rate and total amount of stores to be offered. This offered will only be open after acceptance of technical offer.

- (1) **Opening date / time of commercial offer shall be communicated to all participants, whose technical offers have been accepted / qualified on the completion of technical evaluation.**
- (2) As far as possible Price(s) / Rate(s) must be quoted against each item, where prices / rates are not being quoted this should be reflected by words “ NOT QUOTED ”
- (3) List of store(s) (hard copy) will be submitted duly typed, (not hand written) signed and duly stamped on each paper or else offer will be rejected.
- (4) Quoted rates are only valid on firm’s letter head.
- (5) No change should be made in soft copy of tender inquiry provided (list of stores and bidders should fill prices) / rates in front of the items without deleting / amending any column / row and without disturbing the serial numbers.

3. **Additional Documents Requirement.** Firm shall also submit following documents along with technical offer to participate in tender.

- a. Photocopy of registration with Govt agencies / certificate of clearance with services headquarter.
- b. Attested copy of registration certificate issued by Sales Tax Department, copy of NTN certificate.
- c. Attested photocopy of CNIC of MD.
- d. Certificate that firm is neither defaulter nor blacklisted by any Govt Org directly or indirectly.
- e. Undertaking for adequate financial capability to the value of tender.
- f. Attested bank statement for last one year (for firms not yet register with CASD).
- g. **Each bid should accompany 5% of the bid amount of items as earnest money**

(COMPULSORY) in the shape of PAY ORDER / BANK DRAFT in the name of commandant CASD. Tender without earnest money will not be entertained.

h. Detail of works experience with Govt / Semi Govt Org if any (desirable documents but not mandatory).

i. **Tender fee amounting to Rs. 3,000/-** per tender..

4. **Purchasers Right**. Purchasers do not pledge to accept the lowest or any tender and reserves the right of accepting the whole or any part of the offer made. Firm will be given purchase orders after completion of above formalities. **LD charges will be imposed on weekly basis after expiry of delivery period.**

5. **Date and time of receipt of tender**. Tender must reach this depot / dropped in tender box placed at main gate CASD (EME) Rawalpindi by time and date as specified in para a above. This office will not accept any excuse of delay occurring in post. Tender received after appointed / fixed time will not be entertained.

6. **Additional details required for each item separately**









- a. Rate including taxes / duties.
- b. Delivery period of each item.
- c. Offer validity till **30 June 2026**.
- d. Performance guarantee.
- e. Clarify shipping plan (By Air / Sea).
- f. Specify warranty period.

For further details contact.

Phone: 051-5686289 or Visit Web site www.ppra.org.pk

WING REPAIR FACILITY

Ser	Part no	Items	A/U	Tech Specifications	Photo	Remarks
1.	6G/NIV-L-2	Monometer	Nos	<ul style="list-style-type: none"> Brand: Meriam COO: USA Model: 30EBX25 Used for leaking test 		
2.	TTR-5803500-100-5	Pressure Tester	Nos	<ul style="list-style-type: none"> Brand: AMF Kamra COO: Pak Dimension: 4Ft cubic type Used for leaking test 		
3.	2287	Durometer	Nos	<ul style="list-style-type: none"> Brand: Kori Seiki COO: Japan Used for showing the air pressure 		
4.	32C-667	Pressure Hose	Nos	<ul style="list-style-type: none"> Brand: Local COO: Pak Used for passing the air Dimension: 10Ft cubic type 		
5.	LBV34S005XX X	Pneumatic Drill Machine 90 Degree with chuck	Nos	<ul style="list-style-type: none"> Brand: Deceoten COO: USA Used for drilling purpose 		
6.	9061010-060	Pneumatic drill machine pistol grip	Nos	<ul style="list-style-type: none"> Brand: Atlas Copco COO: Swedon Used for drilling purpose 		
7.	PRG-520A	Pop riveter gun	Nos	<ul style="list-style-type: none"> Brand: puma company COO: China Used for drilling purpose 		
8.	PRG-402	Hand pop riveter	Nos	<ul style="list-style-type: none"> Brand: tolsen COO: China Used for drilling purpose 		

Ser	Part no	Items	A/U	Tech Specifications	Photo	Remarks
9.	9063125-0111-54-708	Pneumatic hammer with rivets punches	Nos	<ul style="list-style-type: none"> Brand: tolsen COO: China Used for head Shank riveting purpose Dimension: 12" 		
10.	9043850-025	Rivets shank punch	Nos	<ul style="list-style-type: none"> Brand: Local COO: Pak Used for Shank riveting punch Dimension: 5" 		
11.	21B/NIV-L-53	Wing trestle	Nos	<ul style="list-style-type: none"> Brand: Local COO: Pak Used for wing placing 		
12.	88059	Scraper 2"	Nos	<ul style="list-style-type: none"> Brand: Local COO: Pak Used for cleaning the surface of wing Dimension:2" 		
13.	21C/1038	Digital weight balance	Nos	<ul style="list-style-type: none"> Brand: Local COO: Pak Used for weight the mixing ratio of sealing compound Dimension:5" 		
14.	21C/0032	Vent line nipple blanking	Nos	<ul style="list-style-type: none"> Brand: Local COO: Pak Used for holding the air Dimension:2.5" 		
15.	735930	Torch rechargeable	Nos	<ul style="list-style-type: none"> Brand: Local COO: Pak Used for internal job in wing fuel tank Dimension:10" 		
16.	As per size	Drill bits(2.5, 3.25, 3.66, 4.05, 4.8, 5.6 & 6MM)	Nos	<ul style="list-style-type: none"> Brand: Dormen COO: Brazil Used for drilling purpose Dimension:5" 		
17.	AVN-258520	Pneumatic air pressure(90-100PSI)	Nos	<ul style="list-style-type: none"> Brand: Ingersoll Rand COO: China Model: SS5L5 Used for air pressure Dimension:4Ft 		

Ser	Part no	Items	A/U	Tech Specifications	Photo	Remarks
18.	6127426-009	Solid rivets R/H 3-3	Nos	<ul style="list-style-type: none"> Brand: AMF Kamra COO: Pak Used for securing the fuel tank 		
19.	6127426-010	Solid rivets R/H 3-4 / Solid rivets R/H 3-5	Nos	<ul style="list-style-type: none"> Brand: AMF Kamra COO: Pak Used for securing the fuel tank 		
20.	6127426-018	Solid rivets R/H 4-8	Nos	<ul style="list-style-type: none"> Brand: AMF Kamra COO: Pak Used for securing the fuel tank 		
21.	6127426-037	Solid rivets R/H 6-11	Nos	<ul style="list-style-type: none"> Brand: AMF Kamra COO: Pak Used for securing the fuel tank 		
22.	PR1440A2	Sealing Compound	Kit/ Nos/ Tube	Brand: PPG PR-1440 A-2 AMS-S-8802D Type 2 Class A-2 Spec Fuel Tank Sealant Pint Kit		
23.	PR1422A2	Sealing compound	Tube	<ul style="list-style-type: none"> Brand: PPG COO: USA Used for prevent the external fuel leakage in wing top gasket 		
24.	0454993-000 MIL-G-6032D	Grease Special Aircraft	Nos	<ul style="list-style-type: none"> Brand: Aero Shell COO: USA Used for air leaking test 		
25.	40R/AMF-3	Empty container (Bowl)	Nos	<ul style="list-style-type: none"> Brand: Local COO: Pak Used for mixing the compound 		



SMK TOOLS

Ser	Part no	Items	A/U	Tech Specifications	Photo	Remarks
1.	M81969/14-04	Installation & removal Tool	Nos	DANIECS USA		
2.	M81969/1-02	Insert/Extract tool	Nos	DANIECS USA		
3.	AVN-6810299	Pin Extractor	kit	DANIECS USA		
4.	M81969-1-04	Installation & removal Tool	Nos	ASTRO TOOL		
5.	50-80590	Pin Removal tool	Nos	WAY TEC WIRE		
6.	WL-14944	Micro Cutter	Nos	WAY TEC WIRE		
7.	JTH6E09VE	Hex Key 9/64	Nos	BEETA		
8.	GIT-517C1	Crimp Tool (Twermonal End)	Nos	HUAWEL		
9.	TL5053	Universal wire Striper 20-26	Nos	WILTRONICS		
10.	728380	Crimp Tool	Nos	WILTRONICS		

Ser	Part no	Items	A/U	Tech Specifications	Photo	Remarks
11.	M81969/14-01	Pin Inserter	Nos	WILTRONICS		
12.	M22520/2-01	AFM8 Crimp tool	Nos	WILTRONICS		
13.	51200136196 42	Positioner K280	Nos	DAWIECS USA		
14.	51200136196 56	PositionerK50 3	Nos	DANIECS USA		
15.	TSK8000	Adjustable Twist Strip tool	Nos	DANIECS USA		
16.	DAK123-22A	Inserter, electrical contact / IDU Pin Insert tool	Nos	DANIECS USA		
17.	M22520/2-01	Positioner K13-1	Nos	DANIECS USA		
18.	M22520/2-07	Contact positioner, Ter minal crimping tool,k40	Nos	DANIECS USA		
19.	M22520/2-06	Contact positioner, Ter minal crimping tool,k41	Nos	DANIECS USA		
20.	M22520/2-09	Positioner K42 Contact positioner, Ter minal crimping tool,k42	Nos	DANIECS USA		
21.	M22520/2-11	Positioner K287 Contact positioner, Ter minal crimping tool,k41	Nos	DANIECS USA		

Ser	Part no	Items	A/U	Tech Specifications	Photo	Remarks
22.	M22520/2-01	AFM8 Crimp Tool / Positioner K330-3	Nos	DANIECS USA		
23.	M22520/2-10	Contact positioner, Terminal crimping tool, k48	Nos	DANIECS USA		
24.	M22520/2-37	Contact positioner, Terminal crimping tool, k709	Nos	DANIECS USA		
25.	M22520/2-01	AFM8 Crimp Tool / Universal Positioner Die	Nos	DANIECS USA		
26.	M22520/5-01	Pliers / HX4 Crimp Tool	Nos	DANIECS USA		
27.	DRK-378	Pin Extract Tool	Nos	DANIECS USA		
28.	PRK-378	IDU Pin Insert tool	Nos	DANIECS USA		
29.	GMT-232 / M22520/37-01	Crimp Tool / Environmental Splice Crimper	Nos	DANIECS USA		
30.	TH1A (M225201/1-02)	Turret Head / Positioner TH1A	Nos	DANIAL USA		
31.	M225201/1-04	Contact positioner, TH 163	Nos	DANIAL USA		
32.	BRK-378	Molex Pin Extractor	Nos	DANIAL USA		

Ser	Part no	Items	A/U	Tech Specifications	Photo	Remarks
33.	5120-288-7839	Screw Dvr Set Jewelers	Nos	STANILEY JEWELRS		
34.	DRK-378	Insert/Extract tool	Nos	DANIAL USA		
35.	DRK-378	Insert/Extract tool	Nos	DANIAL USA		
36.	DRK-378	Insert/Extract tool	Nos	DANIAL USA		
37.	DCT4-102	Crimp Tool (Terminal End	Nos	DANIAL USA		
38.	45-121	Universal Wire Stripper Tool 20-26	Nos	DANIAL USA		
39.	728380	Crimp Tool	Nos	DANIAL USA		
40.	M22520/37-01 GMT-232	Crimp tool / Environmental Splice Crimper	Nos	DANIAL USA		
41.	459-91-100SB-1	Engine lifting Sling	Nos	EMSAAERO		
42.	NIV-680	Engine Stand	Ea	LYCOMING		

Ser	Part no	Items	A/U	Tech Specifications	Photo	Remarks
43.	AVN-NIV-C-211	Compression Gauge	Nos	BOSCH		
44.	5807090-000	Maintenance Platform	Nos	DANIECS USA		
45.	6783304400	Compass, standby	Nos	LOCAL		
46.	5942015-100	Trestle	Nos	LOCAL		
47.	6001098-100	Trestle Front	Nos	LOCAL		
48.	TA55270000C	Elevator Template	Nos	UNK		
49.	330A98-3310-00	Mounting Tool Nose gear	Nos	BOEING		
50.	6001901-100	ECS Servicing Unit	Nos	DANIECS USA		
51.	5807034-000	Tail Support	Nos	LOCAL		
52.	AVN-GSE-48	Spark Plug Gap Adjustment Tool	Nos	STANILY		



Ser	Part no	Items	A/U	Tech Specifications	Photo	Remarks
53.	5107052-000979	Prop Cover	Nos	LOCAL		

MISC EXPANDABLES

Ser	Part No	Nomen	A/U	Tech Specifications	Photo
1.	GAC115P1	Lubricant	Kit	Brand: Molykote 111 COO: USA/ Europe Packing 5 oz tube	
2.	AP-300	Aircraft Metal Polish Medium / Rolite Company	Kit	Brand: Rolite Company COO: USA/ Europe	
3.	Nushine II-G6 (Quick Cut)	Nushine II-G6 (Quick Cut) / Nuvite Chemical Compounds Corporation	Kit	Brand: Nuvite Chemical Compounds Corporation COO: USA/ Europe	
4.	Nushine II-F7 (Heavy Cut)	Nushine II-F7 (Heavy Cut) / Nuvite Chemical Compounds Corporation	Kit	Brand: Nuvite Chemical Compounds Corporation COO: USA/ Europe	
5.	Nushine II-F9 (damage Surface)	Nushine II-F9 (damage Surface) / Nuvite Chemical Compounds Corporation	Kit	Brand: Nuvite Chemical Compounds Corporation COO: USA/ Europe	
6.	Nushine II-C (Oxidation remover)	Nushine II-C (Oxidation remover) / Nuvite Chemical Compounds Corporation	Kit	Brand: Nuvite Chemical Compounds Corporation COO: USA/ Europe	

Ser	Part No	Nomen	A/U	Tech Specifications	Photo
7.	Nushine II-S (Final Finish)	Nushine II-S (Final Finish) / Nuvite Chemical Compounds Corporation	Kit	Brand: Nuvite Chemical Compounds Corporation COO: USA/ Europe	
8.	Perfect-It III (#05936)	Perfect-It III (#05936) / Extra Cut Rubbing Compound (3M Corporation)	Kit	Brand: 3M COO: USA/ Europe Perfect-It III Extra Cut Rubbing Compound (3M Corporation)	
9.	Skyde Clear FC3000 / PC3000	Skyde Clear PC3000 / Nuvite Protective Clear Coat	Kit	Brand: Nuvite Chemical Compounds Corporation COO: USA/ Europe	
10.	AMS-1530	Aircraft Cleaner X-400	Gal	Brand: Zip Chem COO: USA X-400 – AMS 1530-009646	
11.	Standard	Cotton/ Wool Rotary Pad	Ea	Rupes Wool Polishing Pads For Rotary - 9.BL180H 180 MM	
12.	Detergent	Arm and Hammer Plus OxiClean	Gal	Brand: Arm and Hammer Plus OxiClean	
13.	Nuvite EQ145	Flannel Sheets	Ea	Nuvite EQ145 Nushine Flannel Polishing cloth	



Ser	Part No	Nomen	A/U	Tech Specifications	Photo
14.	100% Isopropyl Alcohol or Granitize Pt no XG-5	Granitize Pt no XG-5 / Aviation Hard Surface Cleaner concentrate	Gal	Brand: Granitize Aviation COO: Europe	
15.	Xzilon 3 Granitize Pt no X-3500	Granitize Aviation International / Xzilon 3 / X-3500-18	Kit	Brand: Granitize Aviation COO: Europe	
16.	MCS352	Lubricant	Kit	Brand: TBM COO: USA	
17.	MIL-PRF-6085	Lubricant	Gal	Brand: Aeroshell COO: USA/ Europe Aeroshell Fluid 12	
18.	ROYCO 885	Lubricant	Gal	Brand: Royco COO: USA/ Europe ROYCO 885	
19.	Dinitrol AV30 (GAC115AD)	Corrosion Inhibiting Compound Type-VII	Kit	Brand: Chemetall COO: USA/ Europe/ Singapore ARDROX AV30	

Ser	Part No	Nomen	A/U	Tech Specifications	Photo
20.	MS20995CY20	Safety Wire	Nos	Brand: Malin COO: USA Military Standard MS20995CY20 Copper 0.020 Diameter Breakaway Wire	
21.	PRO SEAL 870 CL B TYPE-2	SEALANT TYPE X	Nos	Brand: PPG Aerospace COO: USA	
22.	A-A-59107	Toulene	Gal	COO: USA	

MASTER CALIBRATORS

Ser	Part no	Items	A/U	Tech Specifications	Photo
1.	516-946-26	GAGE, BLOCK SET, 0.5 ? 100 MM, 87 PIECES, OEM REF NO 516-946, MITUTOYO CORP, JAPAN, NSN BY AUSTRALIA	Nos	1 x mm Gauge Block Set (0.5 to 100 mm) OEM: MITUTOYO, JAPAN Grade: 0 Material: Steel Millimeter Gauge Block Set, 0.5 to 100 mm -87 pieces	
2.	516-902-26	GAGE, BLOCK SET, 0.5 ? 4 INCH, 81 PIECES, OEM REF NO 516-902-26, MITUTOYO CORP, JAPAN, NSN BY CANADA	Nos	1 x inch Gauge Block Set (0.05 to 4 inch) OEM: MITUTOYO JAPAN Grade: 0 Material: Steel Inch Gauge Block Set, 0.05 to 4 inch -81 pieces	
3.	629901-32	KNOB ASSEMBLY,COUR SE,OEM REF NO 629901-32, FLIGHT INSTRUMENT, RW, PUMA,FRANCE	Nos	Required for MFD-255FF PUMA SM Imported Item Required Reference available at www.digikey.com/en/products/detail/grayhill-inc/62a11-02-020s/268797	

CAP BLDG ITEMS

Ser	Part no	Items	A/U	Tech Specifications	Photo	Remarks
1.	5900754-100	Sunblind Shed	Nos	Height 12 ft , Width 6 ft, Length 8 ft Req for parking ac/hel in summer season to avoid fuel vaporization and protect the life of instrument and rubber items Material: Aluminum		
2.	5807033-000	JACK	Nos	Req for jacking up of Msk aircraft for maint of main ldg leg, removal / instl of main wheel. Loading Cap 2 Ton		
3.	413-00002-001	Emergency Backup Battery	Nos	Emergency Backup Battery is internal part of ASPEN 1000H and no said item is aval in Tech Store		Book reference attached at Appx 1 to Anx D
4.	M2922	Cone and Rollers	Nos			

2.6.5 Outline Drawing

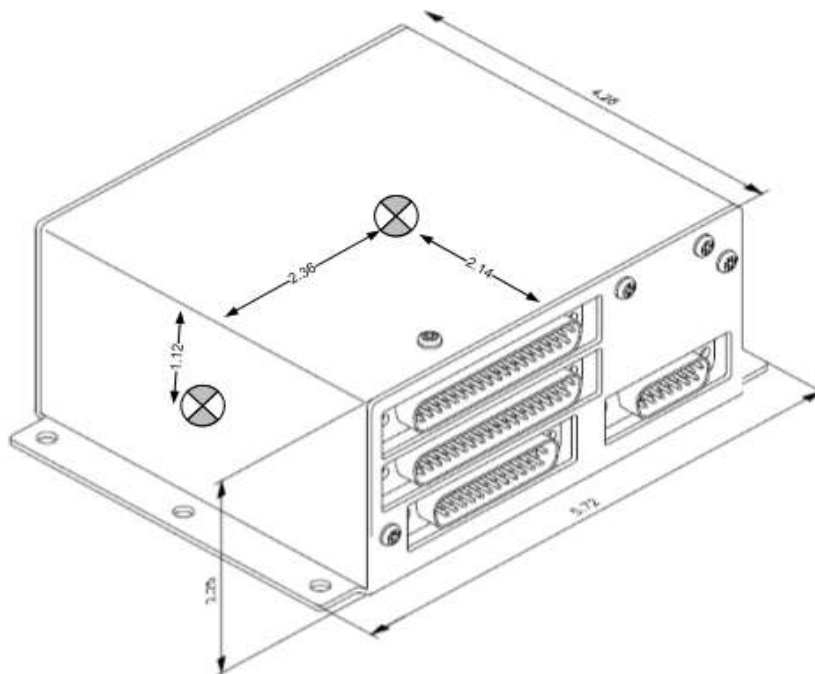

Figure 2-6 - ACU2 Outline Drawing (inches)

2.7 EBB58 Emergency Backup Battery

The EBB58 can only be installed with an EFD1000 MFD P/N 910-00001-105.

2.7.1 General Specifications

Part Number	413-00002-001
Width	3.6 in. (widest point on mounting clips)
Height	1.7 in.
Length	8.52 in. (rear of mounting tray to connector)
Weight	2.25 lbs. (includes bracket)

2.7.2 Operating Specifications

Operating Temp:	-20°C to +55°C
Storage Temp:	-55°C to +85°C
Max Operating Altitude.....	35,000 ft. Unpressurized/ 55,000 ft. Pressurized
Cooling	None required
Max Humidity	95% at 50°C
Input Voltage	Powered by EFD1000
Nominal Current.....	Powered by EFD1000

2.7.3 I/O Specifications

Proprietary

2.7.4 Certification Specifications:

The EBB58 is certified as a component of the EFD1000 system

Software: None

Complex Electronic Hardware (CEH): None

Environmental:

RTCA DO-160E..... Contained within the EFD1000 Environmental
 Qualification Form. See Section 13

2.7.5 Outline Drawing

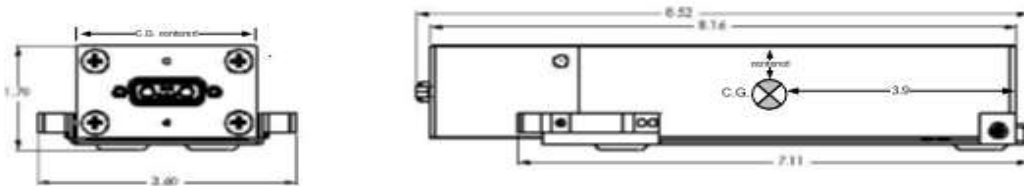

Figure 2-7 – EBB58 Emergency Backup Battery Drawing (inches)